



**COUNCIL OF EUROPE
EUROPEAN CENTRE ON PREVENTION
AND FORECASTING OF
EARTHQUAKES (E.C.P.F.E.)**



**EARTHQUAKE PLANNING AND
PROTECTION ORGANIZATION
(E.P.P.O.)**

**TEAM FOR DEVELOPMENT OF CODE OF INTERVENTIONS ON REINFORCED CONCRETE BUILDINGS
HARMONIZATION TEAM OF CODE OF INTERVENTIONS TO EUROCODES**

**CODE OF INTERVENTIONS (KAN.EPE.)
FINAL HARMONIZED TEXT**

APRIL 2013

PREAMBLE

1. The significant need for a normative text for the Design of structural interventions had been long recognized: in a relatively new sector of science and technology, the methods of design are not yet settled – therefore the Designer undertakes a disproportionately big responsibility when adopting a specific design logic or a specific calculation method or, even, a specific technique of repair and strengthening. But also the economy and safety of structures is not always catered for properly. Therefore, we have the well-founded hope that the present 5th (and final) Text of the Code of Interventions on existing buildings will be particularly useful for Engineers and for society in general.
2. On the other hand, the very same reasons that necessitate the introduction of such a Code, also make its compilation more difficult; precisely because of the recent growth of the particular scientific and technical sector, the relevant research has not, on all occasions, been completed, or (more often) adequate international consensus has not yet been reached on the relevant problems. Therefore, the choice of methods and the harmonization of the approach to matters that were followed in this Code are subject to criticism. Besides, it is not a coincidence that among National Codes, no relevant texts are readily available in international literature on such matters. The introduction of the first edition of EC8 in 1994 paved the way, going even further with the final text of EC8 in 2004 and 2005. But even the relevant part of EC8 does not offer the thoroughness that daily practical applications require. FEMA's far more well-wrought normative texts (USA) cover mainly general principles and analysis only. In the framework of this reality, the present Text of the Greek Code of Interventions that is introduced attempts to cover an even wider spectrum of needs of engineering practice.
3. The 1st Draft of this Code had been submitted for peer review to a 23-member Committee of Consultants, consisting of the following distinguished Greek Engineers (March 2004): I. Avramidis, S. Anagnostopoulos, K. Anastasiadis, M. Argirou, O. Vaggelatos, I. Vagias, H. Vafeiadis, T. Dragiotis, I. Ermopoulos, A. Kanellopoulos, A. Karabinis, P. Karydis, B. Koliass, B. Koumoussis, B. Markykostas, E. Mystakidis, S. Pantazopoulou, M. Papadrakakis, G. Penelis, I. Tegos, A. Triantafyllou, F. Tsirlis and N. Chroneas. Additionally to oral comments, the Authoring Committee also received comments in writing from Consultants I. Avramidis, K. Anastasiadis, M. Argirou, I. Vagias, H. Vafeiadis, I. Ermopoulos, A. Kanellopoulos, B. Markykostas, I. Tegos, A. Triantafyllou and N. Chroneas. All comments and remarks were taken into consideration, and were answered in writing to each Consultant.
4. The 2nd Draft of the Code was drawn up taking into consideration the aforementioned comments and remarks, as well as developments in international literature and research financed by OASP in the meantime. This 2nd Draft was checked once more (June 2006 to July 2007) by the following 9 esteemed Structural Design Offices: Vadaloykas & Son, DOMOS, DENCO, OMETE, OTM-Temnousa, Penelis G., Tsirlis F., Pagonis-Chroneas-Kinatos, Papathanasiou A. as well as ITSAK Researchers. These Offices volunteered to carry out their studies aiming to investigate the general applicability of the Draft of the Code. The studies involved specific examples of buildings prepared by the Authoring Committee.

5. The 3rd final Draft of the Code was drawn up taking into consideration the conclusions and comments that resulted from the aforementioned studies, and after problems were solved and corresponding answers were given. This Draft, before its final configuration as a National Standard, was put to public consultation until the end of 2009.
6. The final (4th) version of the National Standard (September 2010) was drawn up taking into consideration the conclusions that resulted from the public consultation as well as the most recent remarks and observations of the Members of the Authoring Committee, while the present harmonised final Text (5th) resulted after the necessary interventions so that the 4th text is compliant with the Eurocodes system.
7. A final observation concerns the search of an optimal synthesis between the adversative requirements which we usually have from a Code; it needs to be complete, scientifically collegiate, safe, economic, and legally consistent – but is also needs to be as simple as possible and promptly applicable. In the past few years, significant progress has been made in our Country towards this direction – as opposed to the previous generation of Codes.

More specifically, for the subject of the present Code there are at least two reasons which lead to an (inevitable) additional “complexity”:

- a) Here, we do not deal with a new structure to which, through our Design, we lend the desirable attributes (as dictated by modern science and engineering practice), but rather with an existing structure, the various behaviors of which should first be comprehended, and subsequently modified. That is to say, double the difficulty.
- b) In the field of interventions, apart from the behaviour of additional materials and elements that will be used, we also must study the intended behaviour of interfaces between existing and new materials or elements. Again, double work.

If indeed it is taken into account that the relevant scientific knowledge has not yet been completely incorporated in the curriculum of our academic Faculties, the Code of structural interventions also undertakes an additional role of a more analytical presentation of the subject. The sum of all the above hindrances could easily create the impression of “unnecessary” complexity. However, the nature of the subject does not allow further simplification of the Code, without the danger of it degrading to a recipe-like approach. The Authoring Committee has drawn up relevant justification notes and literature references for the major Chapters of the Code.

Athens, September 2010

THE AUTHORING COMMITTEE

T. P. Tassios
(Scientific director)

C. Kostikas
(Coordinator)

Team of Authors:

Abakoumkin V., Vintzilaiou E., Vlachos I., Vougioukas E., Dritsos S., Theodorakis S.,
Kappos A., Plainis P., Spanos C., Stylianidis K., Fardis M., Chronopoulos M.

Members: Gazetas G., Kremezis P., Spyrakos K.

Athens, February 2011

THE HARMONIZATION TEAM

Coordinator : T. P. Tassios

Members: Dritsos S., Kappos A., Fardis M., Chronopoulos M.

SYMBOLS**LATIN UPPER CASE LETTERS**

Chapter

A_b	area of lapped rebars		8
A_c	area of concrete section	7	
$A_{c\delta}$	interface area		8
A_j	sectional area of confinement reinforcement in the form of collars	8	
A_j	sectional area of the required external shear reinforcement	8	
$A_{j\delta}$	sectional area of steel members (cross-collars) in each diagonal direction	8	
A_{jh}	area of horizontal jacket reinforcement	8	
A_{jv}	area of vertical jacket reinforcement		8
A_s	sectional area of longitudinal reinforcing rebars	6,7	
A_{sb}	sectional area of supporting reinforcement	8	
$A_{s\delta}$	area of shear reinforcement	8	
A_{sh}	total area of horizontal hoop legs	7	
A_{so}	sectional area of tension reinforcement in the initial member	8	
A_{sw}	cross sectional area of shear reinforcement	8	
B	distribution width of compressive force	8	
C_0	coefficient correlating spectral displacement to displacement at the building top	5	
C_1	inelastic over elastic displacement ratio	5	
C_2	coefficient accounting for the effect of the hysteretic loop shape on maximum displacement		5
C_3	coefficient accounting for displacement increase due to second order effects	5	
C_m	coefficient of active mass	5	
C_t	coefficient for the empirical assessment of the fundamental period	5	
D	section diameter	8	
EA_p	axial stiffness along the diagonal ($A_p=t \cdot b$)		7
E	modulus of elasticity (in general)	4,7	
E_c	modulus of elasticity of concrete	7	
E_j	modulus of elasticity of fiber reinforcement polymer (confinement material)	6,8	
E_{FRP}	modulus of elasticity of composite materials	6	
E_s	modulus of elasticity of steel		6,8
F	effect of action (force, in general)	4,7,9	
F_{cm}	jacket compression force	8	

BODY

F_i	seismic force at storey i	5	
F_j	utilized axial force of confinement material		
$F_{j\delta}$	diagonal tensile force at the joint	8	
F_{px}	total inertial diaphragmatic force at level x	5	
F_{res}	residual strength	4,7	
F_{sd}	applied shear force		6
Chapter			
F_{ud}	design force of interface shear resistance (due to dowel action, friction, total respectively)		6
F_y	yield strength (ultimate strength= F_u)		4,7
GA_ϕ	bay shear stiffness ($A_\phi=t \cdot l$)		7
H_{tot}	total height of structure	7	
H_{op}	storey height		7
I_c	moment of inertia of uncracked section	7	
K	elastic stiffness (F_y/δ_y)	7	
K_e	equivalent lateral stiffness	5	
K_o	elastic lateral stiffness		5
K_y	lateral stiffness of foundation		
K_ϕ	rotational stiffness of foundation	7	
L	length along the diagonal	7	
L_{av}	available anchorage length of the strengthening reinforcement?	8	
L_b	theoretical beam length	7	
L_{bn}	net beam length	7	
L_e	effective anchorage length		8
L_{pl}	plastic hinge length		5
L_s	shear length		7
M	bending moment	4,9	
M_{Ed}	bending moment at the bottom section of the member derived from analysis	9	
M_{EW}	bending moment at the vase of a shear wall derived from analysis	9	
M_{id}	bending moment at edge i of a member for the capacity design against shear force	9	
M_{Rb}	bending resistance of beam		7,9
M_{Rbi}	bending resistance of a beam at its edge i	9	

BODY

M_{Rc}	bending resistance of a column		7,9	
$M_{Rc,i}$	bending resistance of a column at its edge i		9	
M_{Rd}	bending resistance			9
M_{Rd}	bending resistance at the bottom section of a member	9		
M_{RW}	bending resistance at the base of a shear wall		9	
M_u	ultimate bending moment		7	
M_{vu}	moment at shear failure		7	
M_y	yield moment			7
M_{yb}	beam yield moment			7
M_{yc}	column yield moment			7
N	axial force			4,7
N_{bd}	maximum tensile stress of an anchor for bond slip between the anchor and the connecting material			6
N_{cd}	maximum tensile force of an anchor for anchor and glue pull-out from the surrounding concrete			6
N_E	seismic axial force of the jacket		8	
N_M	compressive jacket force due to bending moment after the intervention	8		
N_{ud}	design value of anchor resistance against axial force		6	
N_{sd}	design value of axial force		6	
				Chapter
N_v	jacket axial force due to additional axial loading		8	
N_{yd}	tensile yield stress of anchorage		6	
R	resistance (in general)			
R_d	(design and reassessment) resistance value		4,9	
R_k	representative value of material properties that are inherent in resistance and are defined for a given probability of exceedance		4	
R_{id}	resistance of a connection at the interface		8	
R_m	available resistance of a member		5	
S (or E)	action (in general), or action effect due to seismic load combination			4,5
S_d	design and reassessment value		4,9	
S_E	action effect from (elastic) analysis		5,9	
S_{Fd}	design value of any action effect for checking soil and foundation		9	
$S_{F,E}$	design force of an action effect for checking soil and foundation against seismic Actions, from the analysis			9

BODY

$S_{F,G}$	design force of an action effect for checking soil and foundation against gravity loads prescribed in seismic load combinations, from the analysis	9	
S_{id}	force acting on the interface		8
S_{κ}	representative action value	4	
S_y	section modulus of the added part with the neutral axis through the centroid	8	
T	fundamental period of a building		4,5,7
T_0	fundamental period of a (fixed-base) building		5
T_e	equivalent fundamental period		5
T_B, T_C	characteristic (corner) spectral periods		7
T_m	recurrence period of an earthquake		5
\tilde{T}	effective (equivalent) fundamental period (due to soil-structure interaction)	5	
V	base shear or shear		4,5
V_u	base shear at the ultimate condition	4	
V_1	base shear at first yield	4	
V_{cd}	contribution of concrete to shear resistance	8	
V_E	shear force in a wall from the analysis	9	
V_{el}	elastic shear demand		
$V_{g+\psi 2q,b}$	beam shear force at both sides of a joint due to gravity loading		7
V_{jd}	contribution of new shear reinforcement to shear resistance	8	
V_{jh}	horizontal shear force at a joint		7,8
V_{jv}	vertical shear force at a joint		7,8
V_{Mu}	shear force at bending failure		7
V_R	ultimate shear of a member		4,7
V_{R1}	shear causing inclined member cracking	7	
V_{Rdr}	residual shear resistance of the initial structural member	8	
V_{Rd1}	shear resistance of members without shear reinforcement	5	

Chapter

V_{Rd2}	design value of shear resistance due to inclined compression	8	
V_{Rd3}	design value of shear resistance due to inclined tension		8
$V_{Rd,int}$	shear resistance of a reinforced interface		6
V_{RM}	shear resistance V_{Rd2} of the additional layers or the jacket		8
V_{Rmax}	limit value of shear resistance corresponding to web failure due to inclined		

BODY

	compression		7
V_{Sd}	acting shear force		4,5,6
V_{Sd}	design shear force		6,8,9
$V_{Sd,tip}$	design shear force at the tip of the strengthening reinforcement	8	
V_{Sdj}	contribution of the additional external reinforcement to the shear resistance	8	
V_{top}	normalized axial force of an overlying column		7
V_u	ultimate shear		7
V_w	contribution of transverse reinforcement to the shear resistance		7
V_{wd}	contribution of the shear reinforcement of the initial member to shear resistance	8	
V_y	building yield shear force		5
W	weight corresponding to the total vibrating mass of the structure		5

LATIN LOWER CASE LETTERS

a_{sw}	distance between hoops		8
a_v	coefficient equal to 1 in case inclined cracking preceding bending-induced yield	7	
b	section width (at the interface) or (width of compression zone) or width of a masonry infills diagonal		4,7,8
b_0	width of confined core		8
b_c	width of concrete section		7
b_c	width of section core		
b_i	distance between longitudinal rebars restrained by hoops or hooks		7
b_j	joint width		7
b_j	width of plate or fabric or strengthening material		6,8
b_w	width of structural member flange under tension to which the strengthening material is affixed		7, 8
c	rebar coverage		7, 8
d	effective depth of member section or dislocations or displacements (in general) or as a subscript denoting design value		4,7,8,9
d_b	rebar diameter		6
d_b	diameter of longitudinal rebars under tension		7
d_h	diameter of transverse reinforcement rebar		8
d_j	effective depth of section		8
d_s	diameter of reinforcing rebar		8
f_{bc}	mean value of compression strength of blocks		7
f_{bk}	characteristic bond strength between an anchor and the connecting material	6	

BODY

f_c	compressive strength of concrete		
$f_{ct,m}$	mean value of axial tensile strength of concrete	8	
$f_{c,old}$	compressive strength of existing concrete	6,7	
			Chapter
$f_{c,new}$	compressive strength of new concrete	6	
f_{cd}	design value of concrete compressive strength	6	
$f_{cd,c}$	design value of confined concrete compressive strength	8	
f_{ck}	characteristic compressive strength of concrete	6	
f_{ct}	tensile strength of concrete		6,7
f_j	tensile strength of FRP	6	
f_j'	reduced value of FRP tensile strength	6	
f_{jk}	characteristic value of retrofitting material strength	8	
f_{mc}	mean value of mortar compressive strength	7	
f_{sy}	yield strength of reinforcing steel	8	
f_{yd}	design value of steel yield strength (of a rebar, plate or anchor)	6	
f_{yk}	characteristic value of yield strength		6
f_y	rebar yield strength		7
f_{yw}	yield strength of transverse reinforcement		7,8
f_{ydo}	yield strength of tension reinforcement of the initial member	8	
f_{ywd}	design value of yield strength of transverse reinforcement		8
f_{wc}	compressive strength of masonry		7
$\bar{f}_{wc,s}$	mean value of masonry compressive strength along the diagonal direction		7
$f_{wc,k}$	characteristic value of masonry compressive strength along the vertical direction	7	
\bar{f}_{wv}	mean value of masonry shear strength		7
h	height of initial member or height of section		5,7,8
h_b	beam height		7
h_c	height of section core		5,7
h_c	height of column section		7
h_δ	length of joint diagonal		8
h_{ef}	effective building height		5
h_j	height of strengthening member		8
$h_{j,ef}$	effective height of strengthening contributing to shear resistance		8
h_n	building height (in meters)		5
h_m	building height (in meters)		5
h_s	distance between the existing and new transverse reinforcement of the member	8	

BODY

h_{st}	storey height		7
$h_{st,n}$	net storey height	7	
k	number of FRP layers or monolithic coefficient	6,8	
k_0	fixed-base building stiffness		5
$k_{\theta y}$	monolithic coefficient for θ_y		8
$k_{\theta u}$	monolithic coefficient for θ_u		8
k_{κ}	monolithic coefficient for stiffness	8	
k_r	monolithic coefficient for strength	8	
k_x	foundation lateral stiffness	5	
k_x	lateral stiffness	5	
k_v	coefficient of deformation distribution along the critical inclined crack	8	
k_{ϕ}	foundation rocking stiffness		5
			Chapter
l	available rebar anchorage length	6	
l_b	required rebar anchorage length	6	
l_b	rebar lap splice length		7
$l_{b,min}$	minimum rebar lap splice length for the development of ultimate bending moment	7	
$l_{bu,min}$	minimum rebar lap splice length for the development of ultimate chord rotation	7	
l_e	length of bond with concrete at the plate tips	6	
l_e	anchor embedment length	6	
l_s	available reinforcing bar lap splice length	8	
l_{so}	required reinforcing bar lap splice length	8	
l_o	distance between points of contraflexure along the member length	8	
m	local behavior factor (of individual structural members), or member ductility factor	2,4,5,7,8,9	
m_i	mass concentrated at level i		5
n	number of cores (specimens), or number of principal members at a given level or number of cycles, or reduction factor of the uniaxial compressive strength	3,6,7	
n_b	total number of supporting reinforcement	8	
n_D	total number of dowels	8	
n_{rest}	number of longitudinal lapped rebars restrained by a hoop or hook	7	
n_{tot}	total number of longitudinal lapped rebars	7	
p_e	probability of exceedance	4	
p_f	probability of failure		4

BODY

q	global behavior factor ($q=q_v \cdot q_\pi$ or $q_o \cdot q_d$)		2,4,5,7,9
q'	value of q for performance level B		4
q*	modified value of q		4
q _v	behavior factor component due to structural overstrength		4,8
q _π	behavior factor component due to structural ductility	4,8	
r	bend radius of FRP at the corners of the member		
r _i	relative damage index		8
r _K	reduction factor of K		7
r _R	reduction factor of F _y		7
r _{δ_u}	reduction factor of δ _u		7
1/r	curvature (φ)		4,7
(1/r) _{cu}	ultimate curvature of concrete under compression, φ _{cu}		7
(1/r) _{su}	ultimate curvature due to fracture of the tension reinforcement φ _{su}		7
(1/r) _u	ultimate curvature, φ _u		7,9
(1/r) _y	yield curvature, φ _y		7,9
s	second (sec), or distance between successive hoops, or distance between successive collars or strips, or imposed monotonic or cyclic sliding, or local deviation, or relative sliding		3,5,7,8
Chapter			
s _d	tolerable sliding value		6
s _f	relative sliding		6
s _{fu}	relative sliding at the interface corresponding to maximum friction resistance	6	
s _h	distance between hoops		7
s _j	axial distance between the external reinforcement in case of strips		8
s _u	sliding corresponding to the maximum utilized shear resistance		6
t	jacket thickness		6
t _{eff}	wall thickness		7
t _{pl.}	plate (leaf) thickness		8
t _j	width of strengthening material		6,8
t _j	FRP width		8

BODY

t_j	width of collar section in the jacket	8	
t_{j1}	width of a single FRP layer		8
t_{jh}	width of fabric with fibers parallel to the beam axis	8	
t_{jv}	width of fabric with fibers perpendicular to the beam axis	8	
u_o	length of jacket transition	8	
w_d	tolerable value of crack opening	6	
w_j	width of collar section or of external reinforcement in case of strips	8	
\bar{x}	height of compression zone		7
\bar{X}	average value		3
z	lever arm of internal forces		7
z_b	lever arm of beam internal forces	7	
z_c	lever arm of column internal forces	7	

GREEK UPPER CASE LETTERS

A_i	performance level for Immediate Occupancy (IO)	2,4	
B_i	performance level for Life Safety (LS)	2,4	
Γ_i	performance level for Collapse Prevention (CP)	2,4	
Δ_{ϵ_s}	increase in the normalized deformation of reinforcement		
ΔM_{do}	additional design bending moment required to contribute in the strengthened section		8
K_E	coefficient		7
Φ_e	spectral acceleration corresponding to the equivalent fundamental period of a building	5	
Ω	minimum value of ratio M_{Rd} / M_{Ed}	9	
\emptyset	hole diameter in which the anchor is embedded	6	

GREEK LOWER CASE LETTERS

α	confinement effectiveness factor, or coefficient (in general), angle between (external) transverse reinforcement and axis of a member, or hardening ratio, or diagonal inclination, or length of member subjected to bending moments of equal sign	4,5,6,7,8	
α_s	moment-shear ratio ($M/V \cdot h$)	7	
α_v	coefficient dependent on the value of V_{R1}		Chapter

BODY

β	coefficient of length increase, coefficient (in general), or correction factor		4,5,7,8,9
β_D	coefficient of dowel mechanism contribution	6	
β_F	coefficient of friction mechanism contribution	6	
β_L	coefficient of available anchorage length	8	
β_w	coefficient of influence of the width of strengthening reinforcement	8	
γ	angular deformation		4,7
γ_1	importance factor		4
γ_b	partial factor for bond		6
$\gamma_{c,}$	partial factor for concrete	4,6	
γ_c	partial safety factor of concrete under tension	6	
γ_f	partial factor for actions	4	
γ_g	partial factor for permanent actions	4	
γ_{inst}	partial safety factor dependent on the quality of on-site anchor application	6	
$\gamma_{I\Omega II}$	partial safety factor dependent on the type of FRP fibers	6	
γ_m	partial factor for material property	4	
γ_q	partial safety factor for variable actions	4	
γ_{Rd}	partial safety factor for resistance (FE models)	4,6,8,9	
γ_s	partial safety factor for steel		4
γ_{Sd}	partial safety factor for actions (FE models)	2,4,5,7,9	
γ_u	angular deformation of an infill panel at failure	9	
γ_y	angular deformation of an infill panel at yield	9	
δ	deformation, or sliding of rebar under tension relative to concrete, or displacement, or angle of the member diagonal to its axis, or acceptable value of the relative rebar sliding		6,7,8,9
δ_{avg}	average displacement		
δ_{max}	maximum displacement	8	
δ_d	design deformation at failure		5,9
δ_{el}	maximum elastic building displacement	7	
δ_{inel}	maximum inelastic displacement of a building	7	
δ_t	target displacement		5,9
δ_u	ultimate deformation (or displacement), or sliding amplitude at which the maximum friction resistance is utilized at the interface		5,7,8,9
$\delta_{u,pl}$	plastic deformation capacity		7
δ_y	yield deformation	7	

BODY

ε	strain		9
ε_c	compressive strain in the concrete	6	
ε_{cu}	ultimate compressive strain in the concrete	7	
$\varepsilon_{c2,c}$	strain corresponding to the compressive strength of the confined concrete	6	
$\varepsilon_{cu,c}$	ultimate compressive strain in the confined concrete	6	
			Chapter
$\varepsilon_{cu,c}$	maximum compressive strain in the confined concrete	8	
ε_j	strain in the strengthening material	8	
ε_{jd}	design strain of the confinement members	8	
$\varepsilon_{j,crit}$	critical value of strain in the strengthening material	8	
ε_{ju}	maximum tensile strain in the material	8	
ε_s	maximum strain in the steel		6
$\varepsilon_{sy,d}$	design yield strain of longitudinal rebars	8	
ε_{su}	ultimate steel strain		6
ε_{su}	uniform ultimate strain of the tension reinforcement	7	
ε_y	yield strain		
ε_{yd}	design yield strain in the steel		6
ζ	damping ratio of a building		5
ζ_0	damping ratio of a fixed-base building	5	
ζ_θ	damping ratio the foundation		5
$\tilde{\zeta}$	effective (equivalent) of the soil-structure system	5	
η	coefficient of displacements increase due to torsion	5	
θ	interstorey drift sensitivity coefficient	5	
θ	chord rotation angle		4,7,9
θ	angle between the member axis and the direction of cracking		
θ_{pl}	plastic rotation		6
θ_u	ultimate rotation		6,9
θ_u	available chord rotation at the edge of the structural member	7	
θ_u^{pl}	ultimate plastic rotation		7,9
θ_{um}^{pl}	average value of ultimate plastic rotation	7	
θ_y	yield rotation		6,9
λ	insufficiency index		2,5
λ	index ο μήκους available over the effective anchorage length	8	

BODY

λ_c	coefficient of masonry strength increase due to the confinement of the surrounding R/C members	7	
$\bar{\lambda}_k$	mean value of the insufficiency index	2, 5	
λ_m	conversion factor of mean to characteristic strength	7	
λ_s	reduction factor for the inclined load application	7	
λ_s	coefficient expressing the contribution of bond	8	
μ	friction coefficient		6,8
μ_Δ	yield displacement		
μ_δ	displacement ductility of a building	6,7,8	
$\mu_{\delta i}$	displacement ductility of member I	8	
$\mu_{\delta u}$	displacement ductility capacity	7	
μ_θ	rotation ductility	4,6,7	
μ_φ	curvature ductility		4,7
$\mu_{(1/r)}$	curvature ductility		4,6,7,8
v	normalized axial force		7,8
v_{top}	normalized axial force of overlying column	7	
			Chapter
ξ_{cu}	height of compression zone normalized to the effective depth, at concrete failure	7	
ξ_{su}	height of compression zone normalized to the effective depth, at steel failure	7	
ξ_y	height of compression zone at yield	7	
ρ	reinforcement ratio		6,7
ρ_δ	minimum reinforcement ratio for interface reinforcement	8	
ρ_d	reinforcement ratio for diagonal reinforcement	7	
ρ_j	reinforcement ratio for external reinforcement	7	
ρ_s	reinforcement ratio for transverse reinforcement	7	
ρ_{tot}	total reinforcement ratio for longitudinal reinforcement (tension+compression+intermediate)		7,8
ρ_w	reinforcement ratio for transverse reinforcement	8	
σ_o	normal compression stress		6
σ_2, σ_3	maximum effective transverse compression stress due to confinement	6	
σ_{cd}	design value of the total normal stress at the interface	6	
$\sigma_{j,crit}$	critical value of stress in the strengthening material	8	
$\sigma_{j0,max}$	yield stress of the steel plate (leaf) or tensile strength of FRP	6	
σ_{jd}	design value of effective stress in the external transverse reinforcement	8	

BODY

σ_N	compression stress (at the cracking interface)		8	
σ_s	stress in the steel under tension		6	
τ	shear stress			7
τ_1^+, τ_1^-	shear stress during the first or second half of a cycle	6		
τ_b^{det}	detachment shear stress		8	
τ_c	shear stress along the diagonal tensile cracking of a joint core	7		
τ_e	shear resistance		9	
τ_{fitRd}	maximum shear resistance at the interface		9	
τ_{fRd}	design value of the maximum shear resistance due to friction	6		
$\tau_{\text{fl(s)}}$	shear resistance during the first cycle		9	
$\tau_{\text{fn(s)}}$	reduced shear resistance after n cycles		9	
τ_{fu}	contribution of friction to the shear strength		6	
τ_{fud}	design value of shear strength due to friction during the first cycle		6	
τ_{fud}	total shear resistance at the interface			9
$\tau_{\text{fud,n}}$	shear resistance reduced due to cyclic loading after n cycles		6	
τ_j	mean value of shear stress in the joint core		7	
τ_{ju}	shear stress in the joint core at failure due to diagonal compression		7	
$\tau_{\text{Rd,int}}$	design value of shear strength at the interface		6	
τ_u	shear strength			6
φ	reduction factor		7	
χ	height of compression zone		7	
ψ	reduction efficiency factor when more than one layer of FRPs are used	8		
ψ_i	design coefficient for variable actions			4
ω	mechanical volumetric ratio of reinforcement under tension		7	
ω'	mechanical volumetric ratio of reinforcement under compression		7	
ω_w	mechanical volumetric ratio of confinement reinforcement		6,7	
ω_{wd}	mechanical volumetric ratio of confinement reinforcement (design value)		7,8	
ω_{vd}	mechanical volumetric ratio of web reinforcement		8	

CHAPTER 1

SCOPE – FIELD OF APPLICATION – OBLIGATIONS AND RESPONSIBILITIES

1.1 SCOPE

1.1.1 Scope of the Standard

The scope of the present Standard is the enactment of criteria for the assessment of the structural capacity of existing structures, and of rules of application for their redesign replanning, as well as for potential interventions, repairs or strengthening.

1.1.2 Commentary

In correspondence to the articles of the present Standard, the relevant Public Authority also publishes a commentary which constitutes an integral part of the Standard and refer to issues of special interest, remarks that help in the comprehension of the text, or methods with limited field of application which may be applied under certain conditions.

1.1.3 Provisions with mandatory application

The present Standard contains provisions with mandatory application, which define:

- a. The criteria for the assessment of the structural capacity of an existing structure

The level of sophistication of the requirements of the structural checks are determined in correlation with the aim of the checks.

The procedure and criteria of assessment of structural capacity proposed by the present Standard constitute a set of rules, the fulfilment of which implies that the fundamental conditions of structural efficiency of a structure or its parts are satisfied.

The minimum mandatory requirements of structural capacity that must be

BODY

satisfied in the case of existing structures can, under certain conditions, be less strict than their counterparts in Standards for the design of new structures that are in effect at the time of the assessment.

The application of methods other than those included in the present Standard is acceptable provided that they ensure at least the same level of safety, they are scientifically sound and have the approval of the relevant Public Authority.

The interventions on existing structures usually involve “particularities” which cannot always be fully by the present Standard, which defines the framework for the design and construction of the intervention works.

The minimum mandatory requirements of structural capacity that must be satisfied in the case of existing structures, can, under certain conditions, be less strict than their counterparts in Standards for the design of new structures than are in effect during the time of the intervention.

The obligatory minimal requirements that must be satisfied before and after the intervention, are determined in correlation with the type of the structure, its use, time of construction, and the Standards in effect at that time.

This Standard defines the means with which each intervention can be carried out. The Standard does not restrict the Engineer who wishes to perform more precise calculations than those required in most cases.

To allow for the application of more precise methods, the latter should meet the required criteria (accuracy of models etc.) and to be accompanied by evidence of their reliability and towards achieving the safety level required by the Standard while – in any case – being subject to approval by the relevant Public Authority.

- b. The minimum mandatory requirements of the structural capacity of redesigned structures or their parts.

- c. The specification of the ways an intervention can be carried out.

This Standard applies in parallel with current Earthquake Standards and Standards for the design of structures made of specific materials (e.g. concrete), which include the relevant specific criteria as well as detailed and practical detailing rules.

For structures that have been built according to earlier Standards, especially for those without seismic design (using only traditional construction rules), it is likely that the complete satisfaction of current requirements is practically unrealistic.

Acceptance of partial fulfilment of the requirements of the aforementioned Standards, or the satisfaction of the requirements of earlier Standards can be granted either by explicit reference in the present Standard or by decision of the relevant Public Authority.

A decision of the relevant Public Authority sets out the necessary exemptions from the provisions of the Urban Planning Law (in analogy with what applies for earthquake-ridden structures), to allow the construction of strengthening works that arise from the application of the present Standard.

In structures that are checked and/or redesigned by this Standard it is not allowed to modify structural elements, load-bearing or not, or change the use of the structure before studying the effects of these changes.

Special reference shall be made in a technical report regarding maintenance measures which is foreseen in Chapter 11.

As structures are defined buildings, bridges, retaining walls, tanks, silos etc., regardless of the material and the form of the structure.

Given that the provisions of this Standard refer also to accidental (mainly seismic) loads which may be exceeded, that the available knowledge is rapidly increasing and that there are also financial limitations involved, it should be clearly understood that, even if the rules of the present Standard are fully applied, taking into account the inherent uncertainties, the possibility of failure

- d. The interrelation of this Standard with other Standards (i.e. regarding materials, loads etc.)

1.2 FIELD OF APPLICATION

1.2.1 General

- a. This Standard concerns the assessment of the structural capacity and the seismic redesign of existing structures or their members.

of the structure can not be ruled out.

An intervention on the infill elements of a structure also constitutes an intervention on an existing structure.

The present Standard covers "normal risk" projects, i.e. projects whose potential failure is limited to the project itself, its content and in its immediate vicinity. The Standard does not cover 'high risk' projects, i.e. those whose potential failure could have serious consequences over a large area outside the project area (e.g. dams and marine projects).

For these projects the required safety level will be determined by additional special provisions.

The present Standard requires that there will be a safeguard against poor workmanship or errors due to inexperience, which constitute a major cause of failure of structures.

In order to safeguard against such errors, this Standard can be applied only by engineers who possess the formal and substantive qualifications (education, experience, ability) that are stipulated by decision of the Public Authority.

The term "visible damage refers" to damage that can be detected by visual inspection and examination.

Checking of an existing structure in cases other than building additions or change of use where, typically, a check is required, may also be imposed in the following cases:

- Structures without structural design / calculations or without approved calculations (illegal construction)
- Structures with structural calculations but without seismic

- b. The principles, criteria and rules of interventions and redesign contained in the present Standard are intended to be of general application, while the rules of application refer mainly to reinforced concrete buildings (damaged or undamaged).
- c. "High risk" projects are not covered by the present Standard.

- d. The application of the present Standard requires engineers with the necessary technical expertise and the relevant qualifications.

1.2.2 Undamaged structures

- a. The present Standard covers the checks of existing structures without any obvious damage or deterioration, as well as the potential seismic redesign of these structures.
- b. The cases where check of existing structures is mandatory are determined by decision of the Public Authority.

design

- Structures with structural calculations including seismic design but in an area where a higher seismicity was designated since their construction
- Structures with increased vulnerability (e.g. pilotis, short columns etc.).

The upgrading of the level of safety may be requested by the owner, so that the existing structure meets the requirements of the current Standards (in whole or in part).

Treatment of heavy wear and damage due to physicochemical actions will be covered by additional provisions.

Interventions in cases of damage due to fire will be the subject of a dedicated Standard.

The general principles and interventions foreseen by the present Standard apply in all cases and are supplemented by the provisions of the Annexes and / or special Standards.

The owner of the structure may choose between simple rehabilitation in compliance with the minimum mandatory safety requirements set by the State, or rehabilitation and strengthening beyond the minimum mandatory requirements.

- c. The present Standard foresees the necessary checks (Chapter 3) and describes any necessary interventions (Chapters 4 and further) in order to upgrade the level of safety of an existing structure.
- d. This Standard defines the requirements of the redesign for each case, according to the previous paragraphs.

1.2.3 Damaged Structures

- a. The present Standard covers the checks, repairs or strengthening and seismic redesign of existing structures which have sustained damage.
- b. All pathological causes of structural damage are covered by the present Standard, but reliable criteria for redesign are given only for the most common among them.
- c. The present Standard specifies the conditions under which the redesign and strengthening of the damaged existing structure is mandatory, and those under which simply a repair of the structure is sufficient.

1.3 OBLIGATIONS AND RESPONSIBILITIES OF PARTIES INVOLVED IN THE DESIGN-EXECUTION OF WORKS, AS WELL AS USERS

1.3.1 General

- a. The design, construction and use of structures under a combination of actions including accidental actions, such as earthquake, is done in such a way as to ensure the satisfaction, in whole or in part, of the following requirements, depending on the desired performance level:
 - The probability of collapse of the structure (or part thereof) to be sufficiently small;
 - The damage of elements of the structure under the design earthquake to be limited and repairable;
 - Minimize damage for inferior actions; and
 - To ensure a minimum operating level of the structure, depending on its use and importance.
- b. Existing structures:
 - Reflect the degree of knowledge during the period of their design and construction;
 - Probably embody hidden faults; and
 - May have been subjected to unknown stresses and effects.
- c. According to the Standards for new structures, a certain probability of failure is acceptable.
By including the uncertainties already involved in the design stage of existing structures, the level of uncertainty and the probability of failure is increased.
These uncertainties should be considered when determining the obligations and responsibilities of the parties involved in the projects.
- d. The provisions of the present Standard assume that the Engineer responsible for the design possesses the necessary qualifications and

For example, the design earthquake has a 10% probability of exceedance during the intended life span of ordinary constructions, equal to 50 years.

See related Paragraph 1.2.1 [d].

the appropriate experience concerning the type of structures to be checked, repaired or strengthened.

1.3.2 Responsibilities

When intervening in order to strengthen or repair an existing structure, among the technically sound solutions, the one that leads to the optimization of the cost of the intervention and reduces any related future costs should be selected (also depending on the remaining life of the structure).

The designer Engineer must suggest all the necessary safety measures to the owner, prior to any works.

The designer Engineer has the obligation of developing a complete and technically sound design of the intervention.

The supervising Engineer is on charge of the complete technical implementation of the approved design of the intervention.

The other parties involved are required to perform the intervention works according to the design, the present Standard, the applicable technical standards and guidelines, and the state of the art, while taking all the necessary safety measures.

1.3.3 Responsibilities

For the determination of any kind of responsibilities, the level of reliability of data regarding the assessment and redesign, reference to which is made in later chapters of the present Standard, should always be taken into account.

The responsibility for the monitoring and for the evaluation of any required investigation works lies with the operator of these works, who should be qualified accordingly.

The designer Engineer is not responsible for the reliability of the results of these investigation works, unless he has undertaken their execution.

The responsibility of the designer Engineering in the phase of assessment & documentation consists of the submission of the relevant well-substantiated proposals to the owner, which should be in accordance with current Standards.

The findings of the inspection / documentation of an existing structure are based on current knowledge and current commonly recognized technical standards,

The responsibility of the designer Engineer with respect to the check of existing structures is limited to the proper execution of the check as defined in the present Standard.

The findings of the inspection / documentation of an existing structure may not be used for purposes other than those foreseen in the present

rather than those valid at the time of construction of the existing structure. From this perspective, the results of the investigation do not substantiate legal responsibility of the parties involved in the construction of the existing structure.

The responsibility of the designer Engineer involves the proper preparation of the design of the intervention in accordance with the provisions of the present Standard for the chosen performance level.

The responsibility of the supervising Engineer is to properly supervise the intervention works in accordance with the provisions of the present Standard, with the aim to implement the approved design, using technically sound methods.

The responsibility of other parties involved in the project consists of the workmanlike execution of the works according to the present Standard, the design of the intervention, the applicable technical specifications and instructions and the state of the art, as well as the observance of the indicated safety measures.

Standard.

The designer Engineer is not responsible for any failures that may be caused by a random event (e.g. earthquake) during the collection of the required data, unless the cause of failure is proved to be works that were suggested by him.

If a simple rehabilitation (repair) or local strengthening of members of the existing structure is made, the responsibility of the parties involved in the rehabilitation project is limited to the proper execution of the works in accordance with the present Standard, while responsibility for the overall safety of the structure remains with the parties involved in the construction or the original project.

The responsibility of the owner of the structure is to choose the performance level, which can not be lower than that prescribed by the Public Authority.

The responsibility of the users of the structure is to maintain the structure in good condition in accordance with applicable law, and to avoid any type of modifications without first studying the effects of these modifications.

In no case liability for potential damage of an adjacent building may be imposed because of the fact that a neighboring building has been strengthened against earthquake (see also Section 4.8.3).

CHAPTER 2

BASIC PRINCIPLES, CRITERIA AND PROCEDURES

2.1 ASSESSMENT OF EXISTING STRUCTURES

2.1.1 General

The assessment of existing structures follows the steps below:

- Collection of data (investigation of structural history)
- Analysis, and
- Verification against limit states.

2.1.2 Scope

- a. The purpose of the assessment of an existing structure is the evaluation of its available bearing capacity and the verification of meeting the minimum mandatory requirements imposed by the existing codes.
- b. To estimate the available bearing capacity of the structure the data from the structural history survey should be taken into account (see Chapter 3).
- c. The designer is ought to schedule and supervise a series of investigating works (see chapter 3) in order to document and justify the assumptions on which the assessment will be based.
- d. The process of assessment differs depending on the existence or not of damage in the building assessed.

Damage in the existing structure may be due to any past actions, prescribed or not by the Standards.

This part of the assessment is practically applicable where the damage is limited. It may be omitted, based on engineering judgment, when the referred in the following part (ii) are applied.

- e. In case of no damage, the result of the assessment, depending on the foreseen redesign objective (see Section 2.2 below), will dictate the decision for potential retrofit.
- f. In the case of existing damage, the assessment process is distinguished in two parts:
 - (i) First, the structure is assessed as it is, taking account the damage. Depending on the foreseen redesign objective, the result of the assessment will lead to a decision for intervention (repair and / or retrofit) or not.
 - (ii) In case that intervention is required, the structure is assessed to its pre-damage status, i.e., simply assuming that damage will be repaired. Depending on the foreseen redesign objective, the result of this assessment will lead to the decision for simple repair or for repair and retrofit.

2.1.3 Collection of data

The collection of the data required for the assessment shall be governed by the following principles:

- a. The data required to assess the bearing capacity of existing structures (see Chapter 3), should be wherever possible, cross-verified and calibrated properly.
- b. The program of field and laboratory investigations is recommended be made, and its execution to be supervised by the designer of the assessment, according to the specific design requirements.
- c. The reliability of the data collected should be properly taken

Three levels of data reliability are adopted; high, satisfactory and

tolerable (see Section 3.6.2). The consequences of this classification are described in Chapters 3, 4, 5, 9 and 10.

into account in assessing the existing structure and developing the intervention strategies.

2.1.4 Assessment principles

2.1.4.1 Generalities

In this case, the accuracy of the assessment method used should be adjusted to the desired goal. For instance, an approximate, yet conservative, assessment method is sufficient to demonstrate the adequacy of the existing load-bearing system against vertical loads. Apparently, when the existing load-bearing system is expected to be fully dismantled, its assessment is not necessary.

For the assessment (of the structure) against vertical loads it is possible to use the methods prescribed by EC 2 (EN 1992-1-1:2004), appropriately adapted to the present Standard.

Assessment of existing structures follows the principles listed below:

- a. When the existing load-bearing system is expected to participate in the configuration of the redesigned structural system by resisting solely vertical loads, its assessment may be performed based on simple, yet conservative, methods.
- b. When, however, the existing load-bearing system is expected to participate in the configuration of the redesigned structural system by resisting both vertical and seismic loads, it should be assessed based on the following principles:
 - i) The assessment is made by analytical methods as specified in Chapter 5 of this Regulation. Especially in structures for which the available approved study (which has been applied) and

Issue of such specific provisions may be made, provided that they refer to a building stock with common, known, features, and that they always follow a relevant investigation which demonstrates that these simplifying provisions are compatible with the requirements of Section 5.1.1 of this Standard.

The possible interpretation of damage in terms of mode and location consists an acceptance criterion for of the analytical methods used. Possible parameters may involve non-visible geometrical data, mechanical characteristics that have not been investigated, random combinations of actions allegedly applied in the past etc.

- which do not harm, the assessment could be based on the contents of the approved design.
- ii) The numerical models to be used for the assessment may represent the entire structure or individual members. Different numerical models may be used, depending on the type of the imposed actions. In general, the types of numerical models should be determined by the calculation methods to be applied.
 - iii) It is recommended that the accuracy of the methods used, be compatible with the accuracy of the data.
 - iv) The use of empirical-analytical or purely empirical methods is allowed only in cases covered by relevant special provisions issued by the Public Authority.
 - v) In cases of structures that already present damage or deterioration, the applied assessment method must be able to interpret, as a rough approximation, both the mode and the location of these significant damage. In structures of great importance, where damage has been identified, parametric analyses may be required in order to achieve the interpretation of damage based on their mode and location.
 - vi) For analysis, limit states control, verification of the adopted behavior factor, control of the imposed displacements and local ductility

indices, the provisions of Paragraphs 2.4.3 to 2.4.5 of this Standard are of proportional applicability. Especially for masonry walls, the next Paragraph 2.1.4.2 is applied.

- vii) In many cases, a quick assessment of the loss of bearing capacity of a damaged or degraded structure may be useful and/or necessary. This estimate can be made based on the intensity and extent of damage, as derived according to valid (sophisticated or approximate) methods (see Paragraph 5.3 and Annex 7D).

2.1.4.2 Consideration of masonry infill walls

To calculate the internal forces of the structure due to non-seismic actions (e.g. due to vertical loads) numerical models shall be used that will be either lacking of masonry infill walls or will not impose stresses to the masonry infills.

The inclusion of masonry infill walls generally contributes towards more accurate approximation of the behavior of structures under seismic loading, especially during the assessment phase.

The assessment of detrimental or favorable influence of infill walls has to be made by the designer; however, the difficulty of the assessment has to be noted, particularly in case that analysis data and calculations are not available. As a result, the above assessment will be on the safety side, if the masonry infills are introduced in advance to the numerical analysis models.

- a.** It is not permitted to consider masonry infill walls as part of the system that bears non-seismic actions.
- b.** It is recommended to consider masonry infill walls as part of the system resisting seismic actions.
- c.** It is mandatory to consider masonry infill walls as part of the system resisting seismic actions, when this decision has an adverse effect to the results obtained for the load-bearing structural system at a global or local level.
- d.** For the conditions of application of the above, cases of exception, etc., the referred in Paragraph 5.9 apply.

In these cases, the infill walls are monolithically connected to the frame, and hence, they also participate in resisting non-seismic forces.

- e. The present Standard does not refer to load-bearing masonry wall infills that have been constructed simultaneously with the frame.

2.2 ASSESSMENT AND REDESIGN OBJECTIVES

2.2.1 General

- a. For serving broader socio-economic needs, various “performance levels” (target behaviors) are stipulated under relevant prescribed design earthquakes.
- b. The objectives of the assessment or redesign (Table 2.1) consist combinations of both a performance level and a seismic action, given an "acceptable probability of exceedance within the technical life cycle of the building" (design earthquake).
- c. In the present Standard, reassessment objectives are prescribed, that refer solely to the load-bearing structural system. In contrast, no objectives are set for the non-load-bearing system.

The relevant provision of EC 8 (R 3, § 2.1 (2)) is fulfilled through Table 2.1. In case of two (2) reassessment objectives, the possible pairs are B1 and A2 or C1 and B2.

The term "load-bearing system" is used here in the classical sense and corresponds to the system bearing vertical loads. Accordingly, the term "non-bearing system" corresponds to the system that does not participate in bearing vertical loads. It is noted that the above conditions are not associated with the terms “primary” and “secondary” structural elements that are used in subsequent paragraphs.

The objectives of the assessment or redesign are not necessarily

identical. The objectives of redesign may be higher than those of the assessment.

The minimum acceptable assessment or redesign objectives for the load-bearing system of existing buildings are defined ad-hoc by the Public Authority. In special cases, the Public Authority may designate additional objectives of assessment, or redesign of the non-bearing system as well. In this case, the same Authority also defines the criteria for meeting the respective objectives.

In any case, the reassessment objective (assessment or redesign) is chosen by the project owner provided that it is equal to or higher than the above minimum acceptable objectives. In defining these objectives, the following criteria (among others) shall be taken into account:

- Social impact of the building (eg, temporary construction, ordinary residential houses, area of public gathering, areas of crisis management, high-risk facilities).
- Available financial resources into the community during the given period.

The owner of the project or the Public Authority shall define the time frame within which the relevant interventions will be conducted, where required.

A nominal technical life cycle equal to the conventional lifetime of 50 years is generally accepted, regardless of the estimated "actual" remaining life of the building. An exception to this rule is permitted only under very special circumstances where the remaining lifetime is fully guaranteed, based on the judgment and approval of the Public Authority; in such a case, the seismic actions prescribed in Chapter 4 are modified accordingly.

It is indicatively noted that according to Table 2.1, the design

objective B1 is set for new structures.

The adoption of an assessment or redesign objective with a probability of exceedance of the seismic action of 50% will generally lead to more frequent, more extensive and more severe damage compared to a corresponding objective with a probability of exceedance of seismic action equal to 10%.

The probability of exceedance of 50% (maximum tolerable) in 50 years corresponds to an average return period of about 70 years, while a probability of exceedance of 10% in 50 years corresponds to an average return period of approximately 475 years.

In cases where the use a global behavior factor (q) is permitted for the entire structure, the selection of a specific assessment or redesign objective for the load-bearing structure implies the use of an appropriately modified factor, the values of which are prescribed in Chapter 4.

The criteria and rules for the assessment and redesign of the structure are given in Chapter 9 of this Standard.

Table. 2.1 Assessment or redesign objectives of the structure

Probability of exceedance of seismic action within a conventional life cycle of 50 years	Performance level		
	Immediate Occupancy	Life Safety	Collapse Prevention
1. 10%	A1	B1	C1
2. 50%	A2	B2	C2

2.2.2 Structural performance levels

The performance levels of the structure are defined as follows, particularly for the purposes of this Standard:

- a. "Immediate Occupancy after the earthquake" (A) is a condition in which it is expected that no building operation is interrupted during and after the design earthquake, with the possible exception of minor importance functions. A few hairline crack may occur in the structure.

Injuries of certain individuals due to structural damage or falling elements of the non-bearing structure or other objects are not excluded.

The term non-repairable damage, refers to serious or severe damage, for which strengthening (and not just repair) or replacement or substitution of the component or the entire structure is required. For reference, see also Annex 7D.

Such modifications are usually the alteration of geometric and / or mechanical characteristics of structural members, as well as the addition of new or the removal of existing members. By this definition, any repair and / or strengthening is an intervention.

- b. "Life Safety" (B) is a condition in which repairable damage to the structure is expected to occur during the design earthquake, without causing loss or serious injury of people and without substantial damage to personal property or materials that are stored in the building.
- c. "Collapse Prevention" (C) is a condition in which extensive and serious or severe (non-repairable, in general) damage to the structure is expected during the design earthquake; however, the structure retains its ability to bear the prescribed vertical loads (during and for a period after the earthquake), in any case without other substantial safety factor against total or partial collapse.

2.3 GENERAL PRINCIPLES FOR INTERVENTION DECISION MAKING

Apart from the provisions of EC 8 (P3, § 5) the following apply:

2.3.1 Definitions

- a. The term structural **intervention**, implies any operation that results in the foreseen modification of existing mechanical characteristics of a member or a structure and has as a consequence, the modification of its response.
- b. The term **repair** implies the intervention process to a structure damaged by any cause that reinstates the mechanical characteristics of its structural members to their pre-damage level and restores its original structural capacity.

- c. The term **strengthening** implies the intervention process to a structure with or without damage, which increases the capacity or ductility of a member or the entire structure to a level higher than that prescribed in the original design.

2.3.2 Post-earthquake immediate safety measures

The nature and the extent of these measures shall be related to the degree of the observed damage or deterioration and the possibility of aftershocks (see Chapter 3 of this Standard).

After a strong earthquake, feasible protective measures shall be urgently taken aiming to the safety of the population and the minimization of further damage or loss.

2.3.3 Pre-and Post earthquake interventions

2.3.3.1 Selection criteria and types of structural interventions

Such general criteria are deemed the following:

- The cost, both initial and long term (i.e., the cost of maintenance and possible future damage or deterioration), compared to the importance and age of the building examined.
- The available quality of the work (it is extremely important that intervention measures are compatible with available resources

- a. Based on the conclusions drawn during the assessment of the structure and the nature, extent and intensity of the damage or deterioration (if any), intervention-related decisions are made, with the aim to (a) meet the basic requirements of the seismic code, (b) minimize the cost and (c) serve the social needs.
- b. The selection of the type of the structural intervention shall be made, primarily on the basis of general cost- and time-related criteria, the availability of the resources required, architectural or other needs, etc. In this selection, the financial (or other) value of the structure shall also be taken into consideration, both

and available quality of work).

- The availability of an adequate quality control.
- The use of the building (possible consequences of the intervention works to the use of the building).
- The design, from an aesthetics point of view (the intervention scheme may vary between a fully invisible intervention and a deliberately distinctive set of new or added members).
- The conservation of the architectural identity and integrity of historic buildings and the consideration of the degree of reversibility of the interventions.
- The duration of works.

Such technical criteria are deemed the following:

- All identified serious deficiencies must be restored accordingly.
- All identified serious damage (and deterioration) in primary structural members must be restored properly.
- In case, of highly irregular buildings (mainly in terms of distribution of their overstrength), structural regularity shall be improved to the maximum possible extent.
- All resistance requirements in critical regions of primary structural members (i.e., the required resistance and plastic deformation capacity) must be satisfied after intervention (on the distinction between primary and secondary members see Chapter 5).
- Where possible, the increase of local ductility in critical regions shall be pursued. Particular provision shall be taken, to the greatest extent possible, so that the local repair and / or strengthening does not diversely affect the available ductility within the critical region.
- In special cases, the durability of both new and original

prior and after the intervention.

- c. The selection of the type, technique, scale and urgency of the intervention shall be based on technical criteria related to the observed current state of the building, as well as to a provision to maximize the ability of the structure to absorb seismic energy (ductility) after the intervention.

structural members and the potential acceleration of the deterioration, shall be taken into consideration.

A number of technical and managerial strategies are indicatively given herein:

Technical strategies

- Enhancement of the building strength
- Enhancement of the building stiffness
- Enhancement of the deformation capacity of the structural members
- Reduction of seismic demand

Managerial strategies

- Limitation or change of use of the building
- Partial or global demolition (i.e., of a number of storeys)
- Rigid body transfer of the entire structure to another location
- Decision for “no intervention”. In such a case, a reduction of the technical life cycle of the structure can be accepted, under the condition that upon expiry of this period, the demolition of the structure is guaranteed.

Some types of interventions in structural elements associated with specific strengthening strategies of technical nature are referred below.

- The enhancement of strength and stiffness is alternatively achieved by selective or large scale strengthening of structural members or by the addition of new elements that can resist either partially or totally the seismic actions (e.g. reinforced concrete

2.3.3.2 Types of intervention and their consequences

- a. Based on the foregoing criteria and the results of the assessment of the structure, appropriate forms of intervention should be ad hoc selected for individual structural members or the entire building and the non-bearing structural system (if required); always taking into account the side effect of the interventions on the foundations. This selection is part of an intervention strategy, which aims to improve the seismic behavior of the building by modifying or certifying the basic parameters that affect its seismic behavior. In order to achieve a reduction of seismic risk, strategies of technical or managerial nature or combination of the two can be adopted.

shear walls, steel trusses, infill walls etc). In this case, particular attention should be given to the design of the foundation due to the increase of both the structural mass and the seismic loads.

- The enhancement of post-elastic deformation capacity is achieved by improving the confinement of existing members, e.g. with external connectors, strips of steel or fiber reinforced polymers, etc.
- The reversal of critical deficiencies refers to lifting those features that lead to unfavorable seismic behavior. Indicatively:
 - Modification of the structural system (abolition of certain expansion joints, replacement or substitution of sensitive members, alteration actions towards a more regular and ductile configuration)
 - Addition of special links to connect the brittle masonry and surrounding member, whenever this is permitted by the strength of masonry
 - Local or global modification of members with or without damage
 - Full replacement of insufficient members or members that have suffered extensive damage
 - Redistribution of demand (e.g. through external prestressing)
- The reduction of seismic demand is achieved by reducing the mass of the structure and the modification of the structural system towards a favorable shift of the fundamental period of the structure (e.g. through seismic isolation systems or absorption of seismic energy, which however are not covered by this Standard. Compare Chapter 10 of EC 8), etc.

In such case, local or global collapse shall be prevented by:

- Appropriate links to the load-bearing members or by taking supportive measures to prevent possible fall of parts of those members
- The improvement of the mechanical characteristics of non-bearing structural members.

The enhancement of strength usually leads to a reduction of ductility, unless special measures are taken (e.g. in reinforced concrete elements, the increase of the tensile reinforcement should be in principle accompanied by a sufficient increase of the compression reinforcement and the confinement).

b. In cases where, for the redesign objective set, the seismic behavior of non-bearing structural members might endanger the lives of the occupants (or third persons), or might have consequences to stored goods, measures shall be taken to repair or strengthen the particular members.

c. The potential impact of repairs and strengthening of non-bearing structural members shall be taken into account.

d. The side effects of all structural interventions on the local and global capacity of the building to absorb seismic energy shall be taken into account.

2.4 REDESIGN

2.4.1 General

The redesign of existing structures follows these steps:

- Conception and preliminary design
- Analysis, and
- Verification against limit states.

2.4.2 Conception and preliminary design

Decisions on the appropriate in each case strategy and the subsequent type of interventions shall be formed by exploiting all the information obtained during the assessment stage of the existing structure. Dominant in the decision-making process must be the perception of the overall behavior of the building and the identification of its weaknesses, such as, e.g. the lack of strength or stiffness or ductility, the unfavorable structural system, inadequate individual characteristics, etc.

Regardless of the analysis method of the redesigned structure that will be eventually adopted, inelastic static analysis may provide substantial assistance in identifying these weaknesses (see Paragraph 5.7). Furthermore, with the aid of the above method, it is feasible to preliminary decide the characteristics of the types of intervention that will be prioritized.

See also relevant Paragraph 2.4.5.

- a. According to the estimates of Paragraphs 2.3.3.1 and 2.3.3.2 of the present Standard an intervention strategy is drawn and the type and extent of interventions is decided.

- b. In any case, this selection shall be justified (compared with other possible options) while the anticipated post-intervention behavior of the building shall be also described qualitatively.
- c. Preliminary estimate shall be made of the dimensions and strength of the materials used and the modified stiffness of the structural elements where intervention is made.
- d. Preliminary estimate shall be made of the ductility class that the structure will fall into after the intervention or, (in case of application of inelastic static analysis) preliminary estimate shall be made of either the amplitude of the target displacement or the tolerable rotation angle of all structural members after intervention.

2.4.3 Analysis

To determine the internal forces and displacement, it is permissible to ignore proximity to other buildings. See relevant Paragraph 4.8.

Whenever possible, it is recommended to calibrate such methods through comparison with the behavior of buildings that have been already studied with the particular methods.

As part of the redesign process, it is desirable to make every effort to mitigate the potential deficiencies imposed by the masonry infills. Addition or upgrading of masonry infills can be used for the improvement and strengthening of existing buildings, subject to the conditions of this Standard.

2.4.3.1 Generalities

- a. The action effects and / or the required plastic rotations of all structural members of the building, under the design earthquake and other combinations of actions, are derived by appropriate analytical methods as particularly prescribed in Chapter 5 of this Standard.
- b. The selection of the appropriate method of analysis shall be based on the importance of the building and its potential damage or deterioration, as well as on the available data as regard to the sections and strength of its structural members.
- c. Where appropriate, augmentative partial factors γ_{sd} will be applied to account for the additional uncertainties related to the numerical analysis models.

2.4.3.2 Consideration of masonry infill walls

Consideration of the masonry infill walls in the redesigned structure may be made subject to the conditions of Paragraph 2.1.4.2.

2.4.3.3 Methods of analysis

For the assessment and redesign of a building, one of the

following analysis methods may be used. The field of application of each analysis method depends on the fulfillment of a series of conditions, primarily regularity-related (Chapter 5).

- a.** Elastic (equivalent) static analysis with global (q) or local (m) behavior or ductility factors, subject to the conditions of Paragraph 5.5, regardless of the data reliability level.
- b.** Elastic dynamic analysis with global (q) or local (m) behavior or ductility factors, subject to the conditions of Paragraph 5.6, regardless of the data reliability level.
- c.** Inelastic static analysis, subject to the conditions of Paragraph 5.7. In this case, it is recommended to ensure, as a minimum, a “satisfactory” data reliability level.
- d.** Inelastic dynamic (response history) analysis, subject to the conditions of Paragraph 5.8. In this case, it is again recommended to ensure, as a minimum, a “satisfactory” data reliability level.
- e.** In special cases, solely for the assessment of existing buildings, it is permitted to analytically assess the demand approximately, without detailed analysis with the use of a finite element model of the entire

These indices are defined in Paragraphs 5.5.1.1 and 5.5.1.2 respectively.

The adopted threshold value of the failure index (λ) generally denotes that the available strength of each primary structural member is at least 40% of the demand resulting from an elastic seismic analysis without reducing the seismic action, that is, for $q=1$.

It is considered that the average failure index ($\bar{\lambda}_k$) detects the regularity in the resistance along the building height, whereas its adopted threshold value ensures that no weak, in flexure and shear, intermediate storey exists.

It is deemed that with this provision, issues of torsionally sensitive storeys are tackled.

building.

- f.** Apart from the above analytical methods, solely for the assessment of existing buildings, in special cases and for specific objectives, it is possible to use empirical methods (Paragraph 5.1.1).
- g.** It is permitted to apply the elastic methods described in Paragraphs 5.5 and 5.6 provided that the following simultaneously apply:
 - i) The failure index (λ) of each primary member is in general lower than 2.5.
 - ii) The average failure index ($\bar{\lambda}_k$) in each storey does not exceed 1.50 times the average failure index of the overlying and the underlying storey.
 - iii) The failure index (λ) of each primary structural member that is located in one side of the building, for a given direction of seismic action, does not exceed 1.50 times the average failure index (λ) of a primary member that is located in any other side of the same storey.

2.4.3.4 Principal (or primary) and secondary structural members

The main consequence of classifying a structural member (or individual entity) as a secondary is that for these members, different performance criteria apply, that is, it is permitted to undergo larger displacements and exhibit higher damage compared to the primary elements (see Chapter 4, 5 and 9).

In cases where the Immediate Occupancy after the earthquake has been set as the assessment or redesign objective, the above distinction between primary and secondary data is not permitted.

For the masonry infill walls, which do not bear vertical loads (see Paragraph 2.1.4.2), the distinction between primary and secondary members does not apply. Where, in this Standard, those members are considered as part of the system resisting seismic actions, they are addressed and verified separately.

See Chapter 6 for the numerical models, Chapter 7 for the determination of the behavior of structural members and Chapter 8 for the design of the interventions.

See Chapter 4, 7, 8 and 9.

The individual entities of the structure of a building and the individual structural elements (members) affecting the stiffness and demand distribution within the building, or the members that are loaded due to lateral building displacements, can be distinguished during assessment or redesign into “principal” (or “primary”) and “secondary”.

As principal, in general, will be characterized those structural members or individual entities that contribute to the strength and stability of a building under seismic loading. The remaining structural elements or individual entities will be characterized as secondary. Ssee also related EC 8 (P1, § 4.2.2).

2.4.4 Safety verification

- a. The available resistance in the critical regions of all structural members (i.e., the resistance quantities and / or the tolerable plastic rotations) shall be calculated on the basis of rational numerical models, which are widely accepted by the international scientific community, especially in terms of force transfer between existing and added materials or members.
- b. The partial factors of the existing and added materials shall take into account the geometrical uncertainties, the dispersion of material properties, the relevant information available on site, as well as any uncertainties due to the nature of works and the difficulties of effective quality

The damages limitation verification generally includes the primary and secondary structural members, infills and appendages.

In existing structures the requirements of capacity design, limitation of the axial force, local confinement, etc. have not been in general met. The consequence of this fact is the difficulty in assessing a global behavior factor.

Particularly when the values of the behavior factor are taken in accordance to Paragraph 4.6.2 during the assessment and in accordance to Paragraph 4.6.3, during the redesign, the reevaluation of the behavior factor is not required.

control.

- c. Where appropriate, dilutive factors γ_{Rd} shall be applied to account for the additional uncertainties arising from the numerical modeling of the resistance in critical (or non-critical) regions.
- c. In cases of structural interventions against seismic actions, the damage limitation verification will be made in accordance with the provisions of Chapter 9.

2.4.5 Verification of the adopted behavior factor

After the verifications of Paragraph 2.4.4, it is required to approximately reevaluate the predefined behavior factor for the repaired – strengthened building, taking into account all the criteria favoring energy absorption (see Paragraphs 4.6.2 and 4.6.3) such as:

- a. The sequence of failure of horizontal and vertical structural members.
- b. The type of failure in critical regions of each structural member (i.e., the ratio of the ultimate shear force over the effective shear at the time of flexural failure, as imposed by capacity design).
- d. The local available ductility in the critical regions

- e. The available secondary resistance mechanisms at large relative displacements
- f. The potential consequences of the brittleness of a limited number of structural members on the ductility of the entire structure.

CHAPTER 3

INVESTIGATION AND DOCUMENTATION OF AN EXISTING STRUCTURE

3.1 GENERAL

Damage or deterioration is recorded, whether caused by an earthquake or other actions (fire, environmental actions, etc.).

The reliability of data depends on many factors, including:

- Availability of an approved design
- Time period of the construction of the structure
- Adequacy of the investigation of material quality and building method
- Reinforcement detailing, reinforcement anchoring and detailing of starter bars.
- Method of construction, condition and characteristics of masonry walls
- Difficulties in the on-site assessment of the actual characteristics of the materials

- a. Before any design or intervention is carried out, it is needed to investigate and document the existing structure to a sufficient extent and depth so as to obtain maximum data reliability on which to base the assessment or redesign. This involves surveying the structure and its condition, compilation of the structure's history and maintenance, recording of any wear or damage as well as conducting on site investigation works and measurements.
- b. The desired Data Reliability Level depends on several factors, and affects the determination of the actions and resistances.

Depending on the intensity and extent of deterioration or damage and in regard to the usability of the building, the following cases are referenced:

- i. None or minor damage :
The building may be used without any restrictions.
- ii. Substantial damage :
The ability to use the building should be significantly restricted until a more accurate and final assessment is made. The possibility of supporting or shoring as well as other safety measures should be considered.
- iii. Severe damage, with or without collapse:
Access to the building and the surrounding area should be denied. The sections of the building that may suddenly collapse, should be immediately demolished; also, direct intervention measures should be considered (see § 3.4.a).

The inspection procedures, checklists and any other procedures of data collection will follow the standards of professional and public organizations, and should be compatible with the means available for inspection, investigation and for repair / strengthening. In case where no such Standards exist, the following indicative proposals, for a list of required information and data as well as the methodology, can be followed.

However, it may be difficult to always collect detailed information. In these cases, uncertainties can be covered by introducing the concept of “data reliability level” (see § 3.7).

Required Information:

- a. Identification of the structural system.
- b. Information on any structural changes that have occurred since construction, which may alter the behaviour and response of the building.
- c. Determination of the subsoil conditions (soil classification).

- c. During the investigation / documentation after an earthquake, all necessary security measures for residents and staff should be taken. The nature and extent of these measures and actions will depend on the damage intensity and the importance of the functions of the building.

- d. For the assessment of the condition of an existing structure, data will be collected from available public or private archives, from the relevant trustworthy and reliable information as well as from on site inspection and investigation.

BODY

- d. Determination the type and characteristics of the foundation.
- e. Determination of the potentially harmful environmental exposure class for the structure.
- f. Information on the dimensions and cross sections of the structural elements as well as on the condition of the materials which constitute the building, its construction method etc.
- g. Description of actual and / or planned use of the building (and determination of the importance factor).
- h. Evaluation of the live loads, taking into account the actual use of the various areas of the building.
- i. Information on the quality of existing materials, in quantitative terms if possible.
- j. Information on the type and extent of previous and current structural damage or deterioration, if any, including any measures of repair or strengthening taken.
- k. Information on any identified significant errors in the initial design, information on material defects and their description.
- l. Geometric measurements of:
 - Cross section dimensions, the length of the structural elements and thickness of finishes, as constructed.
 - Levelling, eccentricity measurements, deviation measurements, etc.
 - Cracks widths or detachments in concrete or masonry elements.
 - Deformation and discontinuities in joints, displacements, etc.
 - Permanent deformations.
 - Time development of the aforementioned phenomena especially due to aftershocks (with the possible installation of monitoring sensors).

3.2 SURVEY OF THE STRUCTURE

The survey also includes infill walls, which may be taken into account during the assessment and redesign according to the provision of the present Standard.

- a. The survey of the structural elements and the masonry walls is done in parallel to the architectural survey the drawing plans of which are used as background.
- b. The design of the interventions can be based on existing drawings of the structure, provided that there is an initial design and that it has been adequately

Any obligations and responsibilities regarding the scope and execution of the plan are given in Chapter 1.

The following should be included:

- i. Construction date, Design code used for the design, an estimate of the residual economic value of the building, and information from the quality control dossier (if one is available) during construction.
- ii. Evaluation of the design documents of the project dossier, which involves the examination of construction drawings and calculations.
- iii. Collection of information regarding the previous state of the building, including any previous repairs or reinforcing measures, behaviour during previous earthquakes, the pre-existing damage or wear, including information from excavations carried out in the structure's vicinity, etc. .
The behaviour during past earthquakes (also compared with the behaviour of other buildings on the site) is information that should be taken into account as means of comprehensive physical testing of the structure. Such information can significantly help calibrate the assessment methods as well as help in the decision process.

Wear or damage must be noted in the survey drawings, along with all the necessary clarifications.

implemented. Otherwise, the preparation of appropriate drawings of the structure is required (structural survey).

- c. For surveying hidden elements, the design engineer shall prepare a plan for investigative sections (or other type of investigations), in accordance with § 3.5.2.

3.3 HISTORY

- a. The compilation of the structure's history is required, namely the collection of information on:
 - Construction stages
 - Subsequent interventions or changes of use or loads etc
 - The occurrence of wear and damage in the past and their method of restoration.
 - Loads due to accidental actions (earthquakes, fire, collision, large construction project in the vicinity, etc.).
- b. The extent of the compiled structure history is proportional to the significance of the project. In private projects of limited scope, history can be a simple recording of information given by the owner.

3.4 RECORDING OF DAMAGE

- a. The recording of the damage of a building supplements the survey of the structure.

BODY

The following are classified as damage:

- Significant deformations or deviations
- Cracking or detachment
- Local failures and fractures
- Reduction of cross sections, scaling and spalling
- Corrosion of steel reinforcement and concrete sulphate attack.

The intensity and extent of damage as well as the effect of poor workmanship, are directly related to the residual load bearing / resistance capacity and the available safety or plasticity margins of the damaged structural elements and the structure as a whole, see also Appendix 7D.

- i. The immediate intervention measures can be:
 - Immediate demolition of parts likely to collapse
 - Removalal of loose or hanging elements
 - Reduction and / or removal of large loads
 - Shoring against vertical loads
 - Retaining against horizontal loads
 - Prohibiting the use of the building (in part or as a whole).
- ii. The selection of temporary emergency measures depends on several factors including:
 - The type and use of the building, coupled with its size and importance
 - The type of damage
 - Available resources (personnel, equipment, etc.)
 - The degree of urgency of the situation
 - The possible development of damage
 - The expected behaviour during aftershocks
 - The cost of the interventions.

b. The term "damage" is used to describe any deterioration or reduction of the geometry or the mechanical characteristics of the structural elements or the masonry walls.

This term also describes in general any type of wear, e.g. due to physicochemical actions.

- c. The workmanship defects that cause an impairment of the geometry or the characteristic of the structural elements, and can lead to a reduced bearing / resistance capacity and / or functionality, durability etc. should be recorded and taken properly into account.
- d. Accordingly, the possible damage of infill walls is also recorded and properly evaluated (see also § 3.2 [a]).
- e. Depending on the intensity and extent of damage, the need for immediate intervention measures is considered.

The appropriate measurements and tests can be performed on-site and / or in a laboratory. The choice of measurements and tests should be done according to Engineering judgment. However, in order to minimize any uncertainties, the information by all sources should better be confirmed.

The Designer on the basis of the aforementioned investigative work needs to justify the assumptions according which the assessment and redesign will be carried out, according to Chapters 2 and 4.

A useful tool for assessing the characteristics of materials is a publication of the Technical Chamber of Greece: "Methods for in situ evaluation of the characteristics of materials", Athens, 2002.

During the drafting of the investigations programme, the Designer should take into account the importance of the building as well as the type and methods of calculation to be used for the assessment and redesign.

See also the classification of structural elements in

3.5 INVESTIGATIVE WORKS

3.5.1 General

a. The investigative work is aimed at gathering information that may be useful for assessing the bearing capacity of the building.

The different parts of the investigation are distinguished depending on the type of the item being investigated:

- Survey of hidden elements.
- Material characteristics and the construction method.
- Foundation soil.
- Other parameters.

b. The Designer Engineer prepares the investigations plan, which is carried out by approved, for this purpose, laboratories.

For selecting the number and positions of samples, criteria like the following should be applied:

- The representativeness of samples or positions, and
- Local damage and imperfections of the structure that may have occurred, while
- A minimum number of tests should be determined so as to allow the statistical analysis or calibration.

c. The participation of each structural element in the

principle (or primary) and secondary elements according to § 5.1.2.

See also related Chapter 1.

For buildings which the design is available (which is implemented without substantial changes) or at least the design drawings are available, surveying of hidden elements can be limited to sample checks / confirmation of the implementation of the design drawings. Especially for reinforcement detailing, three (3) investigative sections per element category is considered necessary, with particular emphasis on anchorage and lap lengths in critical areas, as well as the detailing of shear reinforcement.

In buildings for which no drawings are available or there are significant deviations from the approved design, the extent of the investigation must be sufficient to provide reliable information for the assessment and redesign. This involves the need to measure the dimensions of all structural members and perhaps of the infill walls as well. In terms of cross-sections and reinforcement layout, it is practically impossible to identify them for every structural element and in every position. It is therefore necessary to select checking locations in accordance with the on the importance of each element for the seismic resisting capacity of the building.

However, for items for which direct measurements are difficult to achieve, the knowledge of the conditions and patterns of practice that existed at the time of construction could prove useful, so as to be able to draw reliable conclusions with a minimum number of investigating sections.

seismic resistance of the structure must be taken into account.

d. The monitoring and evaluation of the results of the investigations, is carried out by the Designer or by another sufficiently qualified engineer.

3.5.2 Survey of hidden elements

The existence of hidden structure elements is examined, by investigative sections or by instrumental testing methods, in order to specify:

- The structural form (including foundation).
- The type and geometry of the infill walls and plastering / coating / flooring.
- The construction details of infill walls.
- Cross section and reinforcement layout of reinforced concrete elements.
- The reinforcement details (concrete cover, anchorages, reinforcement laps, hooks, bends etc).
- The presence of other materials that may be part of the structure (metal, wood, plastic etc.).

3.5.3 Mechanical characteristics of the construction materials

The main construction materials referenced in the

provisions of the present Standard are concrete and reinforcing steel, and potentially masonry walls (bricks and mortar).

a. The required characteristics are mainly the compressive strength (and Elastic modulus) of concrete, yield strength, tensile strength and maximum strain of steel (see § 3.6.1 and 3.6.2).

b. When, for the assessment or the redesign, the contribution of the infill walls in the resistance to seismic loads is taken into account, it is needed to investigate the mechanical characteristics of those walls as well (see § 3.7.3).

c. Finally, other type of materials may be present as part of the structure (e.g. steel or wood) or materials from previous intervention works (jackets, epoxy resins, fiber reinforced polymers, etc.), whose characteristics must be investigated.

3.5.4 Foundation Soil

a. When the geotechnical investigation that was considered for the construction of the building is available and no indication of failure of the foundation exists, a new geotechnical investigation

See also related § 2.1.4.2.

Particular attention is required in cases that there is suspicion of failure of the foundation of the existing building.

is not needed.

In other cases, the requirements of the following Table 3.1 are applied.

Table 3.1

Geotechnical investigation	Previous behavior of foundation	Intervention inducing additional loads to the soil	Need for new Geotechnical investigation
Available	bad		yes
Not Available	good	no	no
		yes	yes
	bad		yes

This provision applies regardless of whether the intervention induces additional actions on the ground or not.

A general knowledge of the soil is necessary for a classification according to EC8.

The support conditions of the structure to the ground are very important for the accuracy of the analysis of the superstructure.

Also, if for the assessment or redesign according to the provisions of Chapter 5, the soil – structure interaction is taken into account and if there is no sufficient geotechnical investigation (new or additional), a geotechnical investigation should be carried out according to the justified judgment of the Engineer.

- b. For buildings of importance class I and II (with $\gamma_I = 0.80$ or 1.00) in EC8 (Part 1, § 4.2.5, Table 4.3), the design values of soil parameters can be obtained from literature, according to the description of soil layers affected by the foundation.
- c. In cases where soil characteristics are not known by geotechnical investigation it is recommended to perform parametric analyses, using reasonable extreme values of soil deformability. The cases of

raft foundations or foundations consisting of grids of rigid foundation beams as well as cases of buildings with basements consisting of reinforced concrete perimeter walls are excluded.

3.5.5 Other factors

In special cases, the bearing capacity of the building may be affected by other factors, such as:

- The physical environment
- The vicinity of other buildings or underground structures
- The operation of machinery etc., that should therefore be evaluated.

3.6 DATA RELIABILITY LEVEL (DRL)

3.6.1 General

In existing structures, the numerical values of the data involved in the assessment and redesign may be subject to a larger error margin than in the case of new structures.

DRL is not defined by the dispersion of the results of the investigation works. The dispersion is already taken into account during the evaluation phase, and affects the “representative value” of every factor.

The concept of DRL is also applied for the completeness of the survey of the structure and infill walls, especially in case of hidden elements. The effects of uncertainties can be taken into account in actions or resistances depending on the

a. The reliability level of data (DRL) related to actions or resistances, signifies the adequacy of the information regarding the existing building and is taken into account in the assessment and redesign.

b. DRL is not necessarily the same for the entire building. Individual DRLs for the various sub-

case (e.g. uncertainty in the thickness of the flooring of the slab will be taken into account in actions; uncertainty in the thickness of the slab itself will be considered mainly in the resistances).

Regarding the self weight, the characteristic value considered must be the most unfavourable value that is compatible with the geometry of the structure and / or applies for such structures.

Regarding the resistances, their values can be determined from the dimensions, reinforcement and material characteristics that lead to the justification of prior behavior of the structure. So for example a strength value that corresponds to the ultimate resistance of a cross section for the existing acting loads can be used. Similarly, dimensions of inaccessible foundations can be estimated so that they correspond to an ultimate soil bearing capacity, etc.

Such may be the case for the representative values of some indirect actions (pressure or soil pressure) and the weight of inaccessible infill walls or coating / plastering.

In certain cases with increased doubt (and if it is considered that the influence of

categories of information can be determined. For the selection of the methods of analysis described in Chapter 5 the most unfavourable among the individual DRL shall be used (see § 5.7.2 and § 5.8.1).

3.6.2 DRL Categories

Three Levels of Data Reliability are distinguished:

- i. “High”
- ii. “Sufficient”
- iii. “Tolerable”.

Secondary structural elements as defined in § 5.1.2, can be taken into account even with more insufficient data. In this case the same for “Tolerable” D.R.L apply.

The aforementioned DRLs correspond to knowledge levels (KL) 1 to 3 (Limited, Normal, Full) of EC8 (Part 3, §3.3).

3.6.3 Impact of DRL on the assessment and redesign

Depending on the reliability of the data:

- i. The appropriate safety factors γ_f for certain actions with uncertain values are selected, combined with the appropriate γ_{sd} (see § 4.2).

the magnitude of the corresponding action is significant), the consideration of two “reasonably extreme” representative values ($S_{k, \min}$, and $S_{k, \max}$) is recommended.

As material data are considered the dimensions and strengths of concrete and reinforcing steel, as well as the actual reinforcement detailing, anchoring, starter bars etc. that determine the resistances.

- ii. The appropriate safety factors γ_m are selected according to the data for existing materials combined with the appropriate γ_{sd} (see § 4.2).

3.6.4 Criteria for the determination of the DRL

- a. The DRL for every data item will be treated with corresponding provisions which control the design of the relevant structural element.
- b. The DRL for the mechanical characteristics of materials, is determined as indicated in § 3.7, and especially in § 3.7.1.3 for concrete, in § 3.7.2.1 for reinforcing steel, in § 3.7.2.2 for prestressing steel, and in § 3.7 .3 for infill walls.
- c. The DRL for the geometric data of the structure is related to the data origin, and is defined according to Table 3.2 at the end of this chapter.

3.7 MINIMUM REQUIREMENTS FOR INVESTIGATION OF MATERIAL CHARACTERISTICS - EVALUATION OF RESULTS - DEFINITION OF DRLs

3.7.1 Concrete

3.7.1.1 General

- a. The investigation of concrete aims mainly to determine the

Other properties, such as modulus of elasticity, tensile

strength etc. can be determined indirectly (based on the compressive strength), if no specific investigation is conducted.

Such critical regions are the two ends of linear elements (columns and beams) and the area immediately above the base of shear walls. In the case of short columns, the entire height of the column is considered a critical region. It is possible that there are significant differences in strength between slabs, beams, upper and lower parts of columns (by a totally indicative ratio of 0.70 / 0.80 / 0.90 / 1.00), while in case of poor workmanship in column concreting it cannot be ruled out that the lower part may also develop lower strength due to segregation and cavitations.

Thus, for example, the measurements specified in § 3.7.1.1.e at the upper ends of columns may be made in a reasonable proportion of such positions (see § 3.7.1.1.f and 3.7.1.3.b), with their results applied to all the upper ends of the columns of the floor. In areas of poor workmanship the concrete strengths must not be considered equal to the ones determined in healthy regions. If it is deemed necessary the local values of concrete strength must be checked.

compressive strength for each area of the structure.

- b. For the assessment and redesign of an existing structure, the in-situ strength of concrete will be used in each critical region of every structural element.
- c. The expected systematic differentiation of concrete strength must be taken into account, depending on its characteristic position in the structure, and the conditions of concreting, compaction and maintenance.
- d. When there are no local indications of poor workmanship, the concrete strength values used in calculations for every characteristic position in the structure (see § c above), may be derived from measurements made at a selected percentage of all such positions in the building.
- e. The estimation of concrete strength in every critical region of structural elements is made with reliable indirect (non-destructive) methods, the field calibration of which must be

carried out as specified in § 3.7.1.2.c.

- f. The number of characteristic positions per floor and structural element type for which such measurements are made must be sufficient for the desired reliability, and it is also affected by the size of the position-to-position difference of the observed values. However, this number can not be less than the minimum requirements of § 3.7.1.3.a.

3.7.1.2. Methods for estimation of strength

- a. A combination of indirect methods and core sampling shall be made to enable control in more positions, with greater reliability.
- b. The conversion of core strength in the real in-situ strength is made through correction factors, which consider:
 - The height to diameter ratio of the core
 - The diameter of the core
 - The thickness of the element from which the core was taken
 - The disturbance caused by core sampling.

Limiting the number of cores reduces the wounds from the core sampling, while the application of indirect methods in more positions (by widening the extent of the investigation) leads to relatively lower costs.

To convert the strength of cores, draft Standard ELOT 344 may be used, with appropriate adaptation to the needs of the design if required. It is clarified that through such core sampling is not scientifically possible to estimate the nominal concrete strength of the whole building at the time of its construction.

Using indirect methods, the compressive strength of concrete is estimated indirectly by correlation with some other property (e.g. surface hardness, density, etc.). For example, curves are available in Greek literature for ultrasonic and rebound hammer methods that relate the readings with the compressive strength of concrete. Due to the large scatter, the curves can not be applied directly without prior calibration, based on which a new correlation curve must be compiled. For this purpose the following procedure may be applied:

- The mean value of strength for each group of cores is determined.
- The mean value of the measurements of the indirect methods in the corresponding core sampling positions is determined.
- Based on the above, a new correlation curve is determined, which is defined locally parallel to the curves available in the literature for the corresponding range of strength values.

If necessary, information may be retrieved from the project Dossier, such as:

- The design of the building
- The checks during construction
- Any concrete strength tests after construction (e.g. through cores sampling).

The strength of the cores is used for the calibration of indirect methods. The direct estimation of on the in-situ resistance of each structural element exclusively through

- c. Because the accuracy of indirect methods depends on many local factors, parallel core sampling is necessary in order to calibrate these methods in regard to the considered structure.

- d. Based on the results of the aforementioned tests, the designer Engineer is required to justify the assumptions about the characteristics of the concrete that will be used in the assessment and redesign, taking also into consideration any other available information.

3.7.1.3 Required number of tests – DRL

- a. For small (up to two-storey) buildings, the absolutely minimum required number of cores is $n = 3$, from structural elements of the same type. For larger buildings, at least 3 cores per two floors are required, but at least 3 cores in the “critical” floor.

cores would require a large number of tests, sufficient for statistical analysis of the results, taking also into account § 3.7.1.1.c.

The critical floor is considered to be the one for which the worst stress due to earthquake is expected. In normal cases the critical floor is the lower (ground) floor, especially in cases of a pilotis.

As indirect method, at least one of the ultrasonic or rebound hammer (or bolt pull out when $f_c < 15\text{MPa}$) methods shall be applied. A combination of methods is recommended. The linear elements (columns or beams) will be tested in at least two positions, at their ends. Walls are tested in at least one position at their base, per floor, see also § 3.7.1.1.a.

- b. In order for the DRL for concrete strength to be considered “high”, the positions of application of indirect methods must cover a sufficient percentage of each structural element type for every floor and in particular:
- 45% of vertical elements
 - 25% of horizontal elements (beams or slabs).

c. In order for the DRL to be considered “satisfactory” it is sufficient that the positions of application of indirect methods to cover a smaller but adequate percentage of each type of structural element and in particular:

- 30% of vertical elements
- 15% of horizontal elements (beams or slabs).

If the results of the measurements present a satisfactory convergence (i.e. a standard

deviation $S \leq 0,20 \bar{X}$), then the DRL can be considered “high”.

- d. By applying the method to half the percentages mentioned above in subsection (c), DRL can be considered “tolerable”, unless the results of the measurements present a satisfactory

Information is considered trustworthy and reliable when:

- The Design Dossier that has been actually executed in practice is available,
- Evidence of continuous supervision is available,
- Results of concrete specimen tests during construction are available.

For the visual identification / classification of reinforcement steel, exposure of reinforcement is required to the extent that is necessary according to the designer Engineer's judgment.

With respect to the class of reinforcement, in most cases relative uniformity is expected in a building, while there are many cases (especially during the period 1970~1985) where two classes of steel are applied in the same building, but usually in separate groups of structural elements.

To associate the steel class with the construction time as well as the form of ribs, relevant information is provided in the Greek STEEL TECHNOLOGY STANDARD (2008).

In those cases where for the check of the behaviour of structural elements, other characteristics are used than

convergence (i.e. a standard deviation $S \leq 0,20 \bar{X}$), so that the DRL can be considered "satisfactory".

- e. In special cases of buildings for which trustworthy and reliable information is available on their way of construction, the tests to verify the available information may be limited to the minimum core sampling indicated in the above paragraph (a), from elements of the same type of each floor. A required condition is the sufficient convergence of the results (i.e. the deviation of strength for each core is less than 15% of the mean value). For these cases the DRL is considered "satisfactory". However it is possible if the tests of subsection (c) are executed, then the DRL is considered "high". If the convergence of the results of core sampling is not satisfactory, then the above §§ b, c, d must be applied.

3.7.2 Steel

3.7.2.1 Reinforcing steel

- a. The determination of the class of the reinforcing steel of an existing building is a necessary condition for the assessment and redesign. The classification of steel can be done by visual identification (surface smooth or ribbed, any readable markings on the surface of the bars), in combination with the time of construction of the building. In this case DRL for the strength of steel is considered "satisfactory".
- b. The mechanical characteristics of steel that will be used to check the behaviour of structural elements may be taken as specified in the appropriate Standards for the category of

those specified for the steel class, special attention should be given to the requirements for anchorage lengths, lap lengths etc. (cf. § 3.5.2).

The expected difference in the characteristics of steel depending on the diameter of the bar, and the reduced ductility of highly corroded steel, must be taken into account conservatively.

For the “weldability” information is provided in the Greek STEEL TECHNOLOGY STANDARD (2008).

In the cases where the type of tendons of the specific prestressing system corresponds to potentially different steel classes, the investigation should be expanded. If sampling for testing the steel strength is not possible, parametric analyses should be performed for the different classes of strength.

steel identified in subsection (a) above.

In case of doubt about the reliability of steel classification through visual identification, the characteristics derived from appropriate investigation shall be used, as indicated in subsection (c) below.

- c. The investigation for the determination of the “actual” characteristics of steel (yield strength, ultimate strength, ductility) must include testing on at least three (3) samples of approximately the same diameter from structural elements of the critical floor.
If these samples reveal the presence of steel of different classes, then the investigation should be expanded to identify in which structural elements each different class has been placed. Only in this case the DRL for the strength of steel will be considered “high”.
- d. When welding of new and old reinforcements is specified for the redesign, an investigation should be conducted about their “weldability”.

3.7.2.2 *Prestressing steel*

- a. When the approved design is available, and during the survey stage (§ 3.2) it is found that this design has actually been implemented, the investigation may be limited to:
 - The recognition of the prestressing system
 - The confirmation of the number of tendons
 - The inspection of the “state” of tendons and anchorages.
- b. In the cases where there is insufficient information, systematic investigation is required for:
 - The recognition of the prestressing system and the type of tendons and anchorages

- The identification of the number of tendons and their layout
 - The investigation of the “state” of tendons and anchorages.
- c. For the determination of the prestressing steel class, its durability and choice of DRL, § 3.7.2.1 is applicable in general.

3.7.3 Infill walls

Regarding infill walls, and the cases where they are taken into account in resistance to seismic actions, the following are foreseen:

a. Surveying works include exposing masonry wall at (at least) two locations on each floor, with exposed area approximately 0.7x0.7m.

When surveying the following information is collected regarding:

- i. The system and the quality of construction
- ii. The thickness of the wall
- iii. The type and quality of building materials (bricks and mortar)
- iv. The thickness of the joints and the degree of filling with mortar, for both horizontal and vertical joints
- v. The wedging of masonry at the perimeter
- vi. Bed joints or bond beams (of any kind).

b. In order to determine the behaviour of masonry, compressive strength, shear strength and the corresponding moduli are of interest. When more precise data are not available, the above properties

The number and the type of tests will be according to the designer Engineer's judgment.

As geometric data the following are considered:

- The type and the geometry of the foundation structure,
- The type and the geometry of the superstructure,
- The type and the geometry of infill walls,
- Covering, coating, etc.
- Reinforcement layout.

can be determined indirectly by semi-empirical relations, based on individual characteristics such as brick strength, mortar strength, thickness of the joints, thickness and durability of the coating etc., as indicated in § 7.4.

In this case the DRL for the mechanical characteristics of masonry is considered “satisfactory” while a “tolerable” DRL is not allowed.

- c. When the mechanical characteristics of masonry are derived from investigation and in-situ and / or laboratory testing of a sufficient number of samples, the DRL can be considered “high”.

3.7.4 Geometrical data reliability level

Regarding the geometric data of the structure, the DRL depends on the origin of the data and varies according to each case, as indicated in the following Table 3.2.

TABLE 3.2: GEOMETRICAL DATA RELIABILITY LEVEL

ORIGINAL DESIGN DRAWINGS		DATA ORIGIN	NOTES	DATA										
				TYPE AND GEOMETRY OF FOUNDATION OR SUPERSTRUCTURE			THICKNESS, WEIGHT etc. OF INFILL WALLS, COATING, COVERING etc.			REINFORCEMENT LAYOUT AND DETAILING				
EXISTING	NON EXISTING			Tolerable	Satisfactory	High	Tolerable	Satisfactory	High	Tolerable	Satisfactory	High		
✓		1	Data that is derived from a drawing of the original design that is proved to have been applied without modification	(1)			✓			✓				✓
✓		2	Data that is derived from a drawing of the original design that has been applied with few modifications	(2)			✓			✓			✓	
✓		3	Data that is derived from a reference (e.g. legend in a drawing of the original design)	(3)	✓				✓			✓		
	✓	4	Data that has been determined and/or measured and/or surveyed reliably	(4)		✓				✓			✓	
	✓	5	Data that has been determined by an indirect but sufficiently reliable manner	(5)	✓				✓			✓		

	✓	6	Data that has been reasonably assumed using the Engineer's judgment	(6)	✓	✓		✓	✓		✓	✓	
--	---	---	---	-----	---	---	--	---	---	--	---	---	--

Notes on Table 3.2:

- (1) Complete drawings of the original design that were used for construction or “as built” drawings are available. During the investigation a sample verification of the implementation of the drawings was conducted, which revealed that the original design has practically been faithfully implemented. Regarding the reinforcement, the sample verification includes at least exposure of the reinforcement in 10% of the vertical elements per floor, and generally in at least one vertical element. This percentage (10%) can be reduced in case of uniformity. Indirect non-destructive methods may be used for the determination of the reinforcement; however, these methods do not substitute the direct investigation of the reinforcement through exposure.

Full drawings of the original design are considered:

- For the type and geometry of the structure at its foundation and superstructure, detailed drawings of structure dimensions should be present.
- For the type and the geometry of infill walls, as well as the self weight of covering and coating etc., complete architectural design with details of covering, coating etc should be present.
- For the reinforcement, bar bending schedules or reinforcement constructional details should be present.
- For each of the individual reinforcement data (reinforcement layout, diameter and number of bars, anchorage lengths, lap lengths and starter bar lengths, detailing and closing of stirrups etc.), a relevant drawing (reinforcement layout drawing etc.) should be present.

The same applies in case the drawings of the original design underwent very limited (and insignificant) changes.

- (2) Complete drawings of the original design are available. During construction of the project, limited modifications were made. These changes were detected, fully surveyed and the drawings were updated in a reliable manner. For the remainder, what is stated in (1) applies.
- (3) Independently on whether the original design has been applied (case 1) or not (case 2). For the remainder what is stated in (1) or (2) apply, respectively.
- (4) Practically no drawings of the original design are available. Data are derived from investigation / survey (see § 3.2.b)
- (5) Data derived by an indirect but sufficiently reliable manner (e.g. in case of uniformity, symmetry, foundation dimensions that give ultimate capacity, provided that no failure has been observed in the foundation and/or soil, etc.).
- (6) May be applied for the cases not mentioned in the text of the present Standard. The Engineer’s judgment is considered reliably documented and justified. The classification of the DRL as merely tolerable or satisfactory is done according to the Engineer’s judgment.

CHAPTER 4

BASIC DATA FOR ASSESSMENT AND REDESIGN

4.1 THE RATIONALE OF THE VERIFICATIONS, THE SAFETY INEQUALITY

4.1.1 Safety verification

The safety verification, performed at an appropriate member or the whole structure, must prove that the imposed critical factor (in terms of forces or in terms of deformations) is reliably smaller than that available capacity.

The desired reliability is ensured by compliance with the provisions or the present Standard.

The inequality is general, and can involve forces or deformations or a combination of the two.

Thus, the safety inequality may concern the overall balance check of a structure as a whole (overturning and sliding), or the stability check, the crack width check, the deflection check or even the verification that an imposed top displacement of the structure is less than the corresponding available displacement (“resistance”) before failure.

Of course, the functions S (or E) and R involve the geometric data a_d .

4.1.2 Safety inequality

The safety inequality applied during the assessment and redesign of existing structures has the same general form also provided in the Eurocodes (EC):

$S_d < R_d$, with

$S_d = \gamma_{Sd} \cdot S (S_k \cdot \gamma_f)$ and

$R_d = (1/\gamma_{Rd}) \cdot R (R_k/\gamma_m)$,

where:

- S_d The design (and assessment) values of force or deformation measures that are caused by the imposed

Force terms ("forces") are the normal and shear forces (N and V) as well as the flexural and torsional moments (M and T) that strain structural elements (e.g. a node of a space frame) or interfaces in the case of repair/strengthening (e.g. between old and new materials or elements).

Deformation terms ("deformations") are all displacements (d), deflections, rotations (θ) of frame elements, angular deformations (γ) of shear walls or curvatures ($1/r$) that result from the imposed actions (e.g. imposed loads or indirect actions, namely imposed or constrained deformations)

For the representative values of actions S_k , generally the standard values are adopted and used, in accordance with current Standards, except for special cases at the discretion and approval of the Public Authority. In particular, for seismic actions see §§ 4.4.1.2 and 4.4.1.3.

For the "representative" values of the resistances R_k , in terms of forces or in terms of deformations, the following apply:

- Depending on the verification method, the type of failure and the type of the element which is checked (see §§ 4.1.3 and 4.1.4, and Ch. 9) the appropriate mean values, or other characteristic values are selected, with appropriate percentile probability
- In particular, the representative values for existing materials will depend on the data reliability level (see Chapter 3 and §4.2), while for added materials they will depend on the estimated

- actions
- R_d The design (and assessment) values of the available respective resistances (in terms of forces or in terms of deformations)
- S_k The representative values of basic and accidental actions, for which there is a certain probability of exceedance in 50 years
- R_k The representative values of material properties that determine the values of resistances and have a certain probability of exceedance

deviations from uniformity during the implementation of interventions (see Chapter 8), i.e. they will depend on the size of the added cross-section and the accessibility of the area of the intervention.

Generally coefficients γ_f are elected according to the provisions of the Eurocodes.

For coefficients γ_m see §4.5.3.

For new buildings, these coefficients are not presented individually but are incorporated into γ_f (γ_g or γ_q) and γ_m (γ_c or γ_s).

For the assessment of existing buildings, some models (Chapters 5 through 9) include uncertainties in the mathematical expression of the corresponding natural phenomena, which must be compensated by the appropriate safety factors γ_{Sd} and γ_{Rd} against those model uncertainties.

In some cases, a hypersensitivity of the model against the change of values of certain parameters may be observed, accompanied with a disproportionate differentiation of the final result.

In these cases, a “sensitivity analysis” may be required, aiming to design (or model) changes in order to limit this hypersensitivity.

The reduction of the adverse consequences of some uncertainties in the assessment and redesign process is the aim of the provisions regarding maxima/minima, in correspondence of what applies to the design of new buildings, for example See Chapters 6 to 8.

- γ_f, γ_m The partial safety factors for actions and material properties through which the possible unfavourable deviations of the corresponding variables from their representative values are taken into account
- γ_{Sd}, γ_{Rd} The partial safety factors which take into account the increased (compared to the design of new buildings) uncertainties of the models, through which the effects of actions and all types of resistances are assessed respectively (see also Chapter 2, §§2.4.3 and 2.4.4.).

Finally, the safety inequality is verified according to the special provisions presented in detail in Chapter 9, depending also on the performance level (see Chapter 2).

4.1.3 Application of linear analysis methods

In the case of application of linear analysis methods (see Chapter 5), the verifications and the safety inequality are applied according to the Eurocodes, and more particularly according to the provisions of the present Standard while generally the verifications are performed in terms of internal forces.

4.1.4 Application of non-linear analysis methods

In particular, in the case of application non-linear methods (§5.7, §5.8), the following apply:

- i) In this case, the safety verification is the comparison of the maximum available and target response of the “top” of the structure in terms of forces and deformations against the requirements of the range of forces / deformations corresponding to the seismic action adopted for the assessment.
- ii) The representative values and the partial safety factors for the material properties or the reliability of the model depend on the nature of the critical factor under verification and the type of failure (quasi-brittle or quasi-ductile) as defined in §§4.4 and 4.5, and Chapter 9.
- iii) The choice of the category of verification methods, in terms of forces or deformations, is based on the anticipated failure type (brittle or ductile).

By convention, if the available local ductility μ_{θ} (or μ_d) is \geq

In general non-linear analysis methods are applied for performance levels B or C.

Regarding the “top” of the structure (the “control node”) see Chapter 5 (§5.7.3.2).

For response spectra see §4.4.1.3.

See also §7.1.2.6.

As a simplification, verification of normal forces (M and N) are

made in terms of deformations.

In any case, possible brittle failure mechanisms (e.g. due to shear or due to a small shear ratio, $\alpha_s < 2$) are verified in terms of forces.

Also, basement and foundation elements are always verified in terms of (internal) forces.

In Chapters 2 and 3, criteria of characterization of the reliability of these data in the documentation phase of the existing building are given.

Στον Φάκελο του Έργου (βλ. Κεφ. 10 και 11), θα υπάρχουν σαφείς αναφορές για τις στάθμες αξιοπιστίας δεδομένων που ελήφθησαν υπόψη στα διάφορα στάδια αποτίμησης και ανασχεδιασμού.

Clear references to the data reliability levels taken into account in the various stages of assessment and redesign shall be made in the project Dossier (see Chapters 10 and 11).

There is no point in the desired precision of any such method being higher than the expected inaccuracy of the data which will be used. Of course, parametric investigations and analyses, according to the comments on γ_{Sd} και γ_{Rd} of §4.1.2 can lead to more precise approaches.

Such may be the case of representative values of certain indirect actions, or pressures, as well as the weight of cladding, masonry etc in areas with difficult access.

In some cases where there are significant uncertainties, though it appears that the influence of the magnitude of the corresponding action is important, it is recommended to consider two “reasonably

2.0 (or if $\mu_{1/r} \geq 3.0$), i.e. if the behaviour is quasi-ductile, verification is made in terms of deformations. Otherwise, if the behaviour is quasi-brittle, verification is made in terms of forces.

4.2 DATA RELIABILITY LEVELS

- a) In existing structures, the numerical values of data involved in the assessment and redesign may be subject to more significant errors than in the case of new structures.

- b) Depending on the reliability of the data:
 - i) A generally appropriate method of analysis and reassessment is chosen according to Chapter 5.

 - ii) The appropriate safety factors γ_f are selected for certain actions with highly uncertain values, in combination with appropriate γ_{Sd} (see §§4.4 and 4.5).

extreme” representative values ($S_{k,min}$ and $S_{k,max}$), see also §4.5.2.

Material data or properties are the dimensions and strengths of concrete and reinforcing steel, but also the actual reinforcement details, anchorage, starter bars etc. that determine the resistances. The materials of infill walls and the way the latter were constructed are also considered, where and when it is necessary to or will be taken into account (see also §7.4).

See related §§4.4.3.d and 4.5.3.2.b.

Regarding the special issue of assessment and redesign based on test results, a reference is made to Eurocode ENV 1990, Clause 5.2 and Appendix D - Design assisted by testing.

The Public Authority, under certain conditions associated with data reliability levels, but also the intended performance level (see Chapter 2) and the future use of the structure can allow a modification of the nominal values of loads and / or partial factors

iii) The appropriate safety factors for the existing material properties, in combination with the appropriate γ_{Rd} (see §§4.4 and 4.5).

4.3 ADDITIONAL PROVISIONS

- a) In certain cases, at the discretion and approval of the Public Authority, the estimation of resistances R_d (not on material level but on the level of cross-section, region or element as a whole) is allowed through laboratory tests.
- b) In these cases, the adverse effects of the application conditions are taken particularly into account, as well as those factors which can not be reproduced during laboratory or other tests.

4.4 BASIC VARIABLES

4.4.1 Actions

4.4.1.1 Basic actions (non-seismic)

During the assessment and redesign all key actions, their potential synergy and required combination are taken into account (see §4.4.2).

Also, the partial safety factors γ_f (γ_g , γ_q) provided by

γ_f and ψ_i .

See also related §4.2.b(ii).

The increase of the seismic actions for the assessment through the coefficient γ_i , allows for the expansion of conventional life of the structure beyond the 50 year period, or (equivalently) to take into account the consequences of potential failure.

For the assessment and redesign of existing structures, simpler superposition rules of the components of the earthquake may be applied, according to Chapter 5 (see §5.4.9).

Other accidental actions are not considered in the assessment and redesign, except fire within the standing framework of Standards (e.g. Fire Code, OGG¹ 32/A/17.02.88 and other relevant resolutions, provisions etc.) depending on the use and risk level of the structure (as a whole or in part).

¹ Official Government Gazette

modern current Standards are take into account, with the exceptions mentioned in §4.5.2.

4.4.1.2 Accidental actions (earthquake)

The main accidental action, the earthquake, depends on the target of the assessment and redesign, according to Chapter 2, taking into account the importance factor γ_I of EC8 and (potentially) the damping correction factor η for materials of primary (lateral load resisting) members with a critical (viscous) damping ratio ξ not equal to 5% (see § 4.6.3.g).

For a 10% probability of exceedance within the reference 50-year period, the seismic action of EC8 is taken into account while for a 50% probability of exceedance within the reference 50-year period, 60% of the seismic action of EC8 is taken into account.

A Public Authority shall define the cases where a 50% probability of exceedance within the reference 50-year period will not be allowed.

The damping ratio ζ varies with the material of the primary (lateral load resisting) members of the building.

I.e. for $\gamma_I \alpha T_C \leq T \leq T_D$ the following expression is used:

$$S_d(T) = \gamma_I \cdot a_{gR} \cdot S \cdot (2.5/q) \cdot (T_C/T) .$$

I.e. for $\gamma_I \alpha T_C \leq T \leq T_D$ the following expression is used:

$$S_e(T) = \gamma_I \cdot a_{gR} \cdot S \cdot n \cdot 2.5 \cdot (T_C/T) .$$

The shear and axial stiffnesses of structural elements shall be estimated according to classical mechanics.

Thus for reinforced concrete buildings the use of values $0.4E_cA_w$ and E_cA_g , respectively, is allowed where:

- A_g = the total cross section of the member (concrete only)
- A_w = only the (rectangular) cross section of the web of the member (e.g. for T-beams).

4.4.1.3 Response Spectra

Generally, the acceleration response spectra of EC8 are used, as a function of the building's period T and the critical (viscous) damping ratio ξ or behaviour factor q .

In case of application of linear analysis methods, the modified "design spectra" $S_d(T)$ are used.

In case of application of non-linear analysis methods, the normalized "elastic spectra" $S_e(T)$ are used.

4.4.1.4 Stiffnesses

In any case, the stiffness will be estimated based on the actual characteristics of the structural element and its earthquake strain, using mean values of material properties (without coefficients γ_m).

Generally, the secant stiffness at yielding of the structural element will be used, which is estimated as described in the following Chapters 7 and 8.

In the absence of more precise data, the stiffness values of the following table can be used.

Table S 4.1: Stiffness values

No.	Structural element	Δυσκαμψία
1.1	Column, internal	$0,8*(E_c I_g)$
1.2	Column, perimeter	$0,6*(E_c I_g)$
2.1	Shear wall, uncracked	$0,7*(E_c I_g)$
2.2	Shear wall, cracked (1)	$0,5*(E_c I_g)$
3	Beam (2)	$0,4*(E_c I_g)$

- (1) Or repaired, with basic methods.
- (2) For L- and T-beams it is allowed to assume $I_g = (1.5 \text{ or } 2.0)I_w$, respectively, where I_w is the moment of inertia of the rectangular web only.

Indirect actions are generally not considered, especially for ultimate limit states.

During the assessment and redesign against earthquake, issues of serviceability or durability are not addressed, especially for existing structural components that do not present related problems.

Of course, for any new components (or for repaired ones, after the interventions), all the modern perceptions and provisions for serviceability (e.g. limitation of deflections and cracking) and

In case of application of linear methods, using a uniform behaviour factor q , or local ductility ratios m , when the verifications are generally in terms of forces, the stiffness can be estimated as a percentage of stage-I stiffness (uncracked elements).

4.4.2 Combinations of actions

Combinations of actions for ultimate limit states (basic and accidental combinations) as well as for service limit states shall be in accordance with modern current Standards and the relevant combination factors of variables actions ψ_i .

durability (e.g. minimum concrete covers) are observed.

If, in special cases, special verifications at service limit states are required, those are made using the standard values of partial safety factors γ_f and γ_m .

On how to estimate mean value and standard deviation, see Chapter 3, as well as Appendix 4.1.

In this case, safety factors for materials are taken according to §§4.5.3.1 and 4.5.3.2.

The calculation of stiffnesses is made according to § 4.4.1.4.

See also § 4.1.4.

In this case, material safety factors are almost equal to unity (§4.5.3.3).

The calculation of stiffnesses is made using mean values of material properties (without γ_m factors), see Chapters 7 and 8, as well as §4.4.1.4.

For example, an existing reinforced concrete building may be assessed and redesigned using representative values of material

4.4.3 Resistances

a) For the resistances of each structural element, the safety verification (see §4.1) is performed with material properties that generally depend on the nature of the critical factor under verification (forces or deformations):

- If the safety verification is made in terms of internal forces, the properties of existing materials of a specific (individual) structural element are generally represented as their mean values minus one standard deviation (or just their mean values, see Chapter 9), while properties of added materials are represented as their characteristic values provided by the relevant Standards.
- If the safety verification is made in terms of deformations (displacements, rotations etc.), material properties are generally represented as their mean values.

b) Assessment and redesign of existing structural elements using representative values of resistances (for concrete and

properties which have resulted from tests after appropriate calibration (see Chapter 3).

I.e., values such as $f_{ck} = 14.50 \text{ MPa}$ και $f_{yk} = 300 \text{ MPa}$, can be used, where the subscript « k » refers to the representative value (mean minus one standard deviation, or mean), which will be divided by the appropriate partial factor γ_m (§4.5.3) in order to estimate the “design value”.

In these cases, however, the respective efficiency (for instance) of bar anchorage (or splices) as well as the consequences of a potential reduction in ductility due to change of local conditions for capacity design must also be checked.

See §4.3, as well as §4.5.3.2.β.
Also, see Chapter 8.

Thus the “residual” deformation of the added material at failure is:

$$\varepsilon_{u,res} = \varepsilon_u - \varepsilon_o,$$

where ε_u according to Chapter 8
and $\varepsilon_o = t/2r$.

reinforcing steel) that do not coincide with the categories (classes) of materials defined in current Standards is allowed.

- c) Also, a conservative differentiation of representative values of yield and failure stress, or other characteristics of existing or added steel reinforcements in relation to bar diameter (e.g. increase of f_{sy} and f_{st} with reduction of the diameter) is allowed, but only when relatively reliable data are available.
- d) In particular, for added materials not covered by current Standards, the representative property values and variations will be determined by Ministerial Decrees according to the relevant Technical Approval procedures.
- e) The application of an additional (steel) sheet or fabric (FRP) in corners and edges of a structural element entails a local reduction, ε_o , of the available failure strain, ε_u , of the added component, depending on the local curvature radius, r , and thickness, t , of the added material.

4.5 PARTIAL SAFETY FACTORS

4.5.1 On models

Coefficients γ_{Rd} are given in Chapters 6 to 9, accordingly.

E.g. a percentage larger than 75%.
See related §4.6.3.a.

In the absence of more accurate data, γ_{Sd} values according to the following Table may be used.

Table S 4.2: Values of coefficient γ_{Sd}

Intense and extensive damage and/or interventions	Light and local damage and / or interventions	Without damage and without interventions
$\gamma_{Sd} = 1.20$	$\gamma_{Sd} = 1.10$	$\gamma_{Sd} = 1.00$

See also Appendix 7D on damage and decay.

- a) For analysis and behaviour models, as well as for the verifications, appropriate partial safety factors γ_{Sd} and γ_{Rd} are given in Chapters 5 to 9 (see §4.1), in order to reflect the increased uncertainties that accompany them.
- b) When almost all seismic actions are resisted mainly by new, adequate and efficient structures, then generally $\gamma_{Sd} = 1.00$.
- c) When seismic actions are also (or entirely) resisted by the existing structure and no parametric investigations and checks are made (in order to assess the potential sensitivity against change of value of certain parameters), γ_{Sd} values used depend on the severity (intensity) and the extent of damage and / or interventions (regardless of method of analysis).
- d) Also, according to Chapter 5, an elastic analysis, static or dynamic, may be applied only for assessment purposes, regardless of the satisfaction of the conditions of application (see §§5.5.2.b and 5.6.1.b) if coefficients γ_{Sd} given in the present paragraph §4.5.1 are increased by 0.15 (i.e. $\gamma_{Sd,el.} = \gamma_{Sd} + 0.15$).

4.5.2 On actions (ultimate limit states)

- a) For variable actions, generally the standard values of τιμές γ_f

In this framework, a value of $\gamma_g=1.35$ or 1.10 may be applied in combination with two “reasonably extreme” representative values $G_{k,min}$ and $G_{k,max}$, (see also §4.2.b.ii), e.g. in cases of tolerable DRL with increased dispersions, with the aim to reduce the number of the required measurements and checks.

This case also covers the – accidental – earthquake action (with $\gamma_g=1.10 \pm 0.10$).

See also Appendix 4.1.

When the representative value is equal to the mean, §4.5.3.3 applies.

Especially for concrete it is allowed to take into account in more detail the influence of the component of γ_m which expresses the relationship between the “in-situ” resistances compared to the strength of “conventional” samples taken before concrete laying

and ψ_i are used, according to the Standards.

b) Depending on the reliability level of the geometric data of the existing elements, values γ_g for permanent actions will be taken as follows:

- For basic combinations and for unfavourable influence of the action
 - Satisfactory DRL $\gamma_g = 1.35$
 - Tolerable or high DRL $\gamma_g = 1.50$ or 1.20 , respectively
- For other combinations and influence of the action
 - Satisfactory DRL $\gamma_g = 1.10$
 - Tolerable or high DRL $\gamma_g = 1.20$ or 1.00 , respectively

For new elements, new structures etc. generally standard γ_g values are used.

4.5.3 On material properties (ultimate limit states)

4.5.3.1 Existing materials

When the representative value is equal to the mean value minus one standard deviation (§4.4.3), the following apply:

according to the Standards, see also Chapter 3.

For “tolerable” or “high” data reliability level, γ_m values for non-reinforced infill walls may be taken equal to 2.50 or 1.50 respectively, while for “satisfactory” data reliability level $\gamma_m = 2.00$.

When the representative value is equal to the mean, then §4.5.3.3 applies.

- a) For a satisfactory data reliability level (see Chapter 3) γ_m values will be taken as foreseen by the current Standards.
- b) For tolerable data reliability level, γ_m values will be taken higher than the ones foreseen by current Standards.
In the absence of more accurate data, the following values may be used:
 $\gamma_c = 1.65$ and $\gamma_s = 1.25$
- c) For high data reliability level, γ_m values will be taken lower than the ones foreseen by current Standards.
In the absence of more accurate data, the following values may be used:
 $\gamma_c = 1.35$ and $\gamma_s = 1.05$
- d) When existing infill walls are taken into account for the assessment or redesign, then γ_m values will be determined depending on the data reliability level.

4.5.3.2 Added materials

When the representative value is equal to the characteristic (§4.4.3), the following apply:

In the absence of more accurate data, the values of the following Table may be used:

Table S 4.3: Values of the ratio γ'_m/γ_m for added “standard” materials (concrete or steel, according to the C.T.S.¹ and S.T.S.²)

Cross section of added materials and / or accessibility of the area of the intervention	
Normal (standard)	Reduced
1.05	1.20

For intermediate cases, intermediate values are allowed.

¹ Greek Concrete Technology Standard

² Greek Concrete Technology Standard

See §4.3. as well as §4.4.3.δ.

See also Chapter 8.

Such new materials for intervention are, for example, cement grouts

a) Added materials covered by current Standards.

For concrete and reinforcing steel, partial coefficients γ'_m which are generally larger than standard ones are used, in order to cater for any additional uncertainties related to (see also Chapter 8):

- The variety of technical interventions and the possibly small cross-section of the added new materials, and
- The difficulty of accessibility and inspection and the subsequent deviations of uniformity and quality.

b) Added materials not covered by current Standards

For the determination of the values of safety

(including shotcrete and fiber reinforced), fiber reinforced polymers, laminates, fabrics, sheets, adhesives (epoxy resin + hardener) etc.

In chapter 8 the applicable values γ_m for each case are given.

Particularly, when these materials are applied in unusually small (or large) lengths or cross sections for their type, or under conditions of poor accessibility (and control), an appropriate increase of γ_m values is required.

Depending on construction quality and quality control of the manufacturer facility, γ_m values may range from 1.7 to 3.0 (see also EC6).

See also Appendix 4.1

For “satisfactory” data reliability level and if the standard deviation of individual values is relatively small, $\gamma_m=1.00$ may be taken for existing materials.

However, practically it is recommended to use $\gamma_m =1.10$.

factors for added special materials on interventions, the available experience of use of such materials will be taken into account, as well as the additional uncertainties referenced in the preceding paragraph for ordinary materials, according to the Engineer’s judgment.

- c) For added infill walls, without or with interspersed reinforcement or light jackets (see Chapter 8), γ_m values according to current Standards apply.

4.5.3.3 Mean values of material properties

When “mean” values of material properties are used for the calculation of resistances, then γ_m values which are in principle approximately equal to unity are increased appropriately in order to take into account geometric uncertainties (for existing materials) or difficulties in achieving and verifying nominal strengths in-situ (for added materials).

For “high” or “tolerable” data reliability level, γ_m values may be taken equal to 1.00 or 1.20, respectively.

For added materials, $\gamma_m=1.15$ may be used for normal (ordinary) cross section and accessibility, or $\gamma_m=1.25$ for smaller cross section or limited accessibility, regardless of whether the materials are covered by Standards or not.

4.6 UNIFORM BEHAVIOUR FACTOR q

4.6.1 General

The methodology for the assessment of the available uniform behaviour factor differs depending on whether the existing structure exhibits damage (and wear) or not, as well as on whether or not it has been designed according to modern Standards incorporating the behaviour factor logic.

The methodology of the assessment of the behaviour factor as the product of the overstrength (q_u) and ductility (q_π) factors, i.e. $q=q_u \cdot q_\pi$, is presented in Appendix 4.2.

See also Appendix 4.3.

- a) During the assessment and redesign procedure, when a uniform behaviour factor for the entire structure is used according to the provisions of Chapter 5, its value will be estimated taking into account the factors that have participated in the seismic energy consumption, as set out in the next §4.6.2.

For the purposes of the present Standard, conservative approaches may be adopted for the assessment of the factors involved in the modulation of a uniform behaviour factor.

- b) Depending on the intended performance level for the assessment and redesign of the structure (Chapter 2), modified values q^* which are given in the Table below are used, with reference value q the one for performance level B (life protection), which corresponds to the rules and provisions of EC8 for the design of new buildings.

Values q_A/q_B and q_Γ/q_B depend on the behaviour of the building. Thus, for more brittle systems (with lower q values) the ratio q^*/q' has values of the order of 0.8 or 1.2 for performance levels A and C respectively, while for more ductile systems (with larger q values) the ratio q^*/q' has values of the order of 0.4 or 1.6 for performance levels A and C, respectively.

The values in Table 4.1 shall apply regardless of the possibility of exceedance of the design earthquake (generally 10% or 50% - at the discretion and approval of the Public Authority), see also § 4.4.1.2.

Certainly, the probability of exceedance (during the conventional 50 years), affects the size of the seismic action directly, see (also) §4.4.1.2 and Appendix 4.3.

Thus, when the method of the uniform (global) behaviour factor q is applied, its value is allowed to be increased by 25% compared to the values given below (see also Chapter 9, §9.1.3.c).

Table 4.1 : Values of q^*/q' ratio depending on the target of the assessment of the structure

Performance level		
Immediate use after the earthquake (A)	Life protection (B)	Collapse prevention (Γ)
0,6 with $1.0 < q^* < 1.5$	1.0	1.4

However, for performance level A the final value of the behaviour factor is just over 1.0 and in any case lower than 1.5.

c) For buildings for which the influence of higher modes is important, it is recommended to employ non-linear static analysis in combination with elastic dynamic analysis, thus

performing all the verifications according to both methods, see §5.7.2.b, while an increase by 25% of the values of the parameters involved in the criteria of the verifications is allowed.

4.6.2 Assessment

The factors involved in determining q as presented in this Text, but also in Appendix 4.2, are valid for both new and existing buildings under assessment (or redesign)

The uniform behaviour factor differs depending also on whether the building has or has not been designed for earthquake using the behaviour factor rationale.

Substantial damage (and wear) is considered that, that has led to a bearing capacity reduction larger than 25% ($r_R \leq 0.75$), see also Appendix 7D.

For example, a pilotis is considered to be (and generally is) a “soft” or “weak” story.

During the phase of the assessment of the building, the value q' shall be selected taking the following into account:

- The efficiency of the Standards during the era of the design and construction of the building
- The potential existence of substantial damage (and wear), mainly in primary structural elements
- The uniformity of distribution of overstrength within a story and between stories (along the height of the building), and the degree of prevention of the formation of a “soft” story.
- The number of structural elements in which plastic hinges are expected to form, which depends on the degree of the static indeterminacy and the regularity of the structure
- The prioritization of the occurrence of failures and the extent of their prevention in primary vertical load bearing elements and nodes

- The modes of failure (ductile or brittle)
- The available local ductility in critical regions of each structural element, and
- The available auxiliary mechanisms of seismic behaviour such as infill walls, diaphragms etc.

In the absence of more detailed data, it is allowed to apply (as maxima) the values of the following Table, depending on the level of damage and the effect of infill walls (for the entire building).

Table S 4.4 : Values of behaviour factor q' for performance level B (life protection)

Standards applied for design (and construction)	Favourable presence or absence of infill walls (1)		Generally unfavourable presence of infill walls (1)	
	Substantial damage in primary elements		Substantial damage in primary elements	
	No	Yes	No	Yes
1995<...	3.0	2.3	2.3	1.7
1985<...<1995(2)	2.3	1.7	1.7	1.3
...<1985	1.7	1.3	1.3	1.1

(1) On the role and effect of infill walls see §5.9 και §7.4.

(2) For buildings of this period, the values of the Table are valid provided that the check for non-formation of plastic hinges in column ends is made according to §9.3.3 (by satisfying $\Sigma M_{Rc} \geq 1,3 \Sigma M_{Rb}$).

For torsionally sensitive structures, or for those with at least 50% of the mass concentrated in the upper 1/3 of their height (inverted pendula), the values of the Table are multiplied by 2/3 but can not be lower than 1.0.

The adequacy of the new “frame” (against earthquake), according to this paragraph shall be judged on the basis of the number and arrangement of the new elements, their V_R / V_S ratios and the adequacy of their foundation and connection to the existing structure. In the absence of more accurate data, the new or final “frame” will

4.6.3 Redesign

- a) When laying out new strong elements (adequate in terms of number and resistance) or when upgrading / modifying existing elements (new “frame”), the corresponding q values of current Standards may be used (i.e. $q'=q$), in combination with the corresponding sets of individual criteria, provisions

be sufficient if (see also § 4.5.1.b):

- a) There are at least two non - coplanar and uniform (along the height of the building – generally ‘shear walls’ or additional frames) in two directions perpendicular to each other (e.g. the primary ones) depending on the size, geometry and regularity of the structure.
- b) The ratio V_R / V_S for all these new elements is at least 0.75 on each floor and in every direction, where V_R is the total shear force resisted by new elements ($\Sigma V_{Rd,s,i}$) where V_S is the acting shear force.
In cases where $0.60 \leq V_R / V_S \leq 0.75$, values $q = 4/5q$ may be used provided that a $\gamma_{sd}=1.10$ factor is taken into account (see §4.5.1.b).
- c) A check of the connection of the new elements with the existing structure is made, to ensure that their response is quasi-elastic, and finally
- d) A check of the foundations is made (in combination with the existing footings), to ensure that their response are also quasi-elastic for the design earthquake.

The previous requirements “c” and “d” shall be considered to be met when the design of the connections and foundations is made for internal forces increased by $\gamma_{sd} = 1,35 (\leq q^*)$.

For example, a building constructed in 1980 with substantial damage and unfavourable presence of infill walls on a large scale (i.e. presence of many “short” columns) may be assessed according

etc. for the design of new structures (depending on ductility class as per EC8). More details (as well as additional provisions) are given in § 8.5 for the cases where the addition of truss elements made of structural steel is deemed necessary.

- b) In cases of “mild” yet extensive interventions, e.g. simple but widespread repairs of major (and minor) damage of primary (lateral load resisting) but also all other elements

to Table S4.4 for $q'_{(B)} \cong 1.1$, but redesigned for $q'_{(B)} \cong 1.3$ or 1.7 , simply if damage is repaired or if the favourable presence of full infill walls on a large scale is also ensured, respectively.

Also, a building constructed in 1990 with substantial damage and unfavourable presence of presence of infill walls on a large scale (i.e. presence of many “short” columns) may be assessed according to Table S4.4 for $q'_{(B)} \cong 1.3$, but redesigned for $q'_{(B)} \cong 1.7$ or 2.3 , simply if damage is repaired or if the unfavourable local effects of infill walls are also lifted, (e.g. building-covering of scuttles or laying out of many strong full panels), respectively.

See related §4.4.1.2.

(so that their mechanical characteristics are restored), and / or when laying out new (or upgrading the existing) strong infill walls in the entire building with reliably favourable and positive effect, larger q' values, compared to the ones used for the assessment, may be used.

- c) In any case, for the redesign (or also the assessment, see §4.6.2), the appropriate value of the critical (viscous) damping ratio ξ is taken into account for the material of the primary (lateral load resisting) elements, via the correction factor (η according to EC8).

4.7 LOCAL DUCTILITY FACTORS m

4.7.1 General

A classification of elements is made into structural (primary and secondary) and non-structural elements (mainly infills, existing or added, which are treated as especial elements under earthquake), see Chapter 2.

In Chapters 7 and 8 the values of the m factors ($m=d_d/d_y=\theta_d/\theta_y$) are defined, depending on the desired structural performance level and the available ductility of individual structural elements.

The available local ductility at critical sections of structural members is estimated by means of the m factors, according to Chapters 7 and 8.

Through local m factors, the corresponding uniform behavior factor q can be estimated based on the methodology of Appendix 4.2

For the structural performance levels and local m factors, as well as for the corresponding uniform q factor (see § 4.6.1), see Appendix 4.4.

I.e. $F_d \leq F_y$ and $d_d \leq d_y$ or $\theta_d \leq \theta_y$ (so $m \cong 1.00$), with $\gamma_{Rd} = 1$.

Similarly, $1.0 < q < 1.5$, see also Table 4.1.

The classification of structural elements into primary and secondary it is not allowed for performance level (A) (see § 2.4.3.4).

For primary elements: $d_d \cong 0.50(d_y + d_u) / \gamma_{Rd}$.

For secondary elements: $d_d \cong d_u / \gamma_{Rd}$

For infill walls: $d_d \cong d_u / \gamma_{Rd}$

For primary elements: $d_d \cong d_u / \gamma_{Rd}$.

For secondary elements: $d_d \cong d_u$, with $\gamma_{Rd} = 1$.

For infill walls: $d_d \cong d_u$, with $\gamma_{Rd} = 1$.

The values of the local m factors should be chosen and calibrated so that the value of the corresponding uniform behavior factor for the whole structure does not deviate by more than 15% than the value according to § 4.6, see also § 2.4.5.

For performance level (A) "Immediate occupancy after the earthquake" the structure (and its infills) is expected to have an almost quasi-elastic behaviour and not to develop post-elastic deformations (almost at any component) or severe damage.

For the intermediate performance level (B), "Life Protection", the structure is allowed to develop significant and extensive post-elastic deformations, although it must have adequate and reliable margins against potential exhaustion of its available deformation capacity.

For performance level (C), "Collapse Prevention", the structure develops large post-elastic deformations and may even reach the available deformation capacity for many components, of course without collapsing under gravity loads.

In case of buildings where the influence of higher modes is important, it is recommended to perform inelastic static analysis in combination with elastic dynamic analysis, and all verifications to be performed using both methods, while it is also allowed to increase the values of m factors involved in the above verifications by 25%, see Chapter 5, §5.7.2.b, & Chapter 9, § 9.1.3.c.

4.7.2 Assessment

For existing members, with or without damage, the m factors should be evaluated using the methods included in Chapter 7.

4.7.3 Redesign

For existing members after interventions, as well as for hybrid or composite members, the m factors should be evaluated based on the methods of Chapter 8, while for purely new (added) members the m factors should be evaluated using the methods of Chapter 7.

4.8 Seismic Interaction of adjacent buildings

In cases where the distance between adjacent buildings is smaller than the width of the required seismic joint (complete separation), as defined in EC8, the following are recommended:

a) When all slabs of the adjacent buildings are located

4.8.1 It is recommended that the adverse possibility of the building pounding with adjacent buildings due to their out-of-phase movement is taken into account as optimally as it is practically feasible.

approximately at the same levels, i.e. when there is no chance of floor-column pounding, it is generally not necessary to take special measures against pounding.

Two slabs are considered to be almost on the same level when for a length equal to at least two thirds of the common length of the buildings, their levels differ by less than two thirds of the transverse dimension of the column (or shear wall) or the height of the deepest beam perpendicular or parallel to the common wall – whichever of the two categories is more favourable.

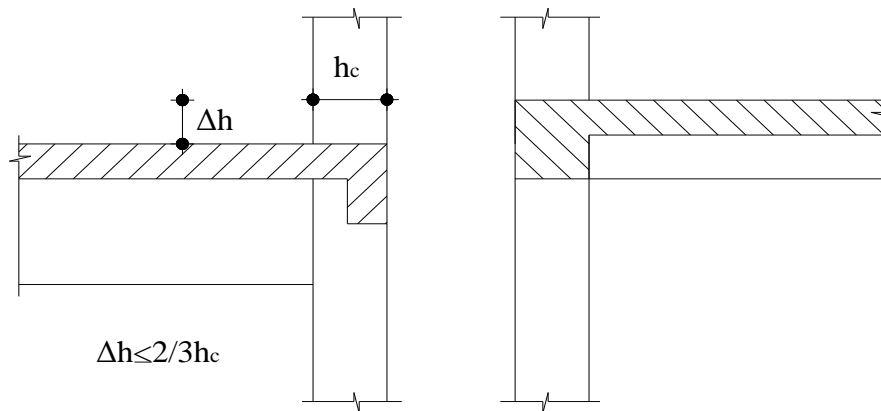

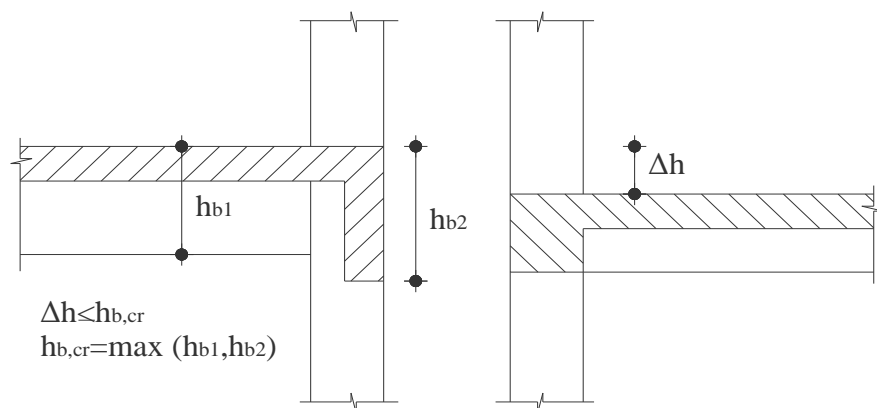

- b) When the above requirement is not met, it is recommended to infill with appropriate walls or wings behind the outer impacting columns, in the first bay in the direction of the potential impact.
- c) Alternatively, it is possible to strengthen these outer columns along their entire height until the foundation, thus increasing the seismic redesign loads of these columns by 100% (as calculated without taking into account the possibility of pounding).

To this end, for the strengthening of any of these two buildings, it is permitted to take into account this possibility by increasing the total redesign seismic load of the building by 50% (as calculated without taking into account the possibility of pounding).

4.8.2 In particular, for adjacent buildings with a number of storeys differing by 2 or more or a total height difference equal to or greater than 50%, is recommended to take into account the possibility of in- or out- of phase seismic pounding, in the best

possible way (however practically feasible).

- 4.8.3 In no case liability for potential damage of an adjacent building may be imposed because of the fact that a neighboring building has been strengthened against earthquake, see also § 1.3.3.

APPENDIX 4.1

BASIC DATA FOR MATERIAL RESISTANCES

1) Values of material properties and individual safety factors

The values of material properties (that determine any type of resistances) are defined in the attached Table 4.1, as well as the corresponding partial safety factors γ'_m based on the provisions of §§ 4.4.3 and 4.5.3.

This Table applies to concrete and reinforcing steel, as well as "unconventional" new added materials, regardless of whether they are covered by Standards or not.

For infill walls, existing or added, see 4.5.3.1.d §, § 4.5.3.2.c, § 4.5.3.3, § 7.4 and Chapter 8.

TABLE II 4.1: VALUES OF MATERIAL PROPERTIES (which determine the resistances) AND CORRESPONDING PARTIAL SAFETY FACTORS γ'_m

	VERIFICATION METHOD ¹					
	IN TERMS OF FORCES ²			IN TERMS OF DEFORMATIONS ³		
	EXISTING MATERIALS ⁶	ADDED MATERIALS COVERED BY STANDARDS		EXISTING MATERIALS	ADDED MATERIALS COVERED BY STANDARDS	
		Yes	No		Yes	No
Representative Values ⁵	— $\bar{X} - s$	X_k	X_k	— \bar{X}	X	X
Individual Safety Factors γ'_m ⁴	<i>Depending on the DRL</i>	Depending on cross section and / or accessibility		<i>Depending on the DRL</i>	Depending on cross section and / or accessibility	

¹) In general the Table is valid for both linear and non-linear analysis methods.

²) Verifications in terms of (internal) forces are made mainly in case of linear analysis methods, but also in case of non-linear ones for elements with quasi-brittle behaviour (μ_θ or $\mu_d < 2.0$ or $\mu_{1/r} < 3.0$) or for potential brittle failure modes (i.e. due to shear) or for basement or foundation elements etc.

³) Verifications in terms of deformations are made mainly in case of non-linear analysis methods for elements with quasi-ductile behaviour or for ductile failure modes.

⁴) γ'_m factors for existing materials are determined according to the data reliability level, while for added materials according to the cross section and the accessibility of the location of the intervention.

⁵) \bar{X} = mean value, X_k = characteristic value, s = standard deviation (see also Chapter 3).

⁶) In certain cases, verifications in terms of forces are made using mean values, as in the case of verifications in terms of deformation, see Chapter 9.

	$\gamma'_c = 1,50 \pm 0,15$ $\gamma'_s = 1,15 \pm 0,10$	$\gamma_m \cdot (1,05 \text{ or } 1,20)$	Increased	$\gamma'_m = 1,10 \pm 0,10$	$\gamma'_m = 1,15 \text{ or } 1,25$	$\gamma'_m = 1,15 \text{ or } 1,25$
--	--	--	-----------	-----------------------------	-------------------------------------	-------------------------------------

- Existing infill walls: $\gamma_m = 2.00 \pm 0.50$.
For existing infill walls low (“tolerable”) DRL is not permitted (see § 3.7.3). So, for intermediate or high DRL $\gamma_m = 2.00$ or 1.50 , respectively.
- Added infill walls: $\gamma_m = 1.70 \div 3.00$, see EC6

Mean values of materials’ strength (and standard deviations)

a) Existing materials

The representative value is equal to the mean value for verifications in terms of deformations (or, for certain verifications in terms of forces, see Chapter 9), or the mean minus one standard deviation (or, simply, the mean value) for verifications in terms of forces.

The mean value for a particular member (or group of similar members), is the established “nominal” (measured) value, as specified in the relevant Chapter 3, while the nominal standard deviation depends mainly on the type of material, as well as the quality and the time of construction.

In the absence of more precise data, and regardless of the data reliability level (DRL), the standard deviations of material strengths (normalized to average values) may be estimated as follows:

- Infill walls $s/f_m = 0.20 \div 0.40$
- Concrete $s/f_m = 0.10 \div 0.20$
- S 220 steel $s/f_m = 0.10$
- Old ribbed steel $s/f_m = 0.08$
- New ribbed steel $s/f_m = 0.06$

For materials with increased deviation of strengths (infill walls and concrete), the value of the standard deviation of the strength to be introduced in the calculations will depend on the overall quality of the project construction, uniformity, etc., according to the findings and conclusions of Chapter 3, at the discretion of the Engineer.

b) Added materials

The representative value is equal to the mean value for verifications in terms of deformations, or to the characteristic value (as foreseen by the relevant Standards) for verifications in terms of forces.

The average strength for modern, ordinary and “conventional” materials can be estimated as follows, based on the characteristic value:

- Infill walls $f_m = \min (1.5 f_k, f_k + 0.05 \text{ ή } 0.50 \text{ MPa, for shear or inclined compression respectively})$
- Concrete $f_m = \min (1.2 f_k, f_k + 5.0 \text{ MPa})$
- Steel B500(C ή A) $f_m = (1.10 \text{ or } 1.05) f_k, \text{ for } \Phi \leq 16 \text{ or } \geq 18 \text{ mm, respectively.}$

APPENDIX 4.2

THE INDIVIDUAL FACTORS WHICH DETERMINE THE UNIFORM q FACTOR

The uniform (global) behavior factor q of a structure is derived by multiplying the overstrength factor q_u by ductility factor q_π (see also EC8), i.e.:

$$q = q_u \cdot q_\pi$$

It is reminded that the q values for a structure, which include the favourable effect of hysteretic damping, may be different for the different principle directions of the structure, depending on the structural system and eigen period of vibration, but the class (and the classification in terms of) ductility is the same regardless of direction (in which the frames and/or shear walls of the structure are arranged).

- (a) The overstrength factor (q_u), expressed in terms of forces, is equal to the ratio of seismic force (base shear) V_u which corresponds to generalised yielding of several structural components (initiation of soft story mechanism, with risk of global instability) to strength V_1 corresponding to yielding (generally in bending) of the first component (whichever, but mostly primary and mainly at the “critical” floor, see next § d).

This factor depends on the structural system and its in-plan regularity and indeterminacy, the possibility of stress redistribution and (generally) from the available resistance (strength) reserve of the building after the onset of the first plastic hinge until the creation of a (floor) mechanism.

In principal, for purposes of assessment and redesign – regarding the q_u factor – the rules and provisions of EC8 may be used (see §§ 3.2.2.5 and 5.2.2.2 on a_u/a_1 , as well as § 4.3.3.4.2.4).

For the purposes of this Standard, in the absence of more precise data, the following Table may be used, which has been prepared according to the values recommended by EC8 and the complementary notes that follow.

	Structural system	$q_v (= V_u/V_1)$ (1)	
1	Inverted pendulum or torsionally sensitive systems	1.00	
	Shear wall or frame systems	Regularity in plan (2)	
		Yes	No (3)
2	<u>Shear Wall Systems</u>		
2.1	Only 2 uncoupled shear walls per direction, independently of the number of storeys	1.00	1.00
2.2	More than 2 uncoupled shear walls per direction, independently of the number of storeys	1.10	1.05
2.3	Any coupled or dual systems (wall equivalent system, walls' resistance at base >50% of total)	1.20	1.10
3	<u>Frame Systems</u>		
3.1	$\eta = 1$ (η : number of storeys, above the basement – if present)	1.10	1.05
3.2	$\eta \geq 2$, one bay	1.20	1.10
3.3	$\eta \geq 2$, multi-bay or dual systems (frame equivalent system, frames' resistance at base >50% of total)	1.30	1.15

(1) In EC8, the value V_u/V_1 is presented as a_u/a_1 , i.e. as the quotient of the respective normalised accelerations.

(2) On in-plan regularity, see next § e

(3) As a simplification, the overstrength of irregular (in-plan) buildings with respect to that corresponding to regular ones is given in EC8 by:

$$(V_u/V_1)_{MH-K} = [1 + (V_u/V_1)_K] / 2.$$

However, the values of the Table apply for new buildings (designed and built with current Standards), assuming modern, hardened and ductile (and weldable without conditions) steel, generally B500C (or even S500s), with average values of $f_t/f_y \approx 1.10$ and $e_u \approx 10\%$.

For older buildings with older technology steel, an appropriate adjustment is generally needed.

If the absence of more precise data, multiplication factors λ may be applied to the values of the Table in case of older buildings, depending on the longitudinal steel reinforcement of the primary members (for earthquake), as follows:

- For older steel classes St.I or S200, with $f_t/f_y \approx 1,40$ and $\varepsilon_u \approx 10 \div 12\%$, $\lambda = 1.1$
- For older high strength steel, with $f_{yk} = 400$ or 500 MPa, inferior in terms of hardening ($f_t/f_y \leq 1.10$) and ductility ($\varepsilon_u \leq 5\%$), $\lambda = 0.9$, with $q_v \geq 1.0$.

For proven more “brittle” steels (e.g. cold worked), it is recommended to consider $q_u = 1$.

However, a final value of $1.0 \leq q_v \leq 1.5$ is recommended regardless of the structural system, steel quality, analysis method, etc.

- (b)** The ductility factor (q_π), which is expressed in terms of deformations (e.g. displacements), is equal to the ratio of the ultimate deformation (depending on performance level) to the deformation corresponding to generalized yielding or onset of (storey) mechanism, with displacements (lateral or horizontal) with reference to the top of the building (at height H , see § 5.7.3.2) or to the region of application of the total (horizontal) resultant of the seismic force (at height H_{eff} , see next § c).

This factor, i.e. in approximation the ductility factor in terms of displacements for the whole building, also depends on the structural system and its regularity in elevation (along its height, this time), and its deformation and energy dissipation ability through cyclic post-elastic behaviour of individual (primary) components even at the “critical” storey (see next § d).

- (c)** Through this “uncoupling” between q_u (total overstrength) and q_π (ductility in terms of displacements for the entire structure), it is possible to estimate (i) the required ductility in terms of displacements or chord rotations at floor level (e.g. “critical”), and through the latter, (ii) the required ductility (in terms of d or θ , or $1/r$) for individual (mainly primary) structural elements of the storey. In the absence of more precise and detailed data, the following reasoning and methodology can be adopted:

- (i) The value of q_π varies in proportion to the building eigen period or vibration. For very small T , i.e. for response (practically) in the range of equal accelerations, $q_\pi \approx 1$, while for larger T (after the peak, the maximum of the acceleration spectrum), i.e. for response in the range of (practically) equal displacements, $q_\pi \approx \mu_d = \mu_\theta$.

Thus, the (global) relationship between q_{π} and μ_d , depending on the eigen period of the building, can be expressed as follows (see also § 7.2.6):

- For $T \leq T_C$ with $\mu_d = 1 + T_C/T (q_{\pi} - 1)$, while
- For $T \geq T_C$ with $\mu_d = q_{\pi}$

where T_C is the value of the characteristic period at the end of the region of constant spectral acceleration and the start of the descending branch of the (elastic or design) acceleration spectrum (see EC8), and T is the fundamental uncoupled eigen period of the building at the considered main direction (x or y), i.e. T_x or T_y for $q_{\pi x}$ or $q_{\pi y}$, respectively.

(ii) The (global) value of μ_d can be “translated” into ductility demand of the “critical” storey, in terms of displacements or chord rotations, $\mu_{d,op} \approx \mu_{\theta,op}$.

- For buildings which are regular in elevation with a uniform distribution and dispersion of resistances but also of inelastic demands, as in case of buildings with efficient and adequate shear walls or capacity-designed frames (at joints) in order to ensure (with reliability) the creation of quasi-plastic hinges at the ends of beams (or even at a few column ends over the height), the “critical” storey is generally the ground storey and the following expressions may be applied:

$$\mu_{\theta,op} (= \mu_{d,op}) \approx \mu_d, \quad \mu_d = f(q_{\pi}), \text{ see. (i).}$$

- For buildings which are irregular in elevation, and for which there is a possibility of formation of a “soft storey” in one or more adjacent floors at a height h , the ductility demand of this “critical” floor is clearly greater than that for regular buildings, according to the above paragraphs. For irregularity which is not due to pilotis (see below), and depending on the height h where the “soft storey” is expected to occur, the following expressions can be applied:

$$\mu_{\theta,op} (= \mu_{d,op}) \approx \mu_d \cdot H/h \leq 1.5\mu_d, \quad \mu_d = f(q_{\pi}), \text{ see. (i) .}$$

- For pilotis-type buildings, with a “soft” (or “weak” or “open”) ground storey, the previous approach for buildings irregular in elevation can be used with appropriate modifications. Thus, the height of the application of the total (horizontal) resultant seismic

force is $H_{\text{eff}} \approx 0.50H$, unlike the height of application of the total force for regular buildings, $H_{\text{eff}} \approx 0.65$ ($\div 0.80 H$, where important influence of higher modes is taken into account for high-rise buildings), and the following expressions may be applied:

$$\mu_{\theta, \pi\lambda} (= \mu_{d, \pi\lambda}) \approx \mu_d \cdot H_{\text{eff}} / h_s \approx \mu_d \cdot (H/2 / H:n) \approx (n:2) \cdot \mu_d \geq 1.5 \mu_d, \quad \mu_d = f(q_\pi), \text{ see. (i),}$$

where n is the number of storeys, including the pilotis, and h_s is the height of the pilotis / ground floor ($\approx H/n$).

Note

According to EC8, for buildings irregular in elevation with irregularities other than pilotis, a simpler approach has been adopted, as follows:

$$\mu_{\theta, \text{op}} (= \mu_{d, \text{op}}) \approx \kappa \cdot \mu_d, \quad \mu_d = f(q_\pi), \text{ with}$$

$\kappa = 1.00$ for regular buildings, and

$\kappa = 1.25$ for irregular buildings (instead of $\kappa = H/h \leq 1.5$, see above).

- (iii) The value of $\mu_{\theta, \text{op}} (= \mu_{d, \text{op}})$ can be “translated” into the ductility demand (in terms of curvatures, $\mu_{1/r}$), of critical sections of primary elements of the storey, i.e. elements with greater involvement in the undertaking of seismic force, on the condition (of course) that their behaviour is ductile under M and N (and not brittle, under V), i.e. that they will develop quasi-plastic (and not fracture) joints at their ends with $V_{R, \text{red}} \geq 1.15 V_{MR} = 1.15 M_R/L_s$ (rather than $V_{R, \text{red}} \leq 0.85 V_{MR} = 0.85 M_R/L_s$, respectively), with $L_s (= \alpha_s \cdot h)$ the shear span (where α_s is the shear ratio), and $L_s \approx 0.5 \cdot L$ for linear elements or $L_s \approx 0.5 \cdot H'$ for shear walls), see also § 7.1.2.6. In this context, $\mu_{1/r}$ is defined as the ratio of curvature at 85% of M_u (after the peak) to yield curvature (M_y).

For the purposes of the present Standard, the correlation between $\mu_{1/r}$ and $\mu_{\theta, \text{op}} (= \mu_{d, \text{op}})$ is presented in §§ 7.2.6 and 8.2.3.

- (iv) Thus, through the desired or target uniform behaviour factor q ($= q_v \cdot q_\pi$), the required ductility demand ratios in terms of curvatures ($\mu_{1/r}$) may be estimated at critical sections of the main structural members of the building (at the “critical” storey), or vice versa (under certain conditions).

- (d) For the purposes of the present Standard, namely for the uncoupling and estimation of the partial factors that determine q , the most stressed storey is considered (and is) the “critical” one, especially with respect to its primary members.
In this context, the “critical storey” is the ground storey, especially if it is “bare” i.e. with few masonry infills or glazing etc. (pilotis type). However a higher storey of the building may be “critical”, e.g. in cases of strong interaction between adjacent buildings, with an insufficient (seismic) joint and danger of pounding, see § 4.8.
- (e) Regarding regularity issues and the particularities in cases of masonry-infilled structures (mainly frame rather than shear walls structural systems), the following apply according to EC8:
- The increased uncertainties associated with the resistances of the bays, the influence of openings, the wedging of infills to the frame, the possible “alterations” (or modifications, demolitions, etc.) during the long-term use of buildings, uneven damage due to earthquakes, etc. should be taken into account.
 - Appropriate construction measures should be taken in order to limit damage, especially in cases of large openings or slender bays (with h/t or $l/t > 15$), such as arrangements of connectors, meshes, side-to-side tie beams etc.
 - It is noted that, according to § 5.4.3.c it is prohibited, in general, to selectively take infill walls into account e.g. only in some floors and / or regions of the building
 - Their potential global and local effect should be taken into account, particularly if adverse
 - The potential influence of masonry infills on issues of irregularity in plan and in elevation should be taken into account.

Regarding the plan:

In some cases with asymmetrical layout, a parametric investigation of the influence of masonry infills should be made, taking into account some and not all panels and/or a significant increase of accidental eccentricity of the storey under earthquake.

Regarding the elevation:

In adverse cases of “bare” storeys or impairment of the walls, action effects should be increased by the magnification factor

$$n = 1 + \Delta V_{RW} / \Sigma V_{Sd} \leq q,$$

only if this factor has values greater than 1.1, where ΔV_{RW} is the possible reduction of the overall shear resistance of infills and ΣV_{Sd} is the total shear force acting on all primary vertical members of the storey.

APPENDIX 4.3**VALUES OF NORMALISED BASE SHEAR UNDER EARTHQUAKE**

The values of normalised base shear under earthquake are presented in the attached Table II 4.2, i.e. the values of the term $S_d(T) = a_g R/q^*$ (for $T_B \leq T \leq T_C$), without coefficients γ_I , η , S and 2.5 according to EC8.

The values of this term are derived based on the provisions of § 4.4.1.2 (on earthquake actions) and § 4.6 (on uniform behaviour factor q in cases of application of linear analysis) with a reference value that corresponds to performance level (B) ("Life Protection") and a 10% probability of exceedance during the conventional 50-year structural life cycle according to EC8.

TABLE II 4.2 : VALUES OF THE TERM $S_d(T) = a_g R/q^*$ FOR BASE SHEAR, WITH REFERENCE VALUE CORRESPONDING TO PERFORMANCE LEVEL (B) AND PROBABILITY OF EXCEEDANCE 10% DURING THE 50-YEAR LIFE CYCLE (SEE. EC8)

PROBABILITY OF EXCEEDANCE DURING THE 50 YEARS	PERFORMANCE LEVEL		
	Immediate occupancy (A)	Life protection (B)	Collapse prevention (C)
10 %	≈ 1.65	1.00	≈ 0.70
50 %	≈ 1.00	0.60	≈ 0.45

Note

The Table applies also for assessment and redesign, with appropriate reference values with regard to performance level and probability of exceedance. Depending on the behaviour of the structure, there may be variations for performance levels A and C, see comments in § 4.6.1. Probability of exceedance equal to 50% within the 50-years, where the seismic action is reduced by about 40%, is allowed only in special cases, in the discretion and under the approval of the Public Authority (see § 4.4.1.2).

APPENDIX 4.4

THE RATIONALE OF THE SAFETY VERIFICATIONS DEPENDING ON STRUCTURAL PERFORMANCE

Based on the provisions of Chapters 2, 4, 7 through 9, the verifications may be presented according to the attached skeleton behaviour diagram, depending on the performance level (A through C) and the verification in terms of forces (through q or m factors) or deformations (through design deformation, $d_d \approx \theta_d$).

For more detailed descriptions and provisions, see §§ 4.1.1 through 4.1.4, 4.6, 4.7, 5.1.3 and 7.1, as well as Chapter 9.

Regarding the behaviour characteristics of the descending phase of the resistance of elements, after quasi-failure (F_u and d_u), which is of interest only for analysis and verifications using non-linear (inelastic) methods, and, indeed, only for components with clear ductile behaviour, and only for performance level C, “Collapse Prevention”, the following apply (see §§ 5.7.3.1 and 7.1.2.5):

- The residual resistance F_{res} , which is very difficult to be estimated, may be taken equal to a percentage of the ultimate resistance of the element $F_u (=F_y)$, i.e. $F_{res} = \alpha \cdot F_y$, see diagram below. For reinforced concrete elements, the ratio α may be taken equal to 25%.
- The maximum deformation d_{max} , which occurs at the total loss of resistance of the element, even under gravity loads, can not be reliably estimated. However, it can be estimated at most equal to twice the deformation at failure. For reinforced concrete elements, and only for the purposes of approximation of the response of the entire building after successive quasi-collapse of its individual components (in particular secondary elements), the multiplier β can be taken equal to 1.5, see diagram below.
- For existing, ordinary unreinforced infill walls, with predominantly brittle behaviour, there is no descending branch after failure. These components are checked in terms of forces or deformations and only for performance levels A and B. For performance level C, “Collapse Prevention”, they are not included in the model (and certainly are not checked), see § 7.4. However, their potentially unfavourable global or local effect must always be checked, or measures should be taken to reduce it, see § 5.9.

Only reinforced infill walls, existing (after strengthening) or added, and under the conditions of Chapter 8, may be taken into account after failure according to the previous points, with $\alpha = 0.25$ and $\beta = 1.5$ (as for reinforced concrete members).

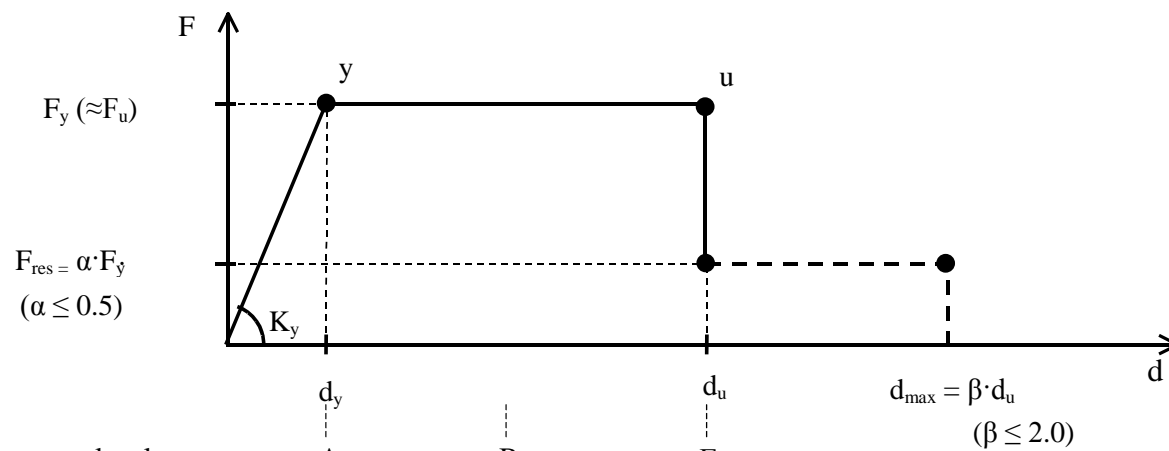

Performance level	A	B	Γ	
Uniform factor $q = q_u \cdot q_\pi$	$q_A \cong 0.6 \cdot q_B$ ($\cong 1.0 \div 1.5$)	q_B	$q_\Gamma \cong 1.4 \cdot q_B$	
Design deformation, d_d (or θ_d)	d_y	$\frac{1}{2} (d_y + d_u) / \gamma_{Rd}$	d_u / γ_{Rd}	for primary structural elements. (1)
	d_y	d_u / γ_{Rd}	d_u	for secondary structural elements (2)
	d_y	d_u / γ_{Rd}	d_u	for infill walls (3)

Skeleton Behaviour Diagram
(for individual structural elements, or for the structure as a whole)

Comments

- 1) For primary structural elements:
The ultimate design deformation (d_d), even for performance level C is less than that corresponding to quasi-failure (d_u), and with satisfactory reliability, expressed through γ_{Rd} (see Chapter 9).

- 2) For secondary structural elements:
For those elements, a greater degree of damage is acceptable (under earthquake) than for primary structural elements, depending on whether they are vertical or horizontal structural elements, for values of d_d defined also through γ_{Rd} (for performance level B but not C).
- In this context, secondary horizontal structural elements (and only them) may be excluded from the model and verifications for performance levels B and especially C, in cases of inelastic analysis. For performance level A, it is not permitted to distinguish structural elements into primary and secondary (see § 2.4.3.4).
- 3) For infill walls:
See previous reference inside this Appendix. Also see Chapters 5, 7 and 8.
- 4) For γ_{Rd} coefficients which determine the values of design deformations (d_d):
Their values are generally different, depending on performance level (B or C) and the type of member under verification. For performance level A, $\gamma_{Rd}=1$.
- 3) During simplified inelastic static analysis (see Chapter 5) where generally bilinear skeleton diagrams are used, it is allowed not to model the descending branch of the resistance.
- 4) For buildings for which the influence of higher modes is important (see § 5.7.2.b) the application of inelastic static analysis in combination with dynamic elastic analysis is recommended, so that all verifications are performed using both methods, while allowing a 25% increase of the values of factors q and m (see also § 9.3.1.b).

CHAPTER 5

ANALYSIS PRIOR AND AFTER THE INTERVENTION

5.1 General principles

It is not always feasible to ensure that the requirements and provisions of the Standards dealing with new structures meet the needs served by the Standards referring to existing ones. As a result, in terms of existing structures, it is

In order to determine the internal forces and deformations of the building it is required to analyze it numerically for the

BODY

legitimate (and sometimes expedient) to introduce additional concepts, requirements and provisions, always within the context of the same basic principles.

The elastic static analysis corresponds to the “lateral force method of analysis”, while the elastic dynamic analysis corresponds to the “modal response spectrum analysis” of EC 8 – 1 (§ 4.3.3). The terms used in this Standard were chosen to facilitate reference to the inelastic (non-linear in terms of material constitutive laws) methods. The selection criteria for the elastic analysis method based on the global behavior factor (q) or the local ductility factor (m) given in §5.5.5.

Such empirical method is for instance, the method using the building pre-earthquake assessment sheet (assessment of structural vulnerability) issued by the Hellenic Earthquake Planning and Protection Organization (EPPO)

It is recalled that this distinction is potential (i.e., left to the engineering judgment

combinations of actions defined in § 4.4.2.

Based on the resulting from an analysis internal forces and deformations using one of the recommended methods (§ 5.1.1), the respective verifications against the performance criteria set, are made as described in §§ 5.1.3 and 5.1.4, as well as in Chapter 9.

5.1.1 Methods of analysis

The methods that may be used for the analysis are:

- Elastic (equivalent) static analysis (see §5.5), with a global behavior factor (q) or a local ductility factor (m).
 - Elastic dynamic analysis (see §5.6), with a global behavior factor (q) or a local ductility factor (m).
 - Inelastic static analysis (see §5.7)
 - Inelastic dynamic analysis (response history analysis) (see §5.8).
- In special cases, e.g., when
- The assessment concerns a significant number of buildings, which it is aimed to determine whether there is, in principle, need for seismic strengthening (and with what priority), or
 - The building to be assessed is of low importance,

Then, in addition to purely analytical methods, the assessment may be done by empirical methods, subject to the conditions of § 2.1.4.1 b(iv).

5.1.2 Primary and secondary members

- a. The distinction of structural members into primary and secondary is made

of the Designer). The key difference between the two categories is related to what extent a member or sub-structure (e.g. frame, shear wall) is critical (and not just contributing) to the resistance against building collapse. Consequently, as secondary will be characterized those members which participate to system bearing vertical loads, but do not contribute significantly to the resistance against earthquake loading, or the degree of their contribution is rather unreliable, due to their low stiffness or strength or ductility (or due to the lack of construction control).

The (potential) distinction between primary and secondary structural members is made so as to offer the ability to differentiate the verifications (see also §5.1.3) for each category of members (the secondary may exhibit greater displacements and damage than the primary ones). Another reason is to avoid drawing the conclusion that a building is not sufficient because of the failure of some individual members which are not critical to its stability under seismic actions.

The distinction of the members into primary and secondary is particularly helpful (and expedient) in cases where:

- In a structure that is generally sufficient in principle (in terms of earthquake resistance), there are individual members that are practically impossible to meet the performance objectives set in this Standard; however, this weakness does not imply inevitable structural weakness (it is essentially a tolerance against an increased level of damage of particular members). In this category fall the shear wall coupling beams and, in general, the relatively short beams that frame to the walls (if not reinforced appropriately), beams indirectly supported on other beams, beams supporting columns in the upper storey etc. Such members can be characterized as secondary and the adequacy of the structure shall be verified without considering them (e.g. by assuming that they are “hinged” to the primary system).
- During the redesign of the building, new sub-structures are used (shear walls, trusses and more rarely, frames) which were designed to resist practically the sum of the seismic actions. In such a case, the existing (i.e., prior to intervention) structure can be classified as secondary.

according to § 2.4.3.4.

- b. The distinction between primary and secondary members does not concern the masonry infills (existing or added), which are taken into account as indicated in §§ 2.1.4.2 and 2.4.3.2.
- c. When secondary members and/or masonry infills are included in the numerical model as resisting horizontal forces, their verification should be made according to the prescriptions of Chapter 9.

5.1.3 Safety verifications

Thus, in the (rare) event that “Immediate Occupancy after the earthquake” is selected, it is expedient not to apply inelastic methods (which, in general, presuppose post-elastic response of the members).

The criteria for distinguishing the ductile and brittle behavior of a structural member are given in §§ 4.1.4 (iii) and 7.1.2.6.

e.g. the yield moment of a R/C beam.

- a. In the selection process of the analysis method, the performance level adopted according to § 2.2.2 shall be taken into consideration.
- b. Verification of the performance criteria (safety inequation) in terms of forces (internal forces) or deformations (deformation quantities) is made for each structural member as defined in Chapter 9, after it has been (potentially) classified as “primary” or “secondary” in accordance with §5.1.2.
- c. For the quasi-ductile failure modes (potential to develop post-elastic deformations without significant drop of strength), the verification is generally made in terms of deformations. For quasi-brittle failure modes (or in case of low shear ratio), the verification is generally made in terms of forces.
- d. Both the primary, and secondary members of the building shall be able to resist the forces and deformations that correspond to the verification of the inequation of safety (see Chapters 4 and 9).

5.1.4 Member resistance (for the purpose analysis)

- a. Where, for the purpose of an inelastic analysis method, the resistance of a structural member is calculated, the characteristic values of the material properties to be used shall correspond to the anticipated failure mode of the member.
- b. In case that the failure mode is ductile and the verification is made in terms of deformations, the mean values of the material properties shall be used as characteristic (§4.4.3).
- c. In case that the failure mode is brittle and the verification is made in terms of forces, the mean values of the material properties minus one standard deviation shall be used as characteristic (§4.4.3).
- d. The stress –strain relationships of the structural members are calculated in accordance to the general principles of §7.1 and the corresponding values for each member type as defined in §7.2 (for undamaged or new members), and §7.3 (for damaged ones).
- e. Respectively, the provisions of the relevant Chapter 8 generally apply for repaired and /or strengthened members of any type.

The main parameters to be considered in selecting accelerograms is the magnitude of the earthquake, the source-to-site distance, the soil conditions and the proximity of the recording station to the site of interest (geographical criterion). Scaling of the accelerograms to a common level of intensity is recommended to be made on the basis of spectral values, so that the characteristics of both the accelerogram and the structure are considered (in the elastic range). The spectral accelerations are functions of the fundamental period of the structure, hence, it is required to appropriately select the value or the period range for which the scaling factor will be derived. A commonly used parameter is the Housner spectral intensity, which refers to the area of the pseudo-velocity spectrum in the period range 0.1s to 2.5s. When the verification is made for a specific structure, it is expedient to reduce the period range for which the spectral acceleration is derived by assuming a relatively narrow bandwidth around the uncoupled fundamental period of the structure.

The purpose of this provision is to lead to a simplified and shorter evaluation process in those cases where there is a clear inadequacy (or, more rarely, a clear adequacy) of the assessed building.

The approximation generally involves the analysis of appropriate numerical models of individual parts (sub-structures) of the building. The selection of the appropriate approximate method depends on the type of the structural system under consideration. For frame or dual R/C structural systems, it is permitted to verify in an approximate manner the vertical members, by distributing the base shear (in each direction), proportionally to the moment of inertia of each member (or, proportionally to its cross-section area in the event that the work of the shear

5.2 Seismic actions for the purpose of analysis

- a. The seismic action for the assessment or redesign is selected as prescribed in Paragraphs §§ 4.4.1.2 through 4.4.1.4. For the analysis of the building, suitable pseudo-acceleration spectra or acceleration time histories are used for base excitation, the latter derived by deterministic or stochastic methods according to EC 8.
- b. In case that recorded accelerograms are used (§5.8.3.2), they must be scaled to the adopted intensity level of seismic action.

5.3 Approximate analysis

In some cases, i.e., when the following conditions simultaneously apply:

- a. The performance level adopted is the “Life Safety” or “Collapse Prevention” (see § 2.2.1), and
- b. There is no substantial damage or deterioration in the building,

Solely for the purpose of the assessment and in case that intervention (strengthening) is to follow, an approximate estimate of the demand on critical members of the structure can be made; without however, detailed numerical analysis of the entire building and provided that it has been confirmed by appropriate calibration that the

BODY

deformations is significant).

In case that the resulting shear in each member is very low (e.g. it does not exceed 35% of the value of $V_{Rd,c}$, as calculated according to EC2 for $\rho_f=0$), it can be assumed that the structure is adequate, whereas in case that it exceeds $V_{Rd,c}$ is inadequate. In (the most common) case where there is a clear inadequacy, verification may be restricted to the ground level.

The aforementioned condensed verification procedure can be followed for damaged buildings as well, in case that a full repair and restoration is to follow, according to Chapter 8.

This section refers to general analysis requirements that apply for all methods described in Paragraphs §§5.5 through 5.8. The general verifications are also described herein independently of the analysis method to be applied.

In general, the building shall be analyzed as a spatial finite element model, consisting of individual sub-structures and structural members. Alternatively, the use of a two-dimensional model is permitted, provided that the meets the following conditions:

- Rigid diaphragms exist (§5.4.6) and torsional effects do not exceed the limits prescribed in §5.4.2, or they are considered by the means described in §5.4.2, or
- Deformable diaphragms exist, as prescribed in § 5.4.6.

In case that two-dimensional finite element models are used, the three-dimensional character of the individual sub-structures and structural members shall be considered by an appropriate calculation of their stiffness and strength.

When the building includes setbacks, projections or discontinuities along the vertical structural system that resists horizontal forces, the finite element model shall take full account of the influence of these discontinuities on the diaphragm demand.

e.g. a beam-column joint

methods used lead to conservative and reliable results.

5.4 General modeling and verification requirements

5.4.1 Basic assumptions

- a. The building to be assessed or redesigned shall be numerically modeled according to EC 8. Modeling should take into account the actual supporting conditions to the ground (see also §3.5.4). In case of buildings with a basement surrounded by monolithic shear walls, the columns at the base of the ground floor can be assumed as fixed at their base. In all other cases, the potential assumption of complete fixity at the foundation level has to be adequately justified taking into account the issue of soil-structure-interaction.
- b. When non-linear analysis methods are used, connections that are weaker or

less ductile than the connecting members shall be included in the model.

5.4.2 Consideration of torsion

Based on both the characteristics of existing buildings (identified in the commentary of Paragraph §5.1) and also on the adoption of inelastic analysis methods by the present Standard, the effect of torsion-induced distress during the application of static methods can be considered, not according to EC8 but based on the following:

- The augmentative coefficient ‘ η ’ of the displacements in each floor shall be calculated as the ratio of the maximum displacement at any point of the diaphragm over the mean displacement ($\eta = \delta_{\max}/\delta_{\text{avg}}$).
- The increase of forces and displacement due accidental torsion shall be taken into account, unless (i) the corresponding torque is less than 25% of the existing (actual) torsion, or (ii) the augmentative coefficient of displacements ‘ η ’ due to the imposed seismic loads and the accidental eccentricity is less than 1.1 at each storey.
- When the *elastic* static method is used (§ 5.5), then forces and displacements due to accidental torsion shall be increased by the coefficient $(\eta/1.2)^2 \leq 3$, when the augmentative coefficient of displacements ‘ η ’ exceeds the value 1.2 in any storey.
- In case that the augmentative coefficient of displacements ‘ η ’ exceeds 1.5 in any storey, the use of two-dimensional finite element models is prohibited.

Other methods may also be used, provided that they are acceptable by the international literature. In any case, if the initial assessment without due consideration of accidental torsion indicates that the structure is inadequate, no further verification is required in this phase.

Both the *principle* (primary) and the secondary structural members are verified against the internal forces and deformations that result from the earthquake-induced seismic forces in combination with the respective vertical loads, as

- a. The influence of torsion around the vertical axis is not required to be taken into account for buildings with deformable diaphragms (§ 5.4.6).
- b. The increase (or decrease) of the internal forces and displacements shall be calculated in all other cases.
- c. The influence of torsion-induced distress shall be considered in the elastic analysis methods according to EC 8. When inelastic analysis methods are applied, the procedure should be adapted accordingly.
- d. When the inelastic static analysis method is used, and provided two-dimensional finite element models are used, the influence of torsion shall be calculated by multiplying the target displacement (δ_t) with the maximum value of ‘ η ’ as derived for any storey (from elastic analysis).

5.4.3 Finite element modeling of primary and secondary members

- a. In the models to be used for *elastic* analysis, the following are permitted:
 - In case that the assessment will lead to a decision for non-intervention, all structural members shall be taken into account,

prescribed in Chapter 9.

Verification of the 25% criterion may be practically made by two successive analyses of the structure; assuming a rigid and a hinged connection of the secondary elements to the remaining structural system, and subsequent verification of the criterion using the resulting storey displacements.

i.e., masonry infills, once included in the numerical model (according to § 2.1.4.2), they should be included in their entirety and not selectively at specific only storeys or building locations.

Existing and/or added

while

- In case that the assessment is to be followed by intervention (i.e., repair and especially, strengthening), it is permitted to take into account only the primary structural members (and, where appropriate, the masonry infills), provided that the secondary members fall into the categories prescribed in §5.1.2c and that the overall stiffness (against horizontal loads) of the secondary members does not exceed 25% of the stiffness of the primary ones. In all other cases, some secondary members will have to be classified as primary in order to reduce the stiffness of the secondary members below the above percentage of 25%.
- b. The finite element models to be used for *inelastic* analysis shall include both primary and secondary members. The reduction in stiffness and resistance of the primary and secondary members in the post-elastic range shall be explicitly modeled using appropriate constitutive laws (see also §7.1.2). In case of simplified inelastic static analysis (§5.7.3.1f) and under the conditions described in the previous paragraph, it is permitted to include only the primary members in the model, while the degradation phase of the member resistance shall be not be modeled.
- c. It is prohibited to selectively classify load-bearing structural members in the category of secondary, in a way that the structural system of the building is transformed from regular to irregular. The same applies for masonry infills, when included in the numerical model.

5.4.4 Assumptions regarding stiffness and resistance

- a. The stiffness and resistance of the members, prior and after any intervention, *with* or without damage, shall be calculated for each building type as prescribed in the relevant sections of the Standard, see Chapters 4, 7 and 8.
- b. The masonry infills of a building shall be included in the numerical model in accordance with §§ 2.1.4.2, 2.4.3.2 and 5.9. The corresponding shear and axial stiffness shall be taken in compliance to Chapters 7 and 8.

5.4.5 Morphology

The lack of regularity in a building (which also determines the range of validity of the simpler analysis methods, see also §§ 5.5.1, 5.6.1, 5.7.1), shall be verified according to its morphology in plan and along a vertical section (in elevation). See also relevant Appendix 4.2.

A building is classified as regular when it lacks one or more of the irregularities defined in §5.5.1.2, either by considering or not considering the secondary structural members or masonry infills.

5.4.6 Diaphragms

- a. The in-plane deformations of the diaphragm under the effect of the (distributed) seismic inertial actions and the reactions of the vertical members that are connected to the diaphragm must be taken into account in the calculation of the relationship coupling the displacements of the vertical members. To this end, it is permitted to classify the diaphragms into two categories: deformable and rigid.
- b. A diaphragm shall be classified as *deformable*, when the maximum in-plane horizontal deformation exceeds twice the average of the mean drift of the vertical members of the underlying storey. For diaphragms that are supported on basement shear walls, the drift of overlying storey shall be taken into consideration.
- c. A diaphragm shall be classified as *rigid*, when the maximum in-plane horizontal deformation along the diaphragm is lower than the half of the mean drift of the vertical members of the underlying storey.
- d. Diaphragms not belong to one of the above categories are classified as of *moderate deformability*, however, to simplify the analysis they can be classified to the most relevant category of the two (i.e., deformable - rigid).
- e. For the purpose of diaphragm classification, the interstorey drift and the deformations of the diaphragm may be calculated on the basis of the equivalent static loads of § 5.5.5.4. In the common case of reinforced concrete slab-beam systems, the corresponding diaphragm may be considered rigid, without detailed calculation, when its geometry and (in plane) strength are deemed

In case that no detailed assumptions are made, a reinforced concrete diaphragm can be considered as rigid if the following (simplifying) criteria are fulfilled:

- Existence of substantial perimeter beams, lack of abrupt changes in thickness and cross sections, or discontinuities in the arrangement of beams and/or

slabs,

- The system is not a solid slab without beams or indirect supports. This category does not include solid slabs without beams that have sufficient shear walls and trabecular slabs (of Sandwich type) again with sufficient shear walls.
- The elevations within the same storey are not intense (e.g., they are not higher than $h_b/2$, where h_b is the average height of the beams)
- The shape of the floor plan is compact (e.g. there is absence of large setbacks or projective sections, floor plans with elongated wings of Γ, T, Π shape etc.)
- There are no large gaps (openings) within the diaphragm, especially in vicinity of the shear walls (which are the predominantly primary load-bearing members).

The calculation of total inertial load of the diaphragm can be made on the basis of the procedure described in the commentary of §5.5.5.3.

In this peculiar case, the redistribution of demand among the vertical sub-systems is prohibited.

satisfactory.

- f. During the analytical verification (when this is required), the in-plane diaphragm deformation shall be calculated as:
 - i) Directly from the numerical model in which the diaphragm is considered, or
 - ii) By a separate numerical model which takes into account the combined action of the diaphragm inertial forces and the in-plane loads of the diaphragm that arise from discontinuities of the vertical system resisting seismic forces within the diaphragm plane.
- g. The numerical model of buildings having rigid diaphragms shall take into account the influence of torsion, as defined in §5.4.2. In buildings with deformable diaphragms, modeling of the diaphragm as an entity is made using in-plane finite elements whose stiffness is compatible with the mechanical properties of the materials composing the diaphragm.
- h. Alternatively, in buildings with deformable diaphragms at all storeys, each vertical sub-structure resisting seismic forces can be examined independently, taking into account the masses resulting from the respective areas of influence.

5.4.7 2nd order effects

The analysis of buildings will be made considering the static and dynamic 2nd order effects, as specified below.

5.4.7.1 *Static 2nd order effects*

- a. Static 2nd order effects shall be taken into consideration in both the elastic and inelastic analysis.
- b. In case of *elastic* analysis, when the resulting interstorey drift sensitivity coefficient θ (§4.4.2.2 of EC 8-1) is lower than 0.1, 2nd order effects can be ignored. When the index θ lies between 0.1 and 0.2, then the seismic forces and displacements at storey i shall be increased by a factor equal to $1/(1-\theta)$. When the index θ exceeds the value 0.2, then the building will be considered quasi-unstable, hence, its appropriate strengthening will be required in order to reduce its lateral displacements and the index θ results within the aforementioned limits.
- c. In case of *inelastic* analysis, static 2nd order effects shall be considered in the analysis incorporating in the numerical model the non-linear stress-strain relationship of all members bearing axial loads. The requirement of §b regarding the index θ *also* applies in this case.

5.4.7.2 *Dynamic 2nd order effects*

The dynamic 2nd order effects can be taken into account by an appropriate increase of the displacements that were derived by ignoring these effects.

This increase can be practically made, through the coefficient C3 of equation (S5.6), which is incorporated in the inelastic static method (§ 5.7).

e.g. by a percentage higher than 15%

5.4.8 Soil-Structure Interaction

- a. Soil-structure interaction (SSI) may be taken into consideration for those buildings where the increase of the fundamental period due to SSI leads to a subsequent increase of the spectral accelerations. For all other buildings, SSI effects can be ignored.
- b. SSI effects may be taken into account either by the procedure described

The effective fundamental period that corresponds to the first translational mode can be calculated by the relationship below:

$$\tilde{T} = T_0 \sqrt{\left[1 + \frac{k_o}{k_x} \left(1 + \frac{k_x h_{ef}^2}{k_\phi} \right) \right]}, \quad (\Sigma 5.1)$$

where T_0 is the fundamental period of the fixed-base structure, k_o is the corresponding stiffness, k_x and k_ϕ are the translational and rotational stiffness of the foundation (in the direction examined) and h_{ef} is the effective building height which can be taken as 2/3 of the actual height, with the exception of one storey buildings where it can be taken equal to the actual height. The foundation stiffness k_x and k_ϕ are calculated based on scholarly expressions from the literature.

The effective damping can be calculated as follows:

$$\tilde{\zeta} = \zeta_\theta + \frac{\zeta_0}{(\tilde{T}/T)^3}, \quad (\Sigma 5.2)$$

where ζ_0 is the damping ration of the fixed-base building (in general equal to 5%), and ζ_θ the damping ration of the foundation, as calculated based on scholarly expressions from the literature.

below (§5.4.8.1), or with any other scholarly and calibrated methodology that meets the requirements of §5.4.8.2.

- c. In cases where SSI effects do not have to be taken into account, it is permitted to ignore the influence of damping in the evaluation of the impact and the results of SSI.

5.4.8.1 Simplified procedure

- a. Use of the simplified procedure is permitted only in when the elastic static analysis is applied.
- b. The calculation of the influence of SSI, based on the simplified procedure, shall be made using the effective (equivalent) fundamental period and damping of the soil-foundation system.

- c. In case that the simplified procedure for the consideration of SSI effects is used, the reduction of seismic demand on the structural members shall not exceed 25% of the demand that results without considering SSI effects

5.4.8.2 Detailed modeling

- a. The detailed modeling procedure shall be used in combination with the elastic dynamic analysis method or with the inelastic analysis methods.
- b. The computation of the SSI effects on the basis of detailed modeling consists of the explicit numerical modeling of the stiffness and damping of the foundation members.
- c. In case that a more detailed approach is not followed, the equivalent damping ratio ζ of the superstructure-foundation system can be computed on the basis of the simplifying procedure of §5.4.8.1. The damping ratio of the foundation members shall not exceed the value that is adopted for the members of the elastic superstructure. In the framework of inelastic static analysis, the equivalent damping ratio of the superstructure-foundation system shall be used for the calculation of the spectral demands (i.e., target displacement).
- d. In case that the simplifying procedure for the calculation of the equivalent damping ratio is used, the reduction of seismic demand (compared to the ones resulting by ignoring SSI) shall not exceed 25%.

5.4.9 Spatial superposition of actions

In other words, what is applied is the 100% of a selected base shear in a given direction together with the 30% of the corresponding base shear in the other direction, until, the resulting displacement in the direction of the largest base shear reaches the corresponding target displacement (§ 5.7 .4.2). In buildings without significant asymmetry in plan (§5.5.1.g5) it is permitted for simplicity, to apply the loads in each direction separately, but after increasing the target displacement by 30%.

- a. The superposition and combination of seismic actions in space is performed in compliance to §§ 4.4.1.2. και 4.4.2.
- b. In the case that the inelastic *static* method is applied, the building shall be analyzed for loads in two directions, with a ratio of the corresponding base shear of 10:3 and (separately) of 3:10.
- c. In case that the inelastic *dynamic* analysis method is applied, the building shall be analyzed for simultaneous action of pairs of

accelerograms along the directions X and Y.

- d. The effect of *vertical* component shall be taken into consideration according to EC 8.

5.4.10 Combination of actions for assessment or redesign

The combinations of actions for assessment or redesigned are defined in §4.4.2.

5.4.11 Overturning verification

- a. The buildings shall be checked against overturning forces generated by seismic loads. The overturning verification shall be made at the base of the building, as prescribed in §5.4.11.1 in case of elastic methods and as prescribed §5.4.11.2 when inelastic methods are used.
- b. The influence of overturning forces at the foundation and on geotechnical structures shall be taken into account when assessing their strength and stiffness.

5.4.11.1 *Elastic methods*

When elastic methods are used, the resistance to overturning forces will result from the stabilizing action of the permanent loads. These loads can act either independently or in combination with other loads resulting from the connection of the structural members of the building (in general, the foundation) with other underlying entities (in general, the soil). The verification of the foundation members shall be made by taking into account the increased compressive loads that act at the vicinity of the edge point around which the structure tends to overturn.

5.4.11.2 *Inelastic methods*

In verifying a building against overturning around its base, by considering the entire structure, it is recommended to apply the method with the use of a global behavior factor (q), even if the members have been checked using local ductility factors (m).

In case that the overturning verification is not satisfied, a reliable connection/anchorage among the building members is required, above and below the level where the verification takes place. If this level is the base of the building, then a reliable connection must be ensured between the building and the soil, unless non-linear analysis methods are to be used for a rational assessment of the influence of uplift. The above connections must be able to resist the seismic action effects in combination with the vertical loads.

When inelastic methods are used, the effect of uplift in the side of the structure that is subjected to tension (due to the overturning moment), or the effect of rocking shall be modeled explicitly by introducing the corresponding non-linear degrees of freedom. The capacity of the members above and below the level of uplift or rocking, inclusive of those of the foundation, shall be verified by considering any possible redistribution of forces or deformations that is results from the aforementioned uplift or rocking.

5.5 Elastic static analysis

As regard to the performance level A, the elastic static analysis can be applied without the conditions set in § 5.5.2.

5.5.1 Definitions

5.5.1.1 Failure index of a structural member

The failure indices λ practically coincide with the ratios " ρ " of EC8-3 (§ 4.4.2), if $\rho_{\min} = 1$.

In the numerical model developed for the analysis, the secondary members shall be in general included, while for the masonry infills the provisions of §2.1.4.2 apply; however, without requiring calculation of the indices λ for the secondary members and the masonry infills themselves.

The ratios λ are calculated solely on the basis of bending resistance, firstly in order to reduce the relevant calculations and secondly because, even if when the elastic analysis method is selected (also taking into account the values of λ), the verifications against shear are made using a capacity approach (see Chapter 9), hence, the requirement for $\lambda < 1$ is checked for the shear that results from capacity design.

Apart from the fact that the ratios λ can be used for the definition of regularity, they provide an initial estimate of the building resistance to earthquake loading. For instance, if $\lambda > 4$ for a large number of members (over 1/3 of total), then the inadequacy of the building is pronounced and further assessment would be redundant.

In case of vertical members that are subjected to biaxial bending with axial force,

To determine the extent and distribution of inelastic demand in the primary structural members of the system resisting seismic actions, a preliminary elastic analysis of the building is required, so that the "failure indices" can be calculated for each member:

$$\lambda = S_E / R_m, \quad (5.1)$$

where S_E is the action effect (bending moment) due to the actions of the seismic combination (§4.4.2), where the seismic action is assumed without reduction (i.e., $q=1$), and R_m is the corresponding available resistance of the component, calculated on the basis of the mean values of the materials strength (see § 5.1.4).

The ratios λ shall be calculated for both assessment and redesign, for each primary structural member. The highest ratio λ of a single member in a given storey (i.e., the most highly distressed) shall be considered as the *critical ratio* λ for the entire storey.

the ratio λ (for bending and axial force) is easier to be calculated as the ratio of the required longitudinal reinforcement that results due to the bending moments (in both directions) and the axial forces corresponding to the action S_E of the seismic combination over the corresponding existing reinforcement. To determine the critical ratio for the entire storey it is not necessary to take account the beams with the exception of the beams of principal frames in pure frame systems.

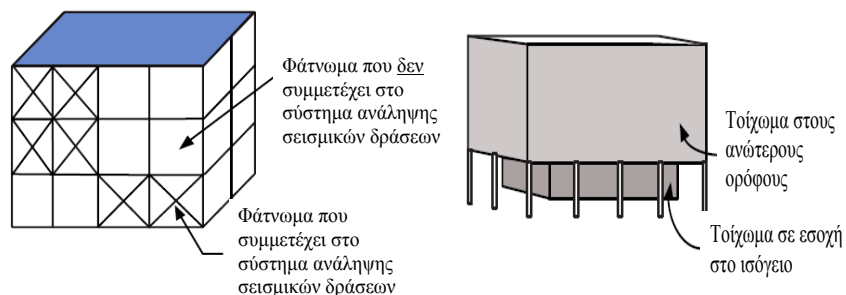

Figure 5.1 Examples of irregularity in elevation: interruption of the structure along its height (setback, left) out-of-plane projection (right)

A storey k for which $\bar{\lambda}_k > 1.5 \bar{\lambda}_{k-1}$ or $\bar{\lambda}_k > 1.5 \bar{\lambda}_{k+1}$ is called weak in bending and shear. It is not necessary to check this condition when $\bar{\lambda}_k \leq 1.0$.

5.5.1.2 Regularity

The range of applicability of each method referred in §5.1.1 depends on the morphological characteristics of the building, which affect its behavior under seismic actions. A building is considered as morphologically regular if it satisfies the conditions indicated in EC 8-1. Particularly for existing buildings, the following conditions may alternatively apply:

- a. No individual sub-structure resisting seismic actions is interrupted along the height neither it continues to a different bay.
- b. No individual sub-structure resisting seismic actions continues to a successive storey as an out-of-plane projection.
- c. The building does not include a storey for which the average rate of the failure index λ_k exceeds 150% of the average failure index of a nearby (underlying or overlying) storey, where:

$$\bar{\lambda}_k = \frac{\sum_1^n \lambda_i V_{Si}}{\sum_1^n V_{Si}}$$

(5.2)

As principal elements, the primary structural members are meant.

Such a storey is called *torsionally* sensitive.

In this relationship, λ_i is the failure index for the principal member i of the storey, V_{Si} is the corresponding effective shear (from an elastic analysis for $q=1$), and n is the number of the principal members belonging in storey “k”.

- d.** The building does not include a storey for which, for a given direction of seismic action, the ratio λ of a member located in one of its sides, over the corresponding ratio of another member located in any other side (of the same storey) exceeds 1.5. The rule applies to storeys where the overlying diaphragm is not deformable in-plane.

For elastic methods no conditions are set for their application as regard to the level of data reliability.

As a criterion for this condition, and provided that the diaphragm is not deformable, the rule can be used that the interstorey drift in each side of the building does not exceed 150% of the average drift.

As a criterion for this condition, the rule can be used that the average interstorey drift (with the exception of non-structural elements) does not

5.5.2 Conditions of application

The application of static elastic method is permitted under the conditions set in EC 8-3. Especially for the buildings of our country, the following apply:

- a.** The application of static elastic method is permitted (for performance levels B or C, see § 5.5) when the following conditions are satisfied:
- (i) For most principal members $\lambda \leq 2.5$ applies, or for one or more of these members $\lambda > 2.5$.
 - (ii) The fundamental period of the building T_0 is lower than $4 T_c$ or $2s$, (see EC8-1).
 - (iii) The ratio of the horizontal dimension in a given storey over the corresponding dimension in a successive storey does not exceed 1.5 (with the exception of the uppermost storey and non-structural elements)
 - (iv) The building does not present significantly asymmetric distribution of stiffness in plan, in any storey.

exceed 150% of the drift of the underlying or underlying storey.
This verification is not required in adequate, dual systems.

The main objective of this paragraph is twofold: (a) to prevent the disclosure of the method (which presents the apparent advantages of simplicity and general overview) due to the fact that the conditions of application of §5.5.2 are only rarely fulfilled simultaneously, particularly in case of older buildings, and (b) to facilitate the use of the same analysis method for both the assessment and redesign (where it is more likely that the conditions of application will be fulfilled).

The fundamental period is estimated on the basis of reliable expressions from the literature. For buildings in our country, the following empirical relationship can be used:

$$T_0 = C_t h_n^\beta, \quad (5.3)$$

where, $C_t = 0.052$ and $\beta=0.90$ for R/C buildings, while height h_n is denoted in m.

- (v) The building does not present asymmetric distribution of mass or stiffness.
- (vi) The building has a system for resisting seismic actions in two, approximately perpendicular with each other, directions.
- b.** Independently of the applicability of conditions i, iii, iv and v of the preceding paragraph, provided that no substantial damage exists and for assessment purposes (only), the application of the static elastic method is permitted. In this case, the epistemic (modeling) safety factors γ_{sd} prescribed in § 4.5.1 shall be increased by 0.15.

5.5.3 Background of the method

- a.** The numerical modeling of the buildings shall be made with the assumption of “elastic” stiffness and viscous damping, which correspond to the first yield of the members (see Chapters 4, 7 and 8). The analysis for equivalent static loads (§ 5.5.5) shall be made for calculating both forces *and* deformations.
- b.** Based on the analysis results, the corresponding verification of the performance criteria shall be made (see Chapret 9).

5.5.4 Determination of the fundamental period

- a.** The fundamental period is estimated through modal analysis using an appropriate numerical model of the building.
- b.** Alternatively, it is permitted to use the Rayleigh-Ritz method or any other reliable empirical expression.

5.5.5 Determination of internal forces and deformations

The total horizontal (pseudo-static) load shall be calculated on the basis of §5.5.5.1 ή 5.5.5.2 and shall be distributed along the height according to the provisions of EC 8.

5.5.5.1 Determination of the equivalent static loads in the framework of the global behavior factor method

When the analysis is made using the global behavior factor (q) method, which is estimated on the basis of §4.6, the total horizontal load (i.e., base shear) on a building along a given direction shall be calculated according to EC 8 and those specifically mentioned in this Standard.

5.5.5.2 Determination of the equivalent static loads in the framework of the local ductility factor method

The method based on the global behavior factor (q) generally leads to results similar or more conservative than those derived with the use of the local ductility (m) methodology, hence it is generally recommended for structures that present a uniform distribution of the plastic deformation demand (e.g. in the case of buildings with weak first storey). For structures where a less uniform distribution of the plastic deformation demand is anticipated (and provided that the other conditions of the elastic static analysis are fulfilled) the local ductility (m) method is recommended.

The structural displacements are directly obtained by solving for the forces that result from the seismic action that in turn corresponds to the base shear of the relationship (5.6), while the forces are calculated by dividing the corresponding internal forces with the m -factors defined in Chapters 4, 7 and 8.

In special case, such as buildings with fundamental period $T_1 > T_C$ where T_C the corner period denoting the initiation of the descending branch of the EC 8

a. When the analysis is made using the local ductility factor method (m), see Chapters 4, 7 and 8, the base shear in each direction shall be calculated in such a way that the displacements can be calculated with adequate accuracy taking into consideration (i) the inelastic response of individual structural members and (ii) the influence of higher modes.

b. To implement the requirement of § a, when a more precise approach is not adopted, it is possible to use the following formula to calculate the base shear:

$$V = C_1 C_m \Phi_e W, \quad (5.3)$$

where:

C_1 : Coefficient that relates the expected maximum inelastic displacement with the displacements calculated by linear

spectrum, the value of C_1 can be used as per the prescriptions of § 5.7.4.2a.

Not analytical verification is required in case of reinforced concrete diaphragms for which the conditions given in the commentary of §5.4.6 (e) are fulfilled.

When the diaphragms are not modeled, then their inertial forces can be calculated by the equation:

$$F_{px} = \sum_{i=x}^n F_i \frac{m_x}{\sum_{i=x}^n m_i} \quad ,$$

(S5.4)

where F_{px} the total inertial force of the diaphragm within plane x and F_i , m_i , m_x are defined as in EC 8

In other words, what is verified is their strength and not their deformation capacity, also see §7.1.2.6.

elastic analysis; taken equal to 1 for simplification

C_m : Effective mass coefficient (to account for higher modes) that can be taken equal to 0.85

Φ_e : Spectral acceleration corresponding to the fundamental period T according to §5.5.4 and 5.4.8. In case that the predominant eigenperiods in each building direction deviate significantly, then, Φ_e is taken equal to the corresponding value in each eigenperiod.

W: The weight corresponding to the total vibrating mass of the structure.

5.5.5.3 Distribution of seismic loading

The distribution of seismic loading along the height shall be made according to EC 8.

5.5.5.4 Diaphragm forces

- a.** When analytical verification is made, the diaphragms shall be checked either on the basis the internal forces resulting from the numerical model wherein the diaphragms are considered, or, through a separate numerical model under the combined action of the inertial forces and the forces resulting due to setbacks or stiffness discontinuities of the vertical members above and below the diaphragm. The forces due to stiffness discontinuities of the vertical members shall be taken equal to those resulting from eq. (5.6) without any reduction (unless a more accurate analysis or the assumption of capacity design is made). These forces shall be directly added to the inertial diaphragm forces.

The seismic load of each deformable diaphragm shall be distributed along the diaphragm proportionally to the deformed shape of the diaphragm.

- b.** In diaphragms subjected to forces due to stiffness discontinuities of the vertical members, the verification shall be made in terms of forces.

5.6 Elastic dynamic analysis

The application of elastic dynamic analysis method is permitted under the conditions set in EC8-3. Especially for the buildings of our country, the following requirements (§ 5.6.1.) alternatively apply. These conditions are not compulsory for performance level A.

5.6.1 Conditions of application

- a.** The field of application of the elastic dynamic analysis is defined by the condition that $\lambda \leq 2,5$ is valid for all principal members.
- b.** Independently of the applicability of the conditions of the previous paragraph, and provided that no substantial damage exists, the application of the elastic dynamic method is permitted, (solely) for the objectives of the assessment. In this case, the epistemic (modeling) safety factors γ_{sa} prescribed in §4.5.1 are increased by 0.15.

5.6.2 Background of the method

In the numerical model of the buildings, the values of linear elastic stiffness and viscous damping shall correspond to the response of their structural members close to yield.

5.6.3 Numerical modeling and analysis

5.6.3.1 General

The seismic action for dynamic analysis shall be defined according to §5.2.

For elastic methods no conditions of application are imposed as regard to the reliability level of the data.

With respect to the reasons that this possibility is given, see the commentary of §5.5.2β.

Along these lines, the yielding force of the members shall be estimated on the basis of mean material strength values, see Chapter 4, 7 and 8.

When elastic dynamic analysis is used, either the EC8 spectrum or acceleration time histories compatible to the above spectrum (in accordance to the provisions

of EC 8) shall be applied as seismic action.

5.6.3.2 Response spectrum method

- a.** The dynamic analysis for the determination of the maximum spectral quantities shall be based on the response spectrum method, using a sufficient number of modes, according to the provisions of EC8.
- b.** The maxima of the internal forces, displacements, storey forces, storey shears and base shears for each mode of vibration shall be combined according to the relevant provisions of EC8.
- c.** The spatial superposition of the above quantities shall be made based on the provisions of EC8.

5.6.3.3 Response history method

- a.** The response history analysis shall be performed using either recorded or artificial accelerograms for base excitation.
- b.** The damping matrix shall describe the damping characteristics of the structure close to member yield.
- c.** If at least three accelerograms are used, then the validation shall be made for the *maximum* value of each response quantity resulting from the response history analysis (and their respective simultaneously acting effective quantities, when necessary). If seven or more accelerograms (or pairs of accelerograms for analysis in 3D space) are used, then the verification can be made with the *average* response quantities.
- d.** The spatial superposition of seismic actions shall be made in accordance to §5.4.9. Alternatively, it is permitted to analyze the numerical model in space for simultaneous action of pairs of horizontal components (accelerograms), each one acting along a principal axis of the building.

e.g. maximum bending moments, or shear forces and the corresponding axial loads

5.6.4 Determination of internal forces and deformations

5.6.4.1 Modification of the demand

Along these lines, displacements and deformations shall be multiplied by the coefficient C_1 of §5.7.4.2. The local indices m given in Chapters 4, 7 and 8 take into account the corresponding effect in the internal forces.

In other words, the diaphragm forces shall correspond to $q = 1$. In case that local ductility factors are used (m), then there is no need to multiply the diaphragm forces by the coefficient C_1 of § 5.7.4.2.

- a. When the analysis is made with the use of the global behavior factor method (q), the deformations are calculated either by response spectrum analysis (§5.6.3.2) or by response history analysis (§5.6.3.3). In the latter case, deformations shall be multiplied by the behavior factor (q) in order to take into consideration the influence of the inelastic response of individual structural members.
- b. When the analysis is made with the use of the local ductility factors (m) all action effects (internal forces and deformations) that are derived by analysis, either by response spectrum analysis (§5.6.3.2) or by response history analysis (§5.6.3.3) shall be appropriately increased to take into account the influence of the inelastic response of individual structural members (§5.7.4.2).
- c. In all cases, action effects (internal forces and deformations) shall be increased to account for the effect of torsion according to §5.4.2.

5.6.4.2 Diaphragms

The diaphragms will be verified for the combined action of forces resulting from the dynamic analysis, as well as of those developed due to stiffness discontinuities in vertical members above and below the diaphragm. The forces arising from the dynamic analysis may not be taken less than 85% of those arising under the provisions of the EC 8. The forces developed due to stiffness discontinuities in vertical members shall be taken equal to the elastic forces without reduction, unless a more precise analysis justifies the use of reduced values.

5.7 Inelastic static analysis

5.7.1 Background of the method

5.7.1.1 Scope of the analysis

The method is sometimes referred to as the force control method. Apart from the values of inelastic deformations, this method also provides the internal forces developed in those members that have entered the post-elastic range of response. These values are generally more reliable than those calculated using elastic methods (and potential capacity design verifications).

Also see §7.1

In practice, it is sufficient to draw the pushover (capacity) curve up to a point that corresponds to displacement which is larger (say, by 50%) than the target displacement (see also § 5.7.3.1).

As regard to the development of the capacity curve, see §5.7.3.4.

e.g. a response history analysis of an appropriate numerical model for a series of seismic excitations. This assumption is valid under the condition that the dynamic response of the building is dominated by the first mode of vibration.

The main objective of inelastic static analysis is to estimate the amplitude of the inelastic deformations that develop in the structural members when the building is subjected to the level of seismic action for which the assessment or redesign is made. For predominantly ductile members, their strains are directly compared with the respective design values given in Chapter 9.

5.7.1.2 Fundamental assumptions of the method

- a.** In the framework of inelastic static analysis, the numerical model of the building shall explicitly take into account the non-linear characteristics of the stress-strain relationship of the structural members.
- b.** This numerical model shall be subjected to horizontal loads that are distributed proportionally to the inertial seismic forces and are monotonically increased until one of the structural members is not able to bear its own vertical load. This analysis leads to the *capacity (pushover) curve* of the building, which is in general plotted in terms of base shear versus displacement of a characteristic point of the building (control point), typically located on its roof (also see §§5.7.3.2, 5.7.4.2). This capacity curve is the key for all the required verifications of the performance criteria.
- c.** Once the seismic action is defined (for the assessment or redesign), the verification of the performance criteria is made on the basis of the displacement of the control point that corresponds to this seismic action. What is checked is that, for this target displacement, the resulting strain (rotation at yield and plastic rotation) of the ductile members does not imply a degree of damage higher than the damage that is tolerable for the target performance level of the building (see Chapters 4 and 9).
- d.** In the absence of a more precise calculation, the displacement of the control point (*target displacement* δ_t) which results from the seismic action (either for the assessment or redesign) can be estimated by the displacement response spectrum that

corresponds to a ductility compatible to the building displacement.

- e. For the determination of the target displacement, it is permitted to use acceptable simplifying methods as described in the following paragraphs.

5.7.2 Conditions of application

All methods of analysis are practically equally sensitive to the variation of the basic data (it is recalled herein that the parameters of resistance also affect the elastic analysis according to the present Standard, since the stiffness of the members depend on their yield moment). The same, in principle, also applies to the subsequent safety verifications (Chapter 9). It is recommended however, when inelastic static method is applied, to ensure a minimum “satisfactory” DRL given the widespread among the engineers perception that a high quality numerical analysis has to be based on equally reliable data.

In order to verify this assumption, an initial elastic dynamic analysis is required by taking into account those number of eigenmodes that activate at least 90% of the total mass. Next, a second elastic dynamic analysis shall be performed solely based on the predominant eigenmode in each direction. The effect of higher modes may be deemed significant when each storey shear resulting from the initial analysis exceeds 130% of the corresponding one resulting from the second analysis.

For the above dynamic analyses, the elastic spectrum of EC 8 ($q=1$) is used according to Chapter 4.

That is, when the global behavior factor method (q) is used, then it can be increased by 25% (in relation to the values specified in § 4.6), whereas, when the local ductility factor (m) is adopted, the increase of 25% refers to the values defined in Chapters 4 and 9.

The inelastic static method is recommended when at least a “satisfactory” data reliability level (DRL) is ensured.

- a. The inelastic static method is applied in buildings wherein the effect of higher modes is not significant.
- b. When the effect of higher modes is significant, the inelastic static analysis can be applied, provided that it shall be applied in combination with a complementary elastic dynamic analysis (according to §5.6, independently of other conditions of application of the elastic dynamic analysis). In this case, all the verifications prescribed of both methods have to be conducted. Moreover, an increase of 25% is permitted in the values of those parameters that are involved in the verification criteria of both methods.

5.7.3 Modeling and analysis

5.7.3.1 General

The reason is twofold: (a) to ensure that the bilinear curve to be used for the verification will be representative of the available building capacity and (b) to ensure that the analysis will converge at the level of the displacement set for verification. As a minimum, the curve shall be plotted up to 150% of the target displacement (§ 5.7.4.2), provided that no premature failure of the structure has taken place (when member failure is modeled).

It is however recommended to plot a “complete” capacity curve, that is, up to a displacement that corresponds to a substantial drop of strength of the structure (see Figure 5.2). Apart from the maximum building capacity, this curve additionally provides an estimate of the available displacement ductility (μ_{δ}), independently of the value that will be eventually adopted for the relevant verification (i.e., for the validation of factors q and m according to §4.6).

For the shell elements or the equivalent diagonal link of the shear panel that are used for the numerical modeling of

- a. The capacity curve, that is, the relationship between the base shear and the horizontal displacement of the control point (§5.7.3.2) shall be developed for control point displacements ranging from zero to the displacement for which the verification is to be made.
- b. The vertical loads of the structural members shall be included in the numerical model, in order to be combined with the horizontal loads in accordance to the seismic combination of actions prescribed in EC 8. The horizontal loads shall be generally applied in two opposite directions (i.e., one “positive” and one “negative”) and the verification shall be made for the most critical action effects that will result for each member.
- c. The numerical model shall adopt the appropriate level of refinement in order to take into account the stress-strain relationship at every location of potential inelastic behavior.
- d. The numerical model shall include in general, both the primary and secondary structural members, as well as the infill panels, according to §§5.4.3 and 5.4.4.
- e. The stress-strain relationship of each member shall be modeled through complete monotonic loading curves up to failure, which shall include degradation of strength of the ductile member and

masonry infills, an appropriate approximation (typically tri-linear) of the envelope of the τ - γ (or N - ε for the case of diagonal links) is utilized. The branch of the residual strength shall be terminated at a point compatible with the in-plane or out-of-plane failure of the masonry infills, solely for reinforced masonry walls (see Chapter 8).

A similar simplification can be applied for unreinforced masonry infills as well.

As prescribed in EC 8-1, the following distributions may be applied:

- a "Uniform" distribution, based on lateral loads proportional to the mass of each storey independently of its level (uniform acceleration response)
- a "Modal" distribution, proportional to lateral loads that are compatible with the distribution of horizontal forces in the direction examined, as resulting from elastic analysis.

its residual capacity, according to §7.1.

- f. Alternatively, it is permitted to use a simplified version of inelastic static analysis, by only modeling the primary members of the building that resist seismic forces, under the conditions of § 5.4.3. The stress-strain relationship of each such member shall be bilinear, without explicit modeling of strength degradation of the member.
- g. In the simplified inelastic static analysis, the load-bearing structural members that do not fulfill the verifications of Chapter 9 shall be considered as secondary and shall be removed from the numerical modeling of the building.

5.7.3.2 Determination of the control point

The control point of the target displacement shall be taken in general at the center of mass of the building top. For buildings with attics or small bungalows, the control point shall be taken at the roof of the underlying storey. Moving of the control point shall be justified by analysis under lateral static loads.

5.7.3.3 Distribution of lateral loads in elevation

The lateral static load shall be applied at the level of each diaphragm (storey slab), according to the distribution of inertial seismic loads. For all the analyses, the application of at least two different lateral load profiles is required, in order to take into account (to the greatest possible extent) the alteration of the force distribution due to both the post-elastic behavior at specific locations of the structure

It is recommended that the idealized capacity curve (force-displacement relationship) is bilinear (see also §7.1), with a slope of the first branch equal to K_e and slope of the second branch equal αK_e . The two lines that compose the bilinear curve can be defined graphically, on the criterion of approximately equal areas of the sections defined above and below the intersection of the actual and the idealized curves (Figure 5.2).

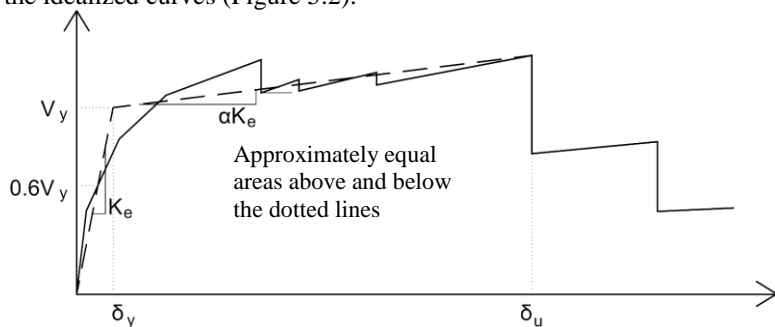

Figure 5.2 Idealization of a (indicative) capacity curve with a bilinear curve

The equivalent lateral stiffness K_e is determined as the secant stiffness that corresponds to a force equal to the 60% of the yielding force V_y , the latter defined by the intersection of the lines above.

The normalized inclination (α) of the second branch is determined by a straight line passing through the point of the (actual) non-linear capacity curve that corresponds to the ultimate displacement (δ_u), beyond which a significant drop of the strength of the structure is observed (Figure 5.2).

In any case, the derived value of α must be positive (or zero), but not larger than 0.10 (in order to be compatible with the other assumptions made by the method for estimating the target displacement δ_t , such as the coefficient C_1 , see § 5.5 .5.2 b and § 5.7.4.2).

The recommended fraction of the resistance reduction is 15%, provided that no primary vertical member has reached failure at this level (in such a case, the bilinearization of the curve shall be made for the displacement that corresponds to this failure).

and the influence of higher modes.

5.7.3.4 Idealized force-displacement curve

The non-linear force-displacement relationship that relates the base shear with the displacement of the control point (§ 5.7.3.1a) shall be replaced by an idealized curve for the determination of the equivalent lateral stiffness K_e and the corresponding yield strength V_y of the building.

As a simplification, and provided that the estimation of the available ductility of the building is not required, the slope K_e can be taken equal to the secant stiffness at a strength level equal to 60% of maximum resistance (V_{max}), whereas the yield force V_y , used for the calculation of the coefficient R in equation (5.7) can be taken equal to 80% of V_{max} .

The value T_e of the equivalent fundamental period is derived by the following expression:

$$T_e = T \sqrt{\frac{K_0}{K_e}},$$

(5.5)

where T is the elastic fundamental period in the direction under examination, that is derived on the basis of an elastic dynamic analysis, K_0 is the corresponding elastic lateral stiffness, while the equivalent lateral stiffness K_e is determined according to §5.7.3.4.

5.7.3.5 *Determination of the fundamental period*

The equivalent fundamental period in the direction examined shall be estimated based on the idealized capacity curve of §5.7.3.4.

5.7.3.6 *Finite element analysis*

- a. For two-dimensional analysis, two (possibly) different numerical models shall be used, that should be representative of the structural system of the building along two perpendicular axes. In case that these lines do not exist, the analysis shall be performed in three-dimensional space, using a numerical model that is representative of the entire structural system of the building.
- b. The influence of torsion is taken into account in accordance with §5.4.2.
- γ. The spatial superposition of seismic actions shall be made in accordance with §5.4.9.

5.7.4 Determination of internal forces and deformations

5.7.4.1 *General*

See, for instance, the methodology adopted in Annex B of the EC 8 (EN1998-1, 2004), which is slightly more complex than that of §5.7.4.2.

- α.** For buildings with rigid diaphragms at each storey level, the target displacement δ_t can be calculated in accordance with §5.7.4.2, or another acceptable methodology that takes into account the inelastic behavior of the building.
- β.** For buildings with deformable diaphragms at each storey, the in-plane deformability of the diaphragm shall be automatically considered in the numerical model. The target displacement shall be calculated as in buildings with rigid diaphragms, but shall be increased according to the ratio of the maximum displacement of the roof (at any point), to the displacement of the center of mass of the roof. These two displacements shall be calculated from response spectrum (elastic) analysis of a spatial numerical model of the building.
Alternatively, in buildings with deformable diaphragms at each storey, the target displacement can be calculated separately for each sub-structure resisting seismic actions. The target displacement for each individual sub-structure shall be calculated as in buildings with rigid diaphragms, after appropriate determination of the masses corresponding to each sub-structure.

As a simplification, these masses may be determined based on the respective areas of influence.

- γ.** The internal forces and deformations which are derived from the analysis at the time that the displacement of the control point is equal to δ_t , shall be verified in accordance with the criteria of Chapter 9.

5.7.4.2 Target displacement

If a more accurate method is not used, the target displacement δ_t can be calculated using the following equation (5.8) and be corrected (where

- a.** The target displacement δ_t (§ 5.7.1.2) shall be calculated taking into account all the relevant factors affecting the displacement of

necessary) according to §5.7.4.1 as follows:

$$\delta_t = C_0 C_1 C_2 C_3 (T_e^2 / 4\pi^2) S_{e(T)} \quad (5.6)$$

where $S_{e(T)}$ is the elastic spectral pseudo-acceleration (derived from the EC8 spectrum) corresponding to the equivalent fundamental period of the structure T_e (the latter calculated using the point of contraflexure in the force-displacement diagram of the system, as defined in § 5.7.3.4) and C_0 , C_1 , C_2 and C_3 being correcting factors that are defined as follows:

C_0 : Coefficient that relates the spectral displacement of the equivalent elastic system of stiffness K_e ($S_d = [T_e^2 / 4\pi^2] \cdot \Phi_e$), with the actual displacement δ_t of the top of the structure, which is assumed to be responding as an elasto-plastic system (§ 5.7.3.4). The values of this coefficient can be taken equal to 1.0, 1.2, 1.3, 1.4, 1.5, for a number of storeys equal to 1, 2, 3, 5, and ≥ 10 , respectively.

The ratio $C_1 = \delta_{inel} / \delta_{el}$ of the maximum inelastic displacement of a building to the corresponding elastic displacement may be obtained from the following relationships:

$$C_1 = 1.0 \quad \text{for } T \geq T_c \quad , \text{ and}$$

$$C_1 = [1.0 + (R-1)T_c / T] / R \quad \text{for } T < T_c \quad ,$$

where T_c is the corner period initiating the descending branch of the response spectrum (see EC 8) and $R = V_{el} / V_y$ the ratio of the elastic demand over the yield strength of the structure. This ratio can be estimated from the relationship:

$$R = \frac{\Phi_e / g}{V_y / W} \cdot C_m \quad ,$$

(Σ5.7)

where the yield strength V_y is calculated by appropriate bilinearization of the force (base shear) – (top) displacement relationship of the building, as defined in § 5.7.3.4. For simplicity, (and conservatively), the ratio V_y / W in equation (5.7) can be taken equal to 0.15 for buildings with a dual structural system, and 0.10 for buildings with a pure frame system.

C_2 : Coefficient that takes into account the influence of the shape of the hysteresis loop on the maximum displacement. Its values may be obtained from Table S5.1.

Table 5.1: Values of coefficient C_2

a building that responds inelastically. It is permitted to consider the displacement of an elastic single degree of freedom system with a fundamental period equal to the fundamental period of the building (§ 5.7.3.5) that is subjected to the seismic actions for which the verification is made. An appropriate correction is needed in order to derive the corresponding displacement of the building assumed to be responding as an elastic-perfectly plastic system. To this end, the following have to be taken into consideration, even in an approximate manner,:

- The difference between elastic and inelastic displacements
- The difference between the displacement of the aforementioned SDOF system and that of the “control point” of the building
- The difference between the displacement of a elasto-plastic SDOF system and that of a corresponding system with degrading stiffness during cyclic loading
- The impact of second order effects on the displacements.

Performance level	T = 0.1s		T ≥ T _c	
	type 1 system	type 2 system	type 1 system	type 2 system
Immediate Occupancy	1.0	1.0	1.0	1.0
Life Safety	1.3	1.0	1.1	1.0
Collapse Prevention	1.5	1.0	1.2	1.0

As systems of Type 1 are denoted those low ductility structures (e.g. buildings constructed prior to 1985 or buildings whose capacity curve is characterized by an available displacement ductility which is lower than 2), that are expected to have inferior hysteretic behavior than structures with high ductility (i.e., Type 2 systems, e.g. buildings constructed after 1985, or buildings whose capacity curve is characterized by an available displacement ductility which is higher than 2). Given the fact that the influence of hysteretic behavior is greater for higher levels of post-elastic structural response, the values of the coefficient C_2 are conditioned to the performance level.

C_3 : Coefficient that takes into account the increase of displacements due to second order (P-Δ) effects. It can be taken equal to $1+5(\theta-0.1)/T$, where θ is the interstorey drift sensitivity coefficient (see EC 8-1). In the common case (for R/C and masonry buildings) where $\theta < 0.1$, the coefficient is taken equal to $C_3=1.0$.

See § 5.4.6e for cases where the analytical verification can be omitted.

b. The target displacement shall be increased appropriately to take account torsion effects, as defined in § 5.4.2.

5.7.4.3 Diaphragms

The diaphragms shall be verified against the combined action of the horizontal loads developed due to stiffness discontinuities in the vertical members above and below the diaphragm, and the inertial forces of the diaphragm, which are calculated either from equation (5.6) or according to §5.6.4.2.

5.8 Inelastic dynamic analysis

5.8.1 Conditions of application

When the inelastic dynamic analysis method is used, it is recommended to ensure a “satisfactory” DRL (see related comments in §5.7.2). The Public Authority decides as regard to the means for certifying the qualifications of the Civil Engineer, as well as for any additional verifications required for the application of this method.

The condition for applying the method is the adequate experience and expertise of the Civil Engineer.

5.8.2 Background of the method

- a. The numerical model shall explicitly account for the non-linear characteristics of the stress-strain relationship of all the structural members of the building, and shall be subjected at its base to seismic action in the form of acceleration time histories, in accordance with § 5.2, in order to calculate both internal forces and displacements.
- b. The internal forces and displacements that are calculated by this analysis method shall be directly verified using the corresponding design values, see Chapter 9.

5.8.3 Numerical modeling and analysis

5.8.3.1 *General*

In general, it is expedient to verify the results of the inelastic dynamic analysis against the results of an inelastic static analysis using the same numerical model and an identical level of seismic action.

The modeling-related requirements specified in §5.7.3 for inelastic static analysis are also applicable for the inelastic dynamic analysis, with the exception of the provisions dealing with the control point and the target displacement.

5.8.3.2 *Seismic action*

See relevant provisions of EC 8.

During inelastic dynamic analysis, seismic action shall be input in the form of acceleration time histories at the base of the structure, using either recorded or synthetic accelerograms.

5.8.3.3 *Response history analysis method*

- a. During inelastic dynamic analysis, the response history shall be derived for horizontal base excitations, input according to §5.8.3.2.
- b. The spatial superposition of seismic actions shall be performed according to §5.4.9.

5.8.4 Determination of the internal forces and deformations

- a. The internal forces and displacements shall be computed according to §5.6.3.4. Torsional effects shall be accounted for as defined in §5.4.2.
- b. The diaphragms shall be verified for the combined action of the forces that result from the dynamic analysis, which in turn include the forces develop due to stiffness discontinuities in the vertical members above and below the diaphragm.

5.9 Masonry infills

Also see §5.4.3.γ and § 5.4.4.β

5.9.1 Exempt from the obligation of consideration

It is mandatory to consider masonry infills as part of the system resisting seismic forces, when this assumption has a detrimental effect on the structure, either at a global or a local level (see § 2.1.4.2 and 5.9.2).

Buildings can be excluded from this obligation provided that at least one of the following conditions applies:

They have been designed and constructed according to the provisions of the Hellenic Seismic Code (EAK 2000) and the Hellenic Code for Reinforced Concrete (ΕΚΟΣ 2000) or newer codes.

The additional lateral stiffness due to masonry infills does not exceed $\frac{1}{4}$ of the total lateral stiffness of the structure.

In this case, it has to be verified that even an unintentional arrangement of the masonry infills, would not cause detrimental response, regardless of whether significant damage is observed or not.

The numerical modeling of a masonry infill can be performed either through a shear panel or (for simplification) by an equivalent diagonal compression link element. The equivalence of the axial stiffness ($E A_p$) of the diagonal with the shear stiffness ($G A_\phi$) of the panel is based on the relationship (see also § 7.4):

$$EA_p = \frac{GA_\phi}{\cos^2 a \sin a},$$

where “ α ” is the angle of the equivalent diagonal (identical for the two diagonals of each panel). In the elastic analysis of three-dimensional numerical models, and when equivalent diagonal elements are used, it is permitted to be considered the latter in a cross-tie arrangement. In this case, when one diagonal is in tension, the other is in compression and hence, there is no need for successive iterations in each analysis in order to retain only those members that remain under compression). On the contrary, each diagonal is given half of aforementioned axial stiffness-driven ($EA_p/2$).

This numerical modeling approach is the only feasible in case of elastic dynamic (modal) analysis. In case of inelastic analysis and provided that the appropriate software is available, a pair of cross-diagonals can be used with an axial stiffness of EA_p each and a uniaxial constitutive law (i.e., compression-only).

In case that the masonry infills have openings, the respective constitutive relationships are appropriately modified in order to simulate the generally adverse effect of these openings (see § 7.4).

5.9.2 Criteria for detrimental effect

The masonry infills, are considered as not having an adverse effect on the structure when they do not increase the seismic shear of at least one primary vertical member or the seismic displacement of a storey by more than 15% at any level of the building.

During this verification, the elastic static analysis of §5.5 is unconditionally applied for the calculation of seismic shears in the primary vertical members.

For the numerical modeling of masonry infills, and towards the above verification, simplifications are permitted as described in Chapters 7 and 8.

CHAPTER 6

BASIC BEHAVIOUR MODELS

6.1. Load transfer mechanism models

In the case of interventions in reinforced concrete structures, the design of interfaces is a necessary part of the study. Related calculations are used:

- (a) To evaluate the bearing capacity of the cracked sections that have been developed due to damage in structural members (according to Chapter 7 and 8 of this Standard) and
- (b) For the design of interfaces between existing and added materials, according to Chapter 8 of this Standard.

Note that this Chapter is expected to be revised more frequently, as research on load transfer issues is ongoing and therefore, the relevant knowledge shall not be considered as fully established.

The compressive deformations in both the old and the new concrete are higher along the interface of the two materials. This leads to a locally reduced modulus of elasticity as well as to increased average deformations, especially in case of high stresses (i.e., close to the compressive strength). However, in most cases, this phenomenon can be neglected.

This phenomenon is attributed to:

- a) The unavoidable presence of simultaneous shear deformations along the interface, which bring the rough edges of the crack into touch before the elimination of its nominal opening, and

This chapter contains information regarding the behavior of the interface between materials, as well as guidelines for the design methods of these interfaces.

As the design of interfaces depends on the characteristics of the connected and the connecting materials and given the variety of materials available in the market, it is the principles of design that are given in this Chapter, whereas for further information, the designer shall refer to Chapter 8, to other normative documents and to Certificates and Specifications of specific materials or material groups.

6.1.1 Concrete-to-concrete load transfer

6.1.1.1. *Compression along the interface between the old and the new concrete*

The compressive strength perpendicular to the interface between an old and a new concrete with compressive strength $f_{c,old}$ and $f_{c,new}$ respectively, may be taken equal to the compressive strength of the weaker of the two concrete parts.

6.1.1.2. *Compression of pre-cracked concrete*

The application of compression perpendicular to a pre-cracked surface leads to the development of compressive stresses even before the crack is fully closed.

b) The presence of material trapped within the interface (trimmings, dust).

In any case, cyclic loading (consecutive openings and closings of the crack) result to the gradual reduction of the compressive stress that can be transferred by quasi-“open” cracks.

The maximum value of bond is activated for very small values of relative slip along the interface (ranging from 0,01 mm to 0,02 mm).

Typically, the weakest is the old (existing) concrete. The average value of f_{ct} that has been determined on the basis of the investigation tasks prescribed in Chapter 3 of this Standard is taken as the f_{ct} of the existing concrete.

The loss of chemical bond between the two concrete parts during the imposition of large displacements as well as the smoothing of the interface during and because of the large amplitude cyclic displacements, may cause significant reduction of bond.

Conservatively, the compressive stresses that are activated prior to the complete crack closure may be neglected.

6.1.1.3 Bond between old and new concrete

Bond is the maximum shear stress (strength), which can be transferred along an interface, when the normal compressive stress on the interface is zero and when there is no well-anchored reinforcement on either side penetrating the interface. Bond is mainly due to the chemical bond between the new and the old concrete.

- b) Under controlled conditions of orderly and long-term maintenance after the casting of the new concrete, the value of the bond strength along the interface can be taken equal to:
- 0,25 f_{ct} , for smooth concrete surfaces, without any prior treatment (e.g. the surface resulting during the casting, after smoothing with a trowel)
 - 0,75 f_{ct} , for interfaces that have been artificially roughened, before the casting of the new concrete (by sandblasting, water jet, etc.)
 - 1,00 f_{ct} , when the new concrete is applied over the old one by shotcreting or is set under pressure or when the new concrete is casted after the implementation of a strong binder (e.g., an epoxy resin) on the interface.

In the above relationships, f_{ct} is the tensile strength of the weaker of the two concrete parts.

- c) In general, bond is not accounted for when the verifications are carried out at the ultimate limit state.

However, in cases where the increased strength of the members (that results from the bond) is unfavorable, the bond

In these cases, the shear resistance is activated for relatively large values of relative slip; hence, the elimination of bond is more likely.

Such discontinuity may be the interface between old and new concrete, or the interface along an existing closed crack.

The friction coefficient decreases with increasing normal compressive stress on the interface. This decrease is especially pronounced in the case of small values of σ_0 (see Figure C6.1).

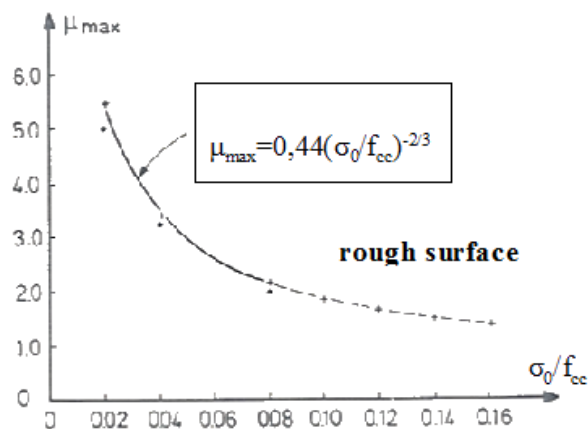

Fig. C6.1: Variation of friction coefficient (along a rough interface or crack) versus compressive stress on the interface.

In general, σ_0 includes (a) the normal compressive stress due to external loading for each combination of actions under consideration and (b) the corresponding

should be taken into account.

- d) In the case of interfaces that are subjected to vertical compressive stress (either due to external loading or due to the action of the clamp of the penetrating reinforcement), bond shall not be added to the friction activated during slip.

6.1.1.4 Friction between old and new concrete

- a) The shear stress that is transferred through friction along a concrete discontinuity is a function of the relative slip, s , of the two surfaces, the normal compressive stress, σ_0 , at the interface as well as the roughness. The shear strength, τ_u , can be practically calculated by the formula:

$$\tau_{fu} = \mu \sigma_0 \quad (6.1)$$

where: μ is the friction coefficient, characteristic of the interface roughness and a function of normal stress σ_0 .

In case that the interface is expected to undergo cyclic displacements, an appropriate reduction of the frictional shear resistance shall be taken into account.

BODY

compressive stress due to clamp action of the reinforcement which may penetrate the interface (see § 6.1.1.5). In the case of smooth interfaces, the contribution of the clamp mechanism is small and can be neglected.

A linear variation of the frictional shear stress with the relative slip shall be taken into consideration for values of s_f ranging from 0 to s_{fu} (Fig. C6.2). For higher values of slip and for a wide range of s_f values, it can be considered that the shear resistance is retained constant and equal to its maximum value (equation (6.2)).

The design value of the frictional shear strength of an interface, τ_{fud} , can be calculated through the relationships referred to in the following paragraphs:

- b) Smooth interface
In case of a smooth interface (as defined in § 6.1.1.3), the friction coefficient is taken constant and equal to 0.4. Thus, the maximum frictional resistance (for large values of tolerable slip) is calculated as follows:

$$\tau_{fud} = 0,4\sigma_{cd} \quad (6.2)$$

where: σ_{cd} is the design value of the minimum total normal compressive stress on the interface.

In case that the unfavorable influence of friction is taken into account, then a coefficient equal to 0.6 shall be used instead of 0.4.

The maximum shear resistance according to the relationship (6.2) is mobilized for relative slip on the interface approximately equal to:

$$s_{fu} = 0,15\sqrt{\sigma_{cd}} \quad [\text{mm, MPa}]$$

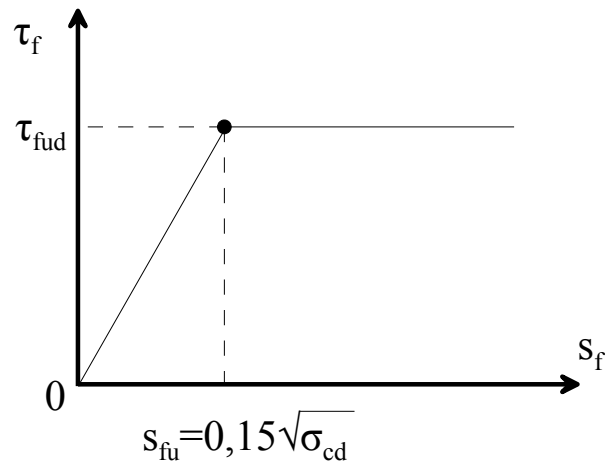

Figure C6.2: Diagram of the shear stress with the relative slip along a smooth concrete interface [MPa, mm]

Under the conventional assumption of seismic design with three complete cycles, i.e., for $n = 3$, the residual frictional resistance results equal to $0,3\sigma_{cd}$ or $0,45\sigma_{cd}$ for favorable and unfavorable effect of friction, respectively.

The reduced, due to large cyclic slip, maximum frictional resistance can be calculated by the following formula:

$$\tau_{fud,n} = \tau_{fud} (1 - \delta \sqrt{n-1}) \quad (6.4)$$

where: $\tau_{fud,n}$ is the shear resistance after “n” cycles
 τ_{fud} is the shear resistance during the first cycle (as derived by equation (6.2))
 $\delta = 0,15$ (constant).

c) Rough interface

In case of a rough interface, the maximum shear stress that is transferred through friction may be calculated as follows:

$$\tau_{fud} = 0,4 (f_{cd}^2 \sigma_{cd})^{1/3} \text{ [MPa]} \quad (6.5)$$

where: f_{cd} is the design value of the compressive strength of the weaker of the two concrete parts of the interface.

The value $s_{fu}=2,0$ mm applies in case that the interfacial resistance is due to friction only. In the usual case in which the resistance is attributed to simultaneous friction and dowel action, the maximum resistance of the interface is activated for slip values that do not exceed 1,0 mm.

When large relating slip along an interface is not expected (or permitted, see § 8.1.2.3a), the activated shear resistance (that is lower than the maximum) can be calculated as follows:

$$(a) \text{ For } \frac{s_f}{s_{fu}} \leq 0,5 \rightarrow \left(\frac{\tau}{\tau_{fud}} \right) = 1,14 \sqrt[3]{\left(\frac{s_f}{s_{fu}} \right)} \text{ [mm, MPa]} \quad (C6.1)$$

$$(b) \text{ For } \frac{s_f}{s_{fu}} > 0,5 \rightarrow \left(\frac{\tau}{\tau_{fud}} \right) = 0,81 + 0,19 \frac{s_f}{s_{fu}} \text{ [mm, MPa]} \quad (C6.2)$$

where $s_{fu}=2,0$ mm.

The reduced shear resistance after n cycles can be calculated using the following formula:

$$\frac{\Delta\tau_n}{\tau_1} = 0,05 \left(\frac{f_c}{\sigma_0} \right)^{1/2} (n-1)^{1/2} \left(\frac{s_f}{s_{fu}} \right)^{1/3} \quad (C6.3)$$

where

s_f : is the maximum imposed cyclic slip ($< s_{fu}$)

$\tau_1(s)$: is the maximum shear resistance during the first cycle for an imposed slip equal to s_f

σ_0 is the compressive stress perpendicular to the interface, which results as the sum of the externally imposed compression and the compressive stress that is due to clamp action of the reinforcement that intersects the interface.

$s_{fu}=2,0$ mm or 1,00 mm, as previously.

Besides, during the sign alteration of the relative slip, the maximum frictional resistance is reduced by 25% compared to the initial one.

$$(\tau_1^- = 0,75\tau_1^+).$$

In case that the unfavorable influence of friction is taken into account, the coefficient 0.4 shall be replaced by a factor of 0.6.

The maximum shear resistance in equation (6.5) is activated for relative slip along the interface, s_{fu} , that is approximately equal to 2mm.

When the relative slip “s” is less than “ s_{fu} ”, the activated reduced frictional resistance shall be calculated by appropriate methods.

The imposed cyclic slip along the interface causes a significant reduction in frictional resistance due to smoothing of the interface. This reduction shall be appropriately taken into account in design.

Moreover, the reduction of frictional resistance immediately shall be taken into account, right after the first change of sign of the slip.

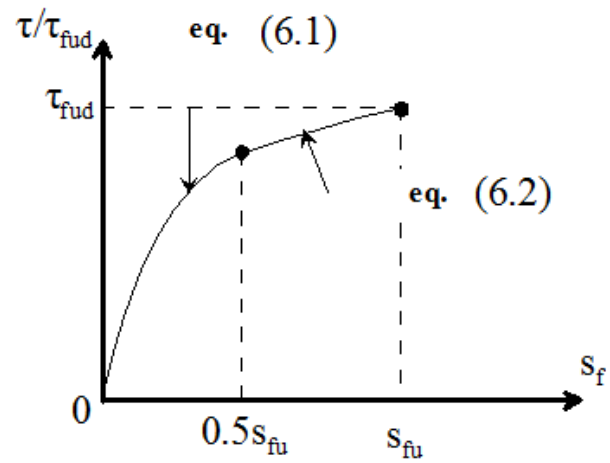

Figure C6.3: Shear stress-relative slip diagram along a rough concrete interface (schematic).

6.1.1.5 Friction due to reinforcement clamp action

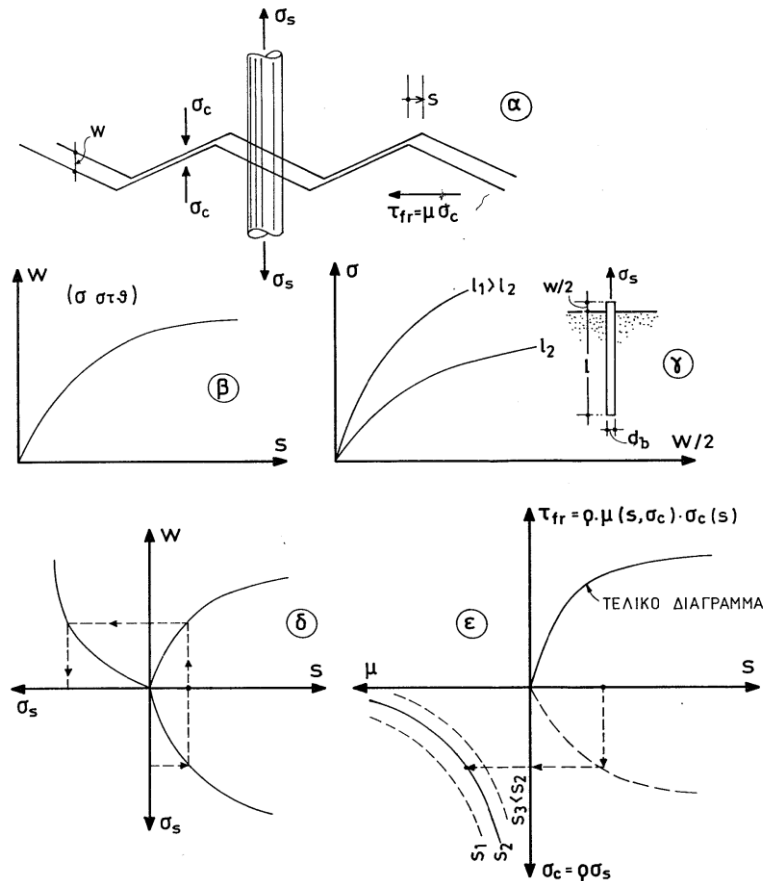

Figure C6.4: The clamp action: (a) schematic illustration of a rough crack, (b) variation of the crack width as a function of the relative slip, (c) tensile stress in the reinforcing rebar versus crack width and anchorage length, (d) calculation of the reinforcement stress as a function of the imposed slip, (e) calculation of the shear stress due to clamp action as a

- a) In case of rough interfaces, the slip imposed leads to an increase of the crack width, which in turn mobilizes the tensile resistance of any well-anchored reinforcement that may intersect the interface. These internal stresses are balanced by additional compressive stresses that develop in the concrete, which (along with the compression stresses that are due to the external loads) contribute to the frictional shear resistance of the interface. This mechanism is called clamp action of the reinforcement.
- b) Provided that (i) the interface undergoes sufficiently large slip and (ii) the reinforcement is adequately anchored to either side of the interface (i.e., with an anchorage length on either side of the interface, larger than ℓ_b), so that it can develop its yield strength f_{yd} , the maximum shear resistance at the interface is calculated using the following general formula:

$$\tau_{fRd} = \mu(\rho f_{yd} + \sigma_{cd}) \leq 0,3f_{cd} \quad (6.6)$$

where: μ : friction coefficient that corresponds to the normal stress $\sigma_{ol} = \rho f_{yd} + \sigma_{cd}$
 ρ : ratio of reinforcement perpendicular to the interface
 σ_{cd} : external compressive stress on the interface.
 f_{cd} : design value of the concrete compressive strength.

function of the imposed slip.

As shown in Figure C6.1, the coefficient of friction that depends on the compressive stress, which is exerted on the interface as a percentage of the compressive concrete strength, varies from 5 to less than 1. Therefore, it is generally not possible to be considered as a constant value.

However, for values of relative slip that are greater than 2,0 mm, the frictional resistance starts dropping. Usually, such large values of relative slip are not tolerable for any of the performance levels that are specified in this Standard.

Equation (6.7) results from eqs. (6.5) and (6.6) and is valid provided that slip along the interface is feasible, so that the maximum resistance is mobilized.

For larger resin thicknesses (indicatively, for thicknesses greater than 1,0 mm), the influence of the resin thickness in the strength and deformation of the interface shall be taken into consideration. The conditions for preparing the concrete surface are described in the "Recommended Technical Specifications for Retrofitting" (PETEP, Technical Chamber of Greece, 2008).

In the case of a rough interface and under the condition of large tolerable relative slip of approximately $s \sim 2\text{mm}$, the well-anchored reinforcement that perpendicularly intersects the interface is deemed to develop stress equal to its yield strength. Then, the total shear resistance of the interface under monotonic loading is calculated using the following formula:

$$\tau_{\text{fud}} = 0,4 \left(f_{\text{cd}}^2 [\sigma_{\text{cd}} + \rho f_{\text{yd}}] \right)^{1/3} \leq 0,3 f_{\text{cd}} \quad (6.7)$$

- c) In the case of tolerable relative slip that is lower than s_{fu} ($\sim 2,0$ mm), the mobilized shear resistance shall be calculated on the basis of the analytical models of § 6.1.1.4 and 6.1.2.1.

6.1.1.6. Force transfer through an epoxy resin layer

a) Compression

The compressive strength perpendicular to a concrete interface which is filled with very thin resin, can be taken equal to the compressive strength of the weaker concrete.

b) Tension

When a concrete interface, which is filled with very thin resin, is subjected to tension, its strength will be taken equal to the tensile strength of the weaker concrete, provided that

Unlike what happens in the case of concrete-to-concrete contact, bond in the concrete-resin-concrete interface continues to develop even for large values of slip along the interface. Nevertheless, due to incomplete data in calculating the shear resistance of the interface, bond is also neglected in this case.

For the design of various types of industrial anchors, see fib "Design of fastenings in concrete, Design Guide-Parts 1 to 6", 2009 (draft).

These anchors or dowels are at some extent of their length "a-posteriori" embedded into the old concrete (with which they are connected with the use of an appropriate resin), while the rest of their length is "a-priori" installed into the new concrete at the stage of concreting. Systematic compaction and maintenance of concrete is deemed a prerequisite at these areas.

the application specifications of the material used are followed.

c) Shear

When concrete connection using resin has been performed in compliance to the relevant rules (according to Chapter 8) and appropriate preparation of the interface has been made, the interface bond can be deemed equal to the tensile strength of concrete.

The shear resistance at the interface results as the sum of the friction that is due to external loads (§ 6.1.1.4) and the friction that is due to clamp action § 6.1.1.5).

Given the sensitivity of resin bond to moisture and temperature, as well as to the conditions of preparation and application, it is recommended to generally neglect the contribution of bond to the shear strength of the interface.

6.1.2. Force transfer between steel and concrete through anchors and dowels

Steel components are installed at interfaces (usually vertically), in order to transfer tensile and/or shear forces between the old concrete and the new concrete or the additional steel component.

For this purpose, industrial anchors are used or alternatively, bolts of different types or cuts of (ribbed) reinforcing bars that are anchored to the concrete through resin.

When cuts of reinforcing bars are used to connect the old with the new concrete, the behavior of anchors or dowels will be partially dictated by the common dowel and/or pull-out mechanism behavior and partially by the a-posteriori behavior of the installed anchor. The maximum (normal or shear) strength, which can be transferred by such a steel component, will be smaller than the forces that can be transferred through the portion of the rebar that is fixed into any side of the interface.

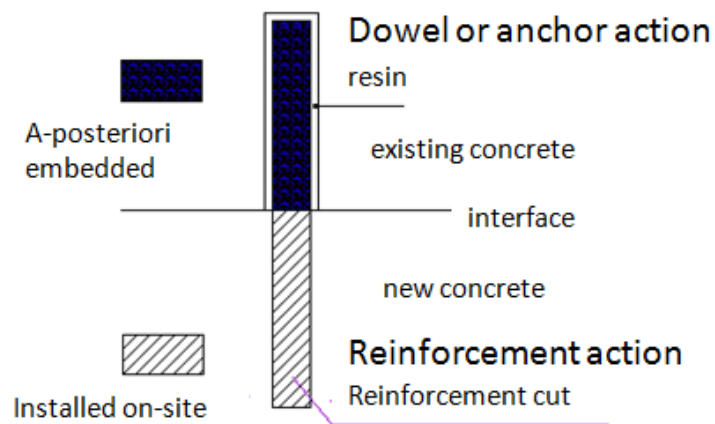

Figure C6.5: Rebar function during connection of new with existing concrete.

In case that rebars are used to connect old and new concrete, the section of the rebar that is embedded into concrete during casting behaves like conventional reinforcement.

Indicatively, in case of monotonic pull-out, the following simplifying expressions are given:

6.1.2.1 Rebar pull-out

- To calculate the required length of full anchorage or the maximum tensile force that can be transferred by the rebar for a given embedment length, the relationships of the Standard for the design of reinforced concrete works are applied.
- When it is necessary to calculate the mobilized stress " σ_s " of the rebar, due to its pull-out action, as a function of the normal slip " δ " imposed on the outer edge of the rebar, an appropriate analytical model shall be used, based on reliable data of a "local bond-local slip" constitutive law along the rebar.

The use of simplifying expressions from the literature is permitted.

a) When

$$\ell \geq \ell_b, \sigma_s = \frac{1}{\gamma_{Rd}} \sqrt{\frac{\delta}{d_b}} E_s f_{cd} \quad (C6.4)$$

where ℓ_b is the required anchorage length, as defined in § 8.4.3 of EC2.

and $\gamma_{Rd} = 1,1$ for $\sigma_s/f_{yd} \geq 0,70$ and $1,3$ for $\sigma_s/f_{yd} < 0,70$ (C6.5)

b) When the available anchorage length is $\ell < \ell_b$, then:

- In case that:

$$\frac{\sigma_s}{f_{yd}} \leq \frac{\ell}{\ell_b}, \text{ the previous expression applies}$$

- In case that $\frac{\sigma_s}{f_{yd}} \geq \frac{\ell}{\ell_b}$

$$\sigma_s = 2E_s \frac{s}{\ell} \cdot \left[1 + \frac{E_s}{f_{yd}} \left(\frac{2s}{\ell} - \frac{\ell}{2d_b} \frac{f_{cd}}{E_s} \right) \right] \quad (C6.6)$$

where σ_s and δ refer to the outer edge of the rebar (at its face).

The additional stress $\Delta\sigma_s$, can be calculated from the relationship:

$$\Delta\sigma_s = 2k f_{cd},$$

where, k is the ratio of the diameter of the hook drum to the diameter of the rebar and f_{cd} is the design value of the compressive strength of concrete.

c) If the rebar does not have sufficient length of straight anchorage but hooks (according to § 8.4.1 of the EC2) at its edge within the new concrete, then the tensile stress which the rebar transfers can be increased by the contribution of the embedding forces at the vicinity of the hook.

d) In cases of repeated or cyclic pull-out action, the (significantly increased) values of the resulting residual pull-out displacement, δ , shall be calculated by appropriate methods.

6.1.2.2. Dowel action of the reinforcing bars

a) Dowel strength

When the shear force is applied with eccentricity e with respect to the interface, the design value of maximum shear force, F_{ud} , which can be transferred by a rebar with a diameter d_b , can be calculated from the following relationship:

$$F_{ud} = \frac{1,30d_b^2}{\gamma_{Rd}} \left[\sqrt{1 + (1,3\varepsilon)^2} - 1,3\varepsilon \right] \sqrt{f_{cd}f_{yd}} \leq \frac{A_s f_{yd}}{\sqrt{3}} \quad (C6.7)$$

where:

$$\varepsilon = 3 \frac{e}{d_b} \sqrt{\frac{f_{cd}}{f_{yd}}} \quad (C6.8)$$

The design values of the steel yield strength and of the compressive strength of concrete are obtained as prescribed in Chapter 4, depending on whether the dowel is embedded within the old or the new concrete and depending on the data reliability level (in case of embedment into the old concrete) .

The design value of the maximum shear force, F_{ud} , which can be transferred by a rebar with diameter d_b , sufficient length (§ 6.1.2.2.c) and cover (§ 6.1.2.2b) can be calculated from the following relationship:

$$F_{ud} = \frac{1,30d_b^2}{\gamma_{Rd}} \sqrt{f_{cd}f_{yd}} \leq \frac{A_s f_{yd}}{\sqrt{3}} \quad (6.8)$$

where: A_s : the rebar diameter

f_{cd} : the design value of concrete compressive strength

f_{yd} : the design value of the rebar yield strength; γ_{Rd} is taken equal to 1,3.

When the interface that is penetrated by the rebar may be subjected to cyclic action, it is recommended to consider a reduced strength of the dowel as follows:

$$F_{ud} = 0,65d_b^2 \sqrt{f_{cd}f_{yd}} \leq \frac{A_s f_{yd}}{\sqrt{3}} [\text{mm, MPa}] \quad (6.9)$$

b) Minimum cover

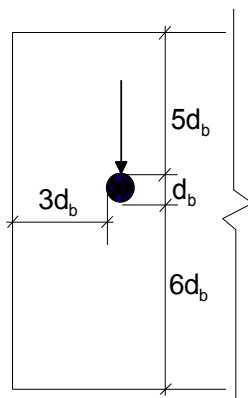

Figure C6.6: Definition of dowel cover

It is possible to reduce the extent of dowel cover only under specific and controlled conditions, such as the deliberate provision of suitable reinforcement within the new concrete (either in the form of dense rebar grid, or in the form of stirrup) almost in contact with the dowel and close to the interface (at a distance at maximum equal to twice the diameter of the dowel). Relevant data for reduced cover can be found in the literature.

In the absence of more accurate data the following may be taken into consideration:

It shall be ensured that the dowel mechanism fails after yielding of the dowel and simultaneous local failure that is due to concrete crushing beneath the rebar. The desirable mode of failure is ensured when the cover of the rebar with diameter d_b (in the direction of loading and perpendicular to it) is as a minimum equal to the following values:

- Along the loading direction:
Minimum front cover = $6d_b$
Minimum back cover = $5d_b$
- Perpendicular to the direction of loading:
Minimum lateral cover = $3d_b$

c) Spacing between successive dowels

If case of dowels that are arranged in a series, the net spacing between successive dowels shall be at least equal to five times the diameter of the dowel.

d) Dowel length

To enable the transfer of the shear force that results from either eq. (6.8) or (6.9) by the rebars, the length of the latter that is embedded within the concrete shall be at least equal to eight times their diameter.

When the embedment length cannot meet this requirement, then the maximum force that the dowel can transfer is reduced as compared to the one that is calculated from eq. (6.8) and

(a) The minimum embedment length can be taken equal to six times the diameter of the dowel, for which the dowel strength is derived from eq. (6.8) and (6.9) multiplied by a reduction factor of 0.75.

(b) For an available embedment length between $6d_b$ and $8d_b$, linear interpolation can be made.

It is recalled that the slip of an interface on which a side-to-side dowel is acting, is twice the displacement d , of the dowel head, conceived as unilaterally embedded.

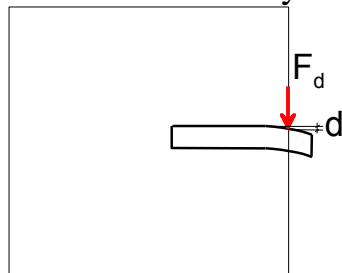

Figure C6.7: Dowel deformation

When more accurate data are not available, the diagram of Figure (C6.8) can be used, namely:

(a) For values of imposed relative slip that are lower or equal to 10% of the value that corresponds to the dowel strength, the relationship between slip and mobilized resistance is linear.

(b) For values of relative slip between $0,005 d_b$ and $0,05$

(6.9).

e) The resistance of the dowel that is calculated through eq. (6.8) or (6.9) is mobilized for an interface displacement equal to $0,05 d_b$.

When the relative slip that is permitted to occur along the interface is lower than that corresponding to the dowel strength, the dowel resistance shall be taken appropriately reduced.

d_b , the relationship between slip and the dowel action resistance can be calculated from the following relationship:

$$d = 0,1d_u + 1,80d_u \left[\left(\frac{F_d}{F_{ud}} \right)^4 - 0,5 \left(\frac{F_d}{F_{ud}} \right)^3 \right]$$

(C6.9)

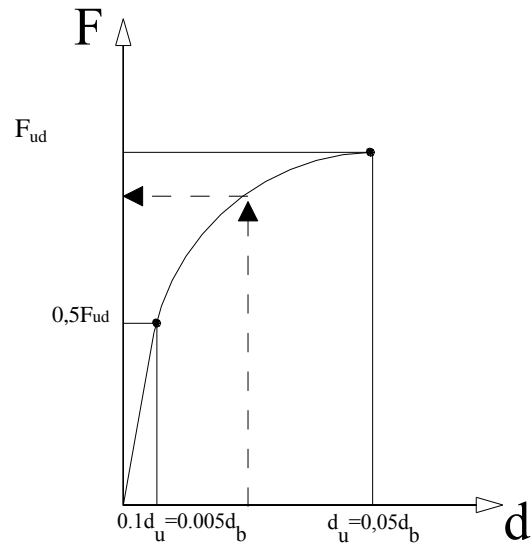

Figure C6.8: Constitutive law for the dowel behavior with sufficient concrete cover (also see eq. 6.10).

f) Interaction between dowel and pull-out mechanism

When the rebars have sufficient anchorage length

on both sides of the interface and are simultaneously subjected to tension and shear, it is generally impossible to develop their maximum strength against both pull-out and dowel action. The maximum shear force or the maximum pull-out force that the rebars can transfer may be calculated from the following formula, taking into account the cyclic slip:

$$\left(\frac{N_{Sd}}{N_{ud}}\right)^{3/2} + \left(\frac{F_{Sd}}{F_{ud}}\right)^{3/2} = 1 \quad (6.10)$$

where: N_{Sd} and N_{ud} is the effective tensile action and the maximum pull-out resistance respectively, F_{Sd} and F_{ud} is the effective shear force and the maximum dowel strength respectively.

In the usual case of short dowels (but in any case longer than $6d_b$), it is deemed that the dowels can only function is shear. Their limited capacity to resist axial tensile stresses can be neglected when it does not lead to unreliable results.

6.1.2.3. Design of embedded components

Given the sensitivity of the resin to moisture and high temperatures, proper care shall be taken to protect such components from the environment, as well as against high temperatures, the latter resulting from fire or during welding of another steel component (plate, rod), see also "Recommended Technical Specifications for Retrofitting," PETEP, Technical Chamber of Greece, 2008).

Various materials are commercially available for bonding anchors or dowels to concrete. The Designer shall in principle follow the written instructions of the manufacturer as to the appropriate diameter of the hole to which the steel component is applied, as well as to the design value of the bond stress between the connecting material, the anchor and the surrounding concrete.

This paragraph refers to the design of anchors or dowels, which consist of pieces of ribbed steel reinforcing rebars and are attached to the old concrete through resins, after opening of the appropriate hole.

- a) Components subjected to tension
To be able to apply the general expressions that follow, the Designer needs to have the appropriate data regarding the connecting material that is used.

The maximum tensile force that an anchor

This condition is met when anchor debonding is avoided, according to the following §§ (ii) and (iii).

While the yield force of the anchor is directly proportional to its cross-sectional area, the force causing debonding is proportional to the diameter of the anchor. Therefore, it is recommended to use a larger number of smaller diameter anchors for transferring the imposed tensile force.

The characteristic bond strength and the appropriate coefficient γ_b , depending on the details and conditions of application, are reported in the certificate of the connecting material.

can safely transfer is smaller than the forces calculated in paragraphs (i), (ii) and (iii) below.

(i) *Anchor yielding*

Provided that sufficient embedment length of the anchor is available, the maximum tensile force that an anchor can resist is calculated using the following formula:

$$N_{yd} = A_s f_{yd} \quad (6.11)$$

where: A_s and f_{yd} : the cross-sectional area and yield strength of the anchor, respectively.

(ii) *Debonding between the anchor and the connecting material*

The maximum tensile force that an anchor can resist until debonding between the anchor and the connecting material is triggered, can be calculated using the following formula:

$$N_{bd} = f_{bk} \ell_e \pi d_b / \gamma_b \quad (6.12)$$

where: f_{bk} : the characteristic value of bond strength between the anchor and the connecting material

ℓ_e : the embedment length of the anchor with diameter d_b , and

γ_b : the partial safety factor for bond

(iii) *Debonding between the connecting material and the surrounding concrete*

Since the mechanical characteristics of the connecting materials are much higher than those of concrete, the maximum force that the anchor can resist for this particular mode of failure solely depends on the tensile strength of concrete.

In the absence of more accurate data, the partial safety factor γ_c may be taken as follows:

$$\gamma_c = \gamma_c' \gamma_{inst}$$

where,

$\gamma_c' = 1,8$ the partial safety factor for concrete in tension and

γ_{inst} a partial safety factor that depends on the quality of the anchor application control on-site:

$\gamma_{inst} = 1,0$ for high standard quality of application

$\gamma_{inst} = 1,2$ for normal standard quality of application

$\gamma_{inst} = 1,4$ for tolerable standard quality of application

During the preparation of the design study, the quality of implementation can be estimated based on the difficulty of accessibility (and quality control) as well as the resulting deviations from uniformity and quality (also see Chapter 4, § 4.5.3.2).

The resistance of anchors subjected to shear is not sensitive to the quality of their

The maximum force that the anchor can resist until the “anchor-resin” system is pulled-out, is calculated from the following relationship:

$$N_{cd} = 4,5\pi l_e \sqrt{\frac{f_{ck}}{\gamma_c}} \varnothing \quad [\text{mm,MPa}] \quad (6.13)$$

where: f_{ck} : the characteristic compressive strength of concrete within which the anchor is embedded,

\varnothing : the diameter of the hole in which the anchor is placed, not larger than $d_b + 5\text{mm}$,

l_e : the embedment length of the anchor,

γ_c : the partial safety factor for concrete.

b) Components subjected to shear

To calculate the maximum shear force that can be resisted by

implementation. Thus, no issue arises regarding the application of the additional factor γ_{inst} .

The maximum shear force that can be transferred along a reinforced interface is derived as the sum of the contribution of all the mechanisms activated. The shear force transferred by each mechanism is accounted for appropriately reduced in order to consider (a) the interaction of the mechanisms, (b) the fact that each mechanism mobilizes its maximum resistance for different value of relative slip along the interface and (c) the cyclic nature of slip.

In the absence of more accurate data and for the case of reinforcing bars that are well anchored at each side of the interface, it is permitted to take the following values into consideration with respect to the participation factors of the two mechanisms:

an anchor, the relationships of paragraph 6.1.2.2 can be applied, provided that they meet the construction requirements specified in this paragraph and that they satisfy the limitation regarding the diameter of the hole (§ 6.1.2.3iii).

6.1.3. Simplifying calculation of the shear force transfer through reinforced interfaces

The resistance against shear force, $V_{Rd,int}$, of a reinforced interface is calculated based on the analytical models of §§ 6.1.1.4, 6.1.1.5 and 6.1.2. The following practical method can be applied:

$$V_{Rd,int} = \tau_{Rd,int} b l \quad (6.14)$$

where: b and l are the width and length of the reinforced interface, respectively, and $\tau_{Rd,int}$ is the design value of the interfacial shear strength, calculated as follows:

$$\tau_{Rd,int} = \beta_D \tau_D + \beta_F \tau_{fd} \text{ [mm,MPa]} \quad (6.15)$$

where: β_D and β_F are the participation factors of dowel and the friction mechanism in the bearing capacity of the interface,

τ_D is the resistance of the dowel mechanism, as resulting from the force F_d (that is mobilized for the respective amplitude of the relative slip) divided by the area of the interface and,

τ_{fd} is the resistance of the friction mechanism, which corresponds to the respective relative slip considered.

The value of the participation factor of each one of the individual mechanisms depends on several factors, such as:

- The amplitude of the expected slip along the interface
- The diameter and length of the reinforcing bar that penetrates the

- For values of tolerable relative slip $s \leq 1,00\text{mm}$, $\beta_D=0,7$ and $\beta_F=0,4$.
- When the value of the expected relative slip is uncertain or when the external compressive force acting on the interface is almost zero, it is permitted to take into account the following conservative values of the participation factors: $\beta_D=\beta_F=0,5$.

Given the high strength of the strengthening and the connecting material (epoxy resin), compared to the tensile strength of concrete, the anchorage failure is expected to be due to the exhaustion of concrete f_{ctm} , as long as, of course, an adequate preparation of the interface is preceded.

In the absence of more accurate data, the required anchorage length, l_b , extended beyond the location of the last crack just before the anchorage (which is expected to be developed under the redesign loads of the strengthened member), may be calculated from the following relationship:

$$b_j t_j \sigma_{j0, \max} = \ell_b b f_{ctm} \quad (C6.10)$$

b_j and b is the width of the laminate or fabric and the width of the member section respectively,

t_j is the thickness of the laminate or fabric

$\sigma_{j0, \max}$ is the yield strength of the steel laminate or the tensile strength of the FRP fabric.

When the maximum pull-out displacement, δ_0 , at the location of the crack beyond which the strengthening component is anchored is given ($\delta_0=0,5w$, where w is the tolerable crack width), and for $b_j=b$, the maximum attainable anchorage stress is calculated by the following relationship:

$$\sigma_{j, \max} = \sqrt{2 E_j f_{ctm} \frac{\delta_0}{t_j}} \quad (C6.11)$$

where E_j is the Modulus of Elasticity the laminate or fabric. The corresponding required anchorage length is calculated as follows:

$$\ell_b = \sqrt{2 \frac{E_j}{f_{ctm}} \delta_0 t_j} \quad (C6.12)$$

interface

- The compressive strength of concrete
- The cyclic slip, etc.

6.1.4 Anchorage of steel laminates or FRP sheets or FRP fabric in concrete

When a steel laminate or an FRP sheet or an FRP fabric is used for flexural strengthening of a member, a sufficient length, l_b , shall be ensured to guarantee full bond and anchorage of the strengthening material (see § 8.2.1.3).

When the available anchorage length is less than the one required for full anchorage, the maximum stress that can be mobilized by the strengthening material shall be calculated explicitly.

When the laminate or fabric is subjected to repeated compression, its behavior towards detachment is not known.

In any area of a structural element where it is expected that the sign of the bending moment will be changed, bending strengthening with bonded FRP laminates or fabrics is not permitted.

6.2 Concrete confinement

6.2.1. Confinement through stirrups or continuous steel laminates

It is recalled that $(\sigma_2=\sigma_3)/f_{cd} \sim 0,5\alpha\omega_{wd}$ (where “ α ” is the confinement efficiency and “ ω_{wd} ” is the volumetric mechanical ratio of the stirrups or the confinement laminate), and that the effective confinement ratio, $\alpha\omega_{wd}$ is calculated according to the Standard for the design of reinforced concrete works. In the case of sections with different confinement reinforcement ratio along the two axes, the calculation of the mechanical characteristics of confined concrete is based on the smaller of the two confinement ratios.

The mechanical characteristics of concrete, when confined through steel stirrups may be calculated by the following relationships:

$$f_{cd,c} = (1 + 2,5\alpha\omega_{wd})f_{cd}, \text{ for } \alpha\omega_{wd} \leq 0,10 \quad (6.17)$$

$$f_{cd,c} = (1,125 + 1,25\alpha\omega_{wd})f_{cd}, \text{ for } \alpha\omega_{wd} \geq 0,10 \quad (6.18)$$

$$\varepsilon_{c2,c} = 0,002(f_{cd,c} / f_{cd})^2 \quad (6.19)$$

$$\varepsilon_{cu,c} = 0,0035 + 0,1\alpha\omega_{wd} \quad (6.20)$$

where:

$\alpha\omega_{wd}$ the effective confinement ratio

$\varepsilon_{c2,c}$ the normalized deformation that corresponds to $f_{cd,c}$

$\varepsilon_{cu,c}$ the normalized deformation that corresponds to $0,85f_{cd}$ measured on the decaying branch of the σ - ε curve of the confined concrete.

6.2.2. Other forms of confinement

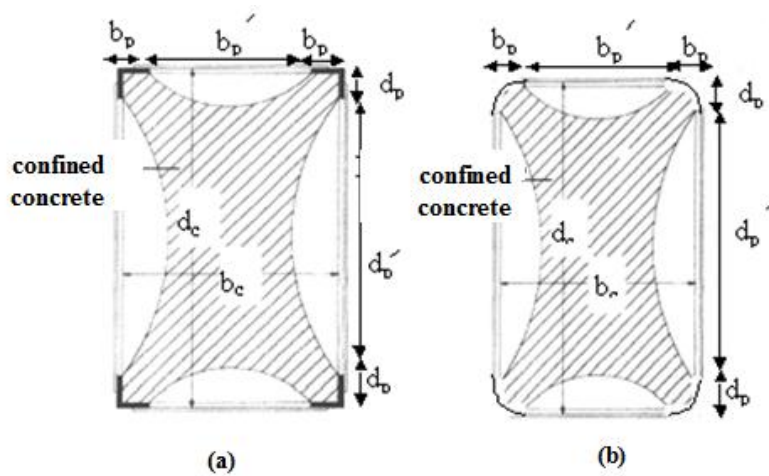

Figure C6.9 (a) Confinement using a steel cage
(β) Confinement using FRPs – corner rounding, see § 4.4.3.e

b_p and d_p are the corner laminates dimensions (commonly $b_p = d_p = 50$ mm), with a minimum thickness of 5mm.

It can be assumed that $\alpha_s = 0,9$

$$\text{and } \alpha_n = 1 - \frac{1}{3A_c} [b_c^2(1 - \beta)^2 + d_c^2(1 - \gamma)^2] \quad (6.13)$$

where $A_c = b_c \cdot d_c$ and

$$\beta = \frac{2b_p}{b_c}, \quad \gamma = \frac{2d_p}{d_c}$$

- a) **Implementing a metal tube**
In order to calculate the mechanical characteristics of confined concrete of cylindrical section, eq. (6.17) to (6.20), are used with $\alpha = 1.0$.
- b) **Implementing a steel cage**
In structural elements with rectangular cross sections that are strengthened using the steel cage technique, the confinement efficiency coefficient (α) is determined by taking into account the beneficial effect of the stiffness of the corner laminates.

6.2.3. Confinement using FRP

In case where confinement is achieved through FRPs, the mechanism fails upon failure of the confining composite material. A very steep decaying branch then follows which cannot be taken into account. As a result, $\varepsilon_{c2,c}$, i.e., the strain corresponding to the confined concrete strength, f_{cd} , is taken as the ultimate strain of the confined concrete. The effective transverse compressive stress $\sigma_2(=\sigma_3) \sim 0,5\alpha\omega_{wd}f_{cd}$, as well as the confinement ratio $\alpha\omega_{wd}$, are calculated as in the case of confinement through steel components, with the only difference that in the corresponding relationship, the available tensile strength of the FRP is introduced instead of the steel yield strength, appropriately reduced due to bending of the material at the corners of the structural member (see Chapter 4, § 4.5.3.2.) and perhaps according to the relationship 6.23.

The value of the multiple layers coefficient ψ , is estimated based on reliable data from the literature. In case of absence of sufficient relevant data, it can be taken as:

$$\psi = k^{-1/4}$$

where k is the number of FRP layers, when $k \geq 4$. Otherwise, it is taken as $\psi = 1.0$.

The rounding at the structural element edges shall be taken into account for determining the confinement coefficient α_n according to eq. C6.13, where b_p and d_p stand for the rounding length of sides b_c and d_c , respectively. (Figure 6.9 b).

The mechanical characteristics of confined concrete can be calculated through the following relationships:

$$f_{cd,c} = (1,125 + 1,25\alpha\omega_{wd})f_{cd} \quad (6.21)$$

where: f_{cd} is the design compressive strength of the existing concrete, as it is estimated after the investigation works prescribed in Chapter 3 of this Standard and the appropriate partial safety factors of Chapter 4 of this Standard (§ 4.5.3.1).

$$\varepsilon_{c2,c} = \gamma_{I\Omega\Pi} 0,0035 \left(f_{cd,c} / f_{cd} \right)^2 \quad (6.22)$$

where: $\gamma_{I\Omega\Pi} = 1,00$ (FRP with carbon fibers)
2,00 (FRP with grass fibers)

To calculate ω_{wd} , from which the effective confinement stress $\sigma_2 (= \sigma_3)$ is derived, a reduced value f'_j , of the FRP tensile strength is used, as follows:

$$f'_j = f_j \psi \quad (6.23)$$

where $k \leq 1,0$ is the coefficient expressing the influence of the number of the FRP layers.

The coefficient of confinement efficiency α is determined taking into account the beneficial effect of smoothing (rounding) at the edges of the element.

6.3. Lap splice strengthening through external confinement

The external confinement is activated mainly due to the transverse expansion caused by the relative slip of the overlapped rebars. An approximate activation mechanism of the external confinement in the area of a corner overlapped rebar is described in Figure C6.10: The relative slip of the lapped rebars induces the development of a slip crack of a width “w”. Blocking of this crack opening leads to the development of tensile stress “ σ_j ” within the material of the external confinement, which in turn leads to compressive stresses “ σ_N ” in concrete, in the area of the rebars, hence improving the bond conditions.

When the available lap splice length of rebars is insufficient, it is possible to improve the conditions of force transfer through external confinement.

The external confinement is ensured by steel components (thin jackets) or FRPs, and is calculated by reliable methods.

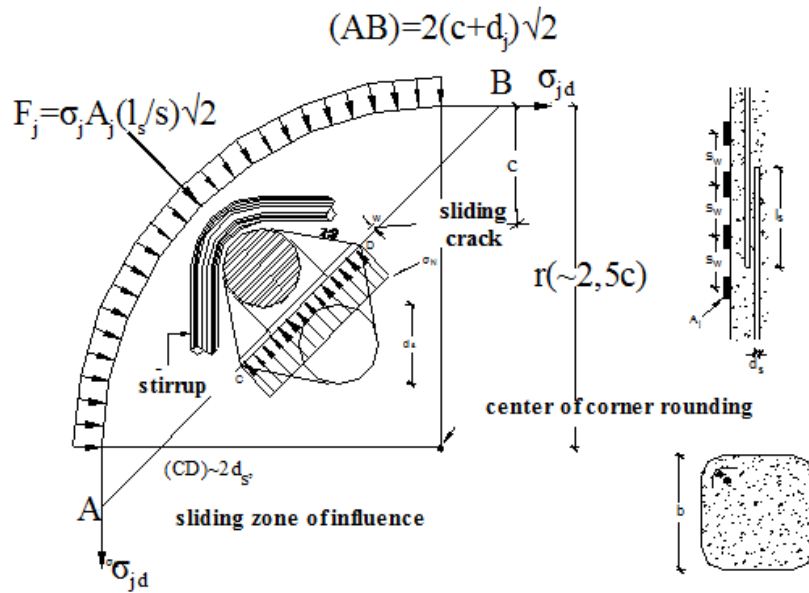

Figure C6.10: Activation of external confinement at the area of a corner, lapped rebar.

In case of corner rebars, and based on the above mechanism and the symbols illustrated in Figure C6.10, the extent of the required external confinement can be calculated using the following formula:

$$\left(\frac{A_j}{s_w d_s} \right) = 1,3 \left[\left(\frac{f_{sy}}{f_c} \right) : \left(2,2 \frac{s_d}{s_u} + 0,25 \right) \left(\frac{l_s}{d_s} \right) - 0,2 \left(\frac{c}{d_s} + 1,5 \right) \right]^2 :$$

$$: \left(\frac{w_d}{d_s} \right) \left(\frac{E_j}{f_c} \right) \left(\frac{f_{ctm}}{f_c} \right)$$

(C6.14)

where the ratio c/d_s shall not be set greater than 1.5
 s_u is the slip failure of the lapped rebars of the order of 2 mm
 s_d is acceptable relative slip of the lapped rebars, depending on the performance level (see Chapter 8)

while the mechanical properties of the materials are introduced with their identified mean values, without the use of any material safety factors. Moreover, the values of tolerable design deformations s_d (= relative slip) and w_d (= crack width) are appropriately selected depending on the performance level (see Chapter 8, § 8.1.2.3) adopted for the foreseen intervention. The value of the crack width, as a function of slip, is calculated from the relationship

$$w_d = 0,6s_d^{2/3} \text{ [mm].}$$

For the case of intermediate lapped rebars (i.e., at distance from the section corners), the extremely limited available information does not permit the formulation of a reliable model.

It is also permitted to use reliable closed-form expressions that provide the value of $\mu_{1/r}$ at the spalled section as a function of the section characteristics, the available maximum compressive strain of concrete (§ 6.2), and the axial force.

If new, well-anchored longitudinal reinforcement has been added to the structural element, e.g. in case of a jacketed column, then the relevant calculations of the ductility factor refer to the composite section. The mechanical characteristics of both the old and the new reinforcement are taken into account, together with the

6.4. Moment –curvature diagrams

- a) The moment-curvature diagram ($M-1/r$) of an R/C structural member section, which is subjected to a given axial force, is generated on the basis of the behavior models (of materials and sections) that are prescribed in the Standard for the Design of R/C Works.
- b) Curvature ductility, $M-1/r$, i.e., the ratio of the ultimate curvature to the yield curvature, is calculated using the moment-curvature diagram. Calculation of the ductility factor follows these steps:
 - The (yield) curvature of the section is calculated at the yield of the most highly tensed rebar for a given axial force.
 - The (ultimate) curvature of the section is calculated at failure of the compression zone of concrete. For this calculation, the mechanical characteristics of the confined concrete (§ 6.2.1) of the section core are taken into account, given the spalling of concrete outside of its core, for concrete deformation that exceeds a threshold value ($\epsilon_c > 0.0035$).

mechanical characteristics of the (old) weaker concrete.
The cross section of the core is calculated as prescribed in EC8 (§ 5.4.3.2.2.)

In case that new longitudinal reinforcement has been additionally provided, the comment of the preceding paragraph (ii) applies.

See Chapters 4,7, and 8.

When a more rigorous method is not available, plastic rotation may be estimated as follows:

(a) for the case of the assessment of existing structures according to the provisions of §7.2.4.1(b).

(b) after structural interventions (retrofitting, strengthening)

$$\vartheta_u = \mu \vartheta_y, \text{ with } \vartheta_{pl} = \vartheta_u - \vartheta_y$$

where ϑ_y , is defined as in §7.2.2(d) and

- The (ultimate) bending moment of the section is calculated; it shall not be less than the yield moment by more than 15%. If this requirement is not met, then the confinement reinforcement of the section shall be appropriately increased or external confinement shall be provided or the curvature ductility shall be taken equal to 1.00.
- c) When the ductility of the structural element is achieved by external confinement using steel components or FRP, the procedure described in paragraph (b) is followed with the modifications described below:
- The yield moment of the section is calculated as the moment that corresponds to the yield of the internal longitudinal tensile reinforcement, taking into account the mechanical characteristics of unconfined concrete.
 - To calculate the ultimate moment, the mechanical characteristics of confined concrete (a) are taken into account (§ 6.2).
 - When the confinement is achieved through a steel cage, jacket or FRP, the ultimate moment is calculated by taking into account the entire cross section of the member, given that the concrete spalling is impossible.
- d) If, after calculating the curvature ductility, methods correlating $\mu_{1/r}$ and local ductility factor m are available, it is possible to calculate the required confinement for a particular value of local and (subsequently) global ductility factor, m and q respectively.

6.5. Available plastic rotation

The calculation of the available plastic rotation angle (θ_{pl}) in a critical region of a structural member, shall take into account the maximum possible number of factors that affect:

- The post-elastic deformations that occur along the member (from the location of reinforcement yield to the support)
- The penetration of the yield and the pull-out of the tensile reinforcement of the section at the location of the support and
- The potential shear deformations along the member.

$\mu_{\delta} \cong \mu_{\delta}$, i.e., equal to displacement ductility, which can be approximately calculated, conservatively, by the following relationship:

$$\mu_{\delta} = (\mu_{1/r} + 2) / 3$$

where $\mu_{1/r}$ is the curvature ductility calculated according to §6.4.

Chapter 7 includes models for the calculation of the resistance (strength), stiffness, and post-elastic deformation capacity of structural elements – damaged or not.

When inelastic behaviour is controlled by flexure, then appropriate measures of F and δ are bending moment, M , and curvature $1/r$. When inelastic behaviour is controlled by shear, then appropriate measures are shear force, V , and angular (shear) deformation, γ . Because in RC elements flexural deformation coexist with shear deformation and

CHAPTER 7

ASSESSMENT OF BEHAVIOUR OF STRUCTURAL ELEMENTS

7.1 INTRODUCTION

7.1.1 Scope

The present Chapter 7 includes:

- a) The quantitative description of the behaviour of structural elements required by the various analysis methods specified in Chapter 5.
- b) Models for the calculation of the “capacity” of existing structural elements with (or without) damage. This capacity is expressed in terms of forces or deformations, for use with the basic safety inequality of Chapter 4. Models for repaired or strengthened elements are given in Chapter 4.

7.1.2 Basic characteristics of mechanic behaviour of structural elements – Definitions

7.1.2.1 Force-deformation curve “ F - δ ”

- a) The mechanic behaviour of a structural element, a critical region of a structural element or connection (joint) is described through a diagram of force “ F ” versus deformation “ δ ”. The type, direction etc. of “ F ” are chosen so that it accounts for most of the stress induced to the structural element, critical region or joint by

the rotations of end-sections due to anchorage slip of reinforcement bars beyond the end of the element, the most appropriate choice of F and δ are moment M and chord rotation " θ " at the ends of the element, where θ incorporates the sum of flexural and shear deformations, as well as the rotation of member ends due to reinforcement slip.

The loss of the structural capacity or resistance against vertical loads marks the final stage of element failure. Typically, this occurs at values of deformation δ well beyond those that cause the loss or substantial reduction of element resistance against seismic loading.

Usually, three full cycles are taken into account for each imposed deformation " δ ".

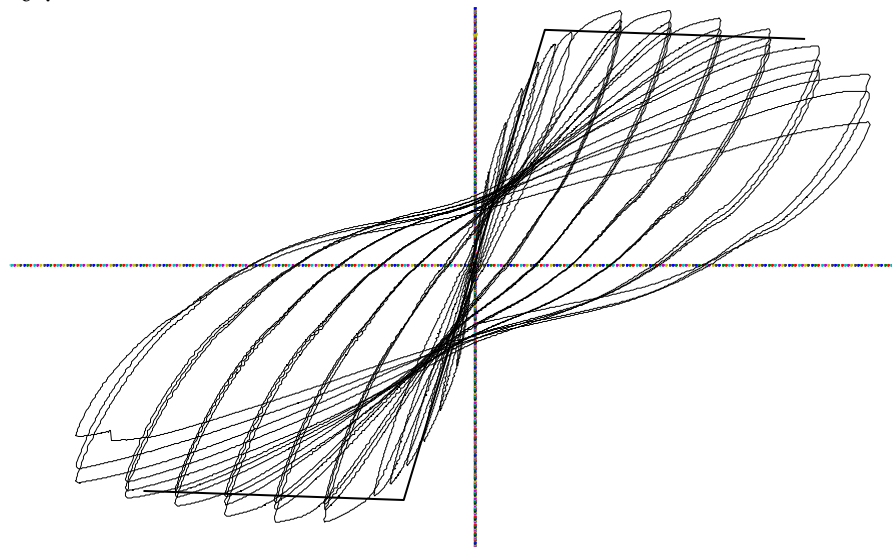

the seismic loading. The deformation, δ , is chosen so that in combination with the force, F , expresses the deformation energy of the element, critical region or connection.

- b)** For the purposes of the present Standards, it is assumed that the mechanic behaviour is described by the envelope of the degrading response, F , after full cyclic imposed deformation $\pm\delta$, until the loss of the capacity of the structural element, critical region or connection to carry gravity loads.

The simple rules for the calculation of the seismic response using pseudo-elastic methods (inelastic response spectra and the use of the behaviour factor, rule of equal displacements of an inelastic and an elastic system and its etc.) require a bilinear envelope of the total forces-deformations F - δ of the structure (i.e. base shear-top displacement curve), with the quasi-elastic branch extending up to yielding. The form of the F - δ curves of the individual models of elements or regions of the structure must be such so that eventually the F - δ curve for the whole of the structure is almost bilinear. This way, for reinforced concrete elements, the quasi-linear branch bypasses cracking and heads for the yielding of the element. (Particularly because the elements are already cracked due to prior actions, seismic and non-seismic, and moreover because the estimation of the nonlinear seismic response is not affected by whether the branch prior to yielding is assumed to be straight or multi-linear.

7.1.2.2 Quasi-elastic branch and yielding

- a) The approximation of the real F - δ curve with a multi-linear diagram is generally adequate for design purposes. The first linear branch extends from the origin of the axes until the conventional (or effective) “yielding” of the element (or critical region or connection of two or more elements), after which the F - δ curve may be assumed to be almost horizontal.

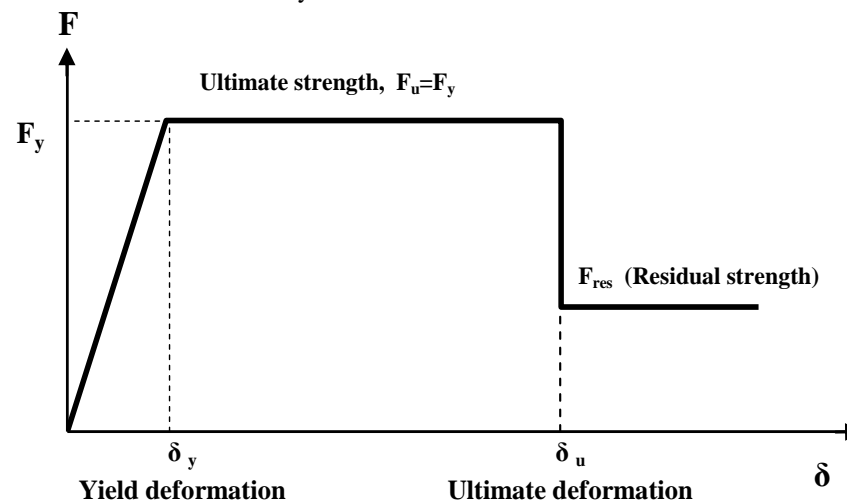

Thus, the following cases may be distinguished:

- (i) For an element failing in flexure with its end moment equal to M_u , it shall be taken
- $F_y = M_u$, in case F are expressed in terms of moments,
 - Or $F_y = V_{Mu}$ (shear force at the time of flexural failure) in case F are expressed in terms of shear forces.
- (ii) For an element failing in shear, i.e. when $V_u < V_{Mu}$, it shall be taken

- b) The yield resistance F_y may be taken equal to the ultimate resistance for the critical failure mode.

BODY

- $F_y = M_{Vu}$ (moment at the time of shear failure), in case F are expressed in terms of moments,
- Or $F_y = V_u$, in case F are expressed in terms of shear forces.

It is: $V_{Mu} = M_u / (\alpha_s h)$, where $\alpha_s = M / (V \cdot h)$ is the “shear ratio” of the region in question under the stress state examined.

It is noted that the meaning of the term “yielding” of a structural element is broader than that resulting solely by reinforcement yielding.

For reinforced concrete, the calculation of F_y and δ_y (thus also of the stiffness K) requires that the reinforcement of the element in question is known. For existing structures, the reinforcements are a given and in principle known, therefore the values of F_y , δ_y and K may be calculated using models given in § 7.2. For the case of repairs and strengthening, the values of F_y , δ_y and K may be calculated through an iterative procedure (design of the strengthening through trial and analysis cycles), see Chapter 8.

On average, and particularly for elements of existing buildings with a low ratio of longitudinal reinforcement, a 25% of the value of the stiffness of the uncracked element gives a realistic estimate of the quasi-elastic stiffness for the estimation of displacements and deformations.

If the reinforcement is unknown or undefined before the analysis, approximations of the quasi-elastic bending stiffness K as a function of the moment of inertia of the uncracked cross section, I_c , the modulus of elasticity of concrete, E_c , the axial force due to vertical actions, N (> 0 for compression), the area of the section, A_c , and “shear ratio” $\alpha_s = M / (V \cdot h)$ may be used as follows:

- For columns:

The value of deformation at yield, δ_y , should take into account all deformations during member yielding (flexural, shear, due to reinforcement slip).

- c) The quasi-elastic stiffness K used in the analysis of the structural system is defined and calculated by:

$$K = \frac{F_y}{\delta_y} \quad (1)$$

The calculation of the quasi-elastic stiffness, K , is based on mean values of material properties (see Chapter 4, § 4.4.1.4).

- d) The values of F_y , δ_y and K may be determined by ignoring the effect of the seismic loading on the structural element's axial force value, i.e. the value of the axial load due to vertical loads only (certainly, for the seismic combination).

$$K = 0.08(0.8 + \ln[\max(0.6; a_s)]) \left(1 + 0.048 \frac{N}{A_c} (MPa) \right) E_c I_c \quad (S1.a)$$

- For beams:

$$K = 0.1(0.8 + \ln[\max(0.6; a_s)]) E_c I_c \quad (S1.b)$$

- For rectangular shear walls:

$$K = 0.115(0.8 + \ln[\max(0.6; a_s)]) \left(1 + 0.048 \frac{N}{A_c} (MPa) \right) E_c I_c \quad (S1.c)$$

- For shear walls with L, T or C cross sections:

$$K = 0.09(0.8 + \ln[\max(0.6; a_s)]) \left(1 + 0.048 \frac{N}{A_c} (MPa) \right) E_c I_c \quad (S1.d)$$

The assessment of the inelastic structural response is not affected significantly by ignoring the positive slope of the post-elastic branch due to reinforcement strain hardening. However the post-elastic branch may be taken with a small positive slope for reasons of stability of the numerical analysis.

If an inelastic method of analysis of the seismic response is used (see §§ 5.7 and 5.8), the use of a negative slope of the F-δ curve may lead to numerical problems and erroneous results. Therefore, in these cases, an appropriate reduction of F_y is recommended, so that the more conservative horizontal post-elastic branch which results takes approximately into account the attenuation of the response under larger deformations also.

7.1.2.3 Post-elastic branch

- a) In cases where a certain reliable ductility of critical regions is expected, it is acceptable to assume that post-elastic branch of the F-δ curve is horizontal up to the failure deformation of the element, δ_u .
- b) In order to take into account a potential intense anticipated attenuation of the response with cyclic deformations or 2nd order effects, the post-elastic branch should be taken with a positive slope.

7.1.2.4 Deformation at failure and ductility.

The resistance F refers to stress due to lateral loads, such as stress induced by seismic loading. “Failure” due to significant drop of the resistance F is not necessarily accompanied with a reduction of resistance against gravity loads, with the exception of columns with high values of normalised axial load.

If chord rotation, θ , is used as δ , then the ductility factor $\mu_{\delta}=\mu_{\theta}$ involves chord rotations, i.e. drift of member ends. If curvature, $1/r$, is used as δ then μ_{δ} is the curvature ductility factor, $\mu_{1/r}$.

It is difficult to estimate the magnitude of the residual resistance F_{res} and of the deformation for which the resistance to gravity loads practically vanishes (see also § 4.4). A residual strength equal to 25% of the ultimate strength of the elements may be assumed only for purposes of modeling the response of the entire structure after the deformation at failure. In any case this is a failure state of interest only to performance level C, “Collapse prevention” and only for ductile elements.

The boundary between ductile and brittle behaviour is taken conventionally equal to 2.0 when it refers to the value of the available displacements/deformations ductility factor, μ_{δ} or μ_{θ} . When it refers to the value of the available curvatures ductility factor, $\mu_{1/r}$, the conventional boundary is taken equal to 3.0, see also §

As failure is defined the significant and often sudden reduction of resistance F under increasing monotonic or cyclic loading. Under this definition, a reduction of the value of the resistance by 20% may be considered as “failure”. As deformation at failure, δ_u , is defined the value that corresponds to a response F equal to 80% of the maximum. The value of deformation at failure, δ_u , also defines the plastic deformation capacity, though the plastic part of the deformation at failure, i.e. of $\delta_{u,pl}=\delta_u-\delta_y$ of an element, critical region or connection of elements.

The *deformation* δ may be expressed in a normalised form, through the deformation ductility factor, $\mu_{\delta}=\delta/\delta_y$. The ratio $\mu_{\delta u}=\delta_u/\delta_y$ is defined as the (maximum) value of the available deformation ductility factor.

7.1.2.5 Residual resistance

After deformation at failure, δ_u , the response of the element to seismic loading under increasing deformations δ decreases significantly, but does not vanish. This response may be considered to be almost constant up to the deformation that causes loss of resistance against gravity loads, and is called the residual resistance F_{res} . The value of the residual resistance is of interest only for purposes of modeling the inelastic response of ductile elements (see § 9.1.3 for the requirement of satisfaction of verification criteria and rules for all structural elements).

7.1.2.6 Ductile and brittle behaviour

- a) If the value of the available ductility factor μ_{δ} of a structural element, a critical region or a connection of elements exceeds a certain limit, then the behaviour is characterised as ductile, and thus the safety inequality shall be expressed in terms of

BODY

4.1.4 (iii).

Reinforced concrete elements which yield in shear before flexural yield (i.e. those for which $V_{Mu}=M_u/(\alpha_s h)$ is larger than V_u) are considered to have brittle behaviour.

Elements that yield in flexure before yielding in shear (i.e. when $V_{Mu}=M_u/(\alpha_s h)$ is less than V_u) may be considered to have ductile behaviour, except for elements having a low shear ratio (i.e. $\alpha_s=M/Vh<2$), the behaviour of which may be considered brittle, without calculation and verification of the value of the available ductility ratio.

If elastic analysis without a uniform behaviour factor q is used, then the safety inequality may be expressed in terms of forces, provided that the stress F is compared to the strength F_y ($\approx F_u$) of the element, after division of the former by an appropriate local ductility factor m , which is connected to the value of the available deformation ductility factor μ_δ of the element in question (see § 9.3.2).

deformations, δ . Otherwise, the behaviour is characterized as brittle, and thus the safety inequality shall be expressed in terms of forces, F , see Chapter 4.

- b) Elements with a ductile behaviour in principle according to the previous paragraph need to be verified in terms of forces against the possibility of shear failure due to the decrease of their shear strength under cyclic deformations according to § 7.2.4.2.

7.2 BEHAVIOUR (resistance, stiffness and deformation capacity) OF EXISTING UNDAMAGED OR NEW ELEMENTS

7.2.1 Force measure of element resistance at yield or failure

If the value of the axial force is high, failure of the concrete of the compression zone may precede the yielding of the tensile reinforcement, and the F - δ curve does not exhibit a clear yield point. In this case, instead of using an elasto-plastic F - δ curve resulting from the value of the flexural strength at yield according to the provisions of **EKOS 2000**, it is recommended to construct a diagram M -($1/r$) and fit to it an “equivalent” elasto-plastic F - δ curve, based on the equal areas rule.

- a) The resistance at yield F_y may be taken equal to the ultimate strength (for reinforced concrete as calculated according to the provisions of **EKOS 2000**), however using mean values of material properties instead of their design values, and in any case under the conditions of Chapters 3 and 4. Specially for the case the value of the resistance at yield is used for the verification of performance criteria for brittle modes of failure,

The effective (in tension) width of the slab at each side of the beam may be taken equal to the minimum of one fourth of the beam span, and half the distance until the first parallel beam.

The moment of resistance or yield moment of L- or T-beams in general is not affected by the value of the effective width for compression in the slab, but is sensitive to its value for tension in the slab.

The underestimation of the flexural strength of L- or T-beams by adopting a low value for the effective width of the slab in tension is unconservative, if it leads to the false conclusions that the beam yields flexurally before it fails in shear or that plastic hinges form in the beams first instead of columns.

That is, within the lap splice, the reinforcement ratio is taken doubled over the value applying outside the lap. Thanks to the end bearing of compression bars against a well-confined concrete, this assumption may be done for the base section of columns or shear walls where lap-splicing of ribbed bars with straight ends starts at floor level.

The limited experimental data which are available show that, practically, for straight bars with diameter d_b it may be assumed:

$$l_{b,min} = 0.3 d_b f_y / \sqrt{f_c} \quad (f_y, f_c \text{ in MPa}). \quad (S. 1)$$

If the lap length l_b is less than $l_{b,min}$ in the lap region, the “yield” stress of the bars in tension shall be taken equal to f_y multiplied by the ratio of l_b to $l_{b,min}$. However, for $l_b < 1/2 l_{b,min}$, generally lap splicing is ineffective.

its value is calculated using representative values of material properties and safety factors according to § 4.5.3 (see also Chapter 9).

- b) If the strength of linear elements is controlled by flexure, a lower boundary of F_y usually results from the value of the bending moment at yield of tensile reinforcement steel.
- c) In case of L- or T-beams and for tension in the slab, the reinforcement of the slab parallel to the beam within the effective (for tension in the slab) width should be included in the calculation of the moment at failure (or yielding), provided that they are adequately anchored beyond the end (support) of the beam.
- d) In areas of structural elements where the longitudinal reinforcements are spliced with lapping of their ends, the resistance (yield) moment M_y may be estimated based on the following assumptions:
 - i) For ribbed bars with straight ends lapped, within the lap splice it is allowed to consider both bars as compression reinforcement in case of adequate confinement.
 - ii) For ribbed bars with straight ends lapped, it is assumed that the tensile stress of the bars increases linearly from zero up to the yield stress, f_y , at a distance equal to the minimum lap length, $l_{b,min}$, which is necessary in order for the development of the full moment of resistance (or yield moment) of the section.
 - iii) For smooth bars with standard hooks, lap splicing of their ends for a straight length l_b at least $15d_b$ may be considered adequately effective for the transfer of the full yield stress of the tensile

reinforcements in cases where there is adequate confinement.

- e) If the tensile longitudinal reinforcements are extended beyond the end-section only for anchorage (i.e. top or bottom beam reinforcement of end-section near the support, bottom beam reinforcement at intermediate supports, top section of vertical element of top storey, connection of base section of vertical element with a foundation element etc.), the yield moment of the end-section in question may be estimated as follows:
 - i) For ribbed bars and straight ends, based on the previous paragraph (d) ii, where l_b and $l_{b,min}$ now refer to length of straight anchorage.
 - ii) For smooth bars with hooks, it is allowed to take the full yield moment provided that the bars extend beyond the end section at least by 10Φ .

7.2.2 Yield deformation of elements

- a) For the calculation of the deformations, the contribution of flexure and shear must be taken into account.
- b) The contribution of flexure to the deformation at yield may be estimated on the basis of the value of curvature at yield, $(1/r)_y$, which may be calculated based on the assumption of level sections and a linear σ - ϵ law for concrete and steel, and tensile strength of concrete equal to zero.
- c) In areas of structural elements where lap splicing of the longitudinal reinforcements occurs, the value of the curvature at yield may be calculated based on the assumptions (i), (ii) and (iii) of paragraph (d) of § 7.2.1.

Appendix 7A gives an analytic calculation procedure of curvature at yield for RC sections with a rectangular compression zone.

The length L_s is equal to the M/V ratio at the end section of the element, i.e. the distance of the end section from the point of contraflexure.

The slip of bars beyond the end section is proportional to: (i) the elongation of the steel at yield, and (ii) the required anchorage length. In the absence of more accurate data, the chord rotation at flexural yield, θ_y , may be estimated from the following expression:

- For beams or columns:

$$\theta_y = (1/r)_y \frac{L_s + a_v z}{3} + 0.001 \left(1 + 1.5 \frac{h}{L_s} \right) + \frac{(1/r)_y d_b f_y}{8\sqrt{f_c}} \quad (\text{S.2})$$

- For shear walls:

$$\theta_y = (1/r)_y \frac{L_s + a_v z}{3} + 0.0013 + \frac{(1/r)_y d_b f_y}{8\sqrt{f_c}} \quad (\text{S.3})$$

In Eq. (S.2) and (S.3), the 1st term expresses the contribution of flexural deformations, the 2nd term expresses the average shear deformations over a length L_s , while the 3rd term expresses the effect of anchorage slip of bars beyond the end section of the element (f_y and f_c in MPa)

The effect of lap splicing of bars with straight ends, may be taken into account as follows:

- The value of $(1/r)_y$ and of the moment of resistance (or yield) which is compared with the product $V_{R1}L_s$ as a criterion for the term $a_v z$ are calculated according to the provisions of paragraph (d) of § 7.2.1.
- If the lap splicing of straight bars is realised over a length l_b less than $l_{b,min}$, the 2nd term of Eq. (S.2) and (S.3) is multiplied with the ratio of the moment of resistance (or yield moment) which is calculated according to the provisions of § 7.2.1d (i) and (ii), to the value of this moment outside the lap splice. Also, in the 3rd term the values of f_y and ε_y is multiplied by the ratio of the lapping length l_b to $l_{b,min}$.

The few available experimental data for elements with longitudinal reinforcements consisting of smooth bars, show that Eq. (S.2) – mainly – and (S.3) approximate adequately the chord rotation at flexural yield, θ_y .

- If the deformations “ δ ” refer to the total length $L_s = \alpha_s h$ at the end of a structural element (i.e. when chord rotations, θ , are used as δ), then during flexural yielding, the part of θ_y due to flexure may be taken equal to $(1/r)_y(L_s + a_v z)/3$, where the term $a_v z$ expresses the effect of the “tension shift” of the bending moment diagram, with a_v equal to 1 if the value of the shear force V_{R1} , which causes diagonal cracking of the element is less than the value of the shear force during flexural yielding $V_{Mu} = M_y/L_s$, or 0 otherwise; and z is the length of the internal lever arm.

The contribution of the rotation of the end section due to bar slip beyond the end section needs to be added to the above value.

The contribution of shear deformations also need to be added to θ_y .

If there is lap splicing within a structural element starting or passing through its end section, then the effect of the lapping to θ_y (as composed from the contributions of the flexural and shear deformations and the rotation of the end section due to bar slip beyond this section) needs to be taken into account.

BODY

The effect of potential deficient anchorage of tension reinforcement beyond the end section to the values of $(1/r)_y$ και θ_y may be taken into account by the application of the rules of the above paragraph for elements with lap splices within their length, with l_b now being the anchorage length of the bars beyond the end section of the element.

Eq. (2) may be applied for the calculation of the effective stiffness even when shear failure of the element happens before flexural yield of its end.

The calculation of the stiffness according to Eq. (2) through M_y , θ_y may be based on a constant value of L_s , as follows:

- For beams connected with vertical elements at both ends, L_s may be taken equal to half of the clear span of the beam;
- For beams connected with a vertical element only at one end, L_s may be taken equal to the total clear span of the beam;
- For columns, L_s may be taken equal to half of the clear height outside of beams with which the beam is connected rigidly within the plane of bending considered;
- For shear walls, L_s may be taken different in each floor, equal to half of the distance of its base section at each floor until the topmost section of the wall.
-

- e) If the tension reinforcement is extended beyond the end section simply for anchorage according to paragraph (e) of § 7.2.1 over a length which is not adequate for the development of the full moment of resistance (or yield) M_y according to paragraph (e) of § 7.2.1, then the effect of insufficient anchorage to the yield deformation of the element needs to be taken into account.
- f) If the shear strength of the element, V_R , is less than the value of the shear force at the time of yield, $V_{Mu}=M_y/L_s$, then yielding is controlled by shear, so the deformation at yield is calculated as the product of $(1/r)_y$ or θ_y by $V_R L_s / M_y$, depending on the nature of δ (as $1/r$ or θ).

7.2.3 Effective stiffness of reinforced concrete elements

The effective stiffness of an element with length L_s is equal to:

$$K = M_y L_s / 3 \theta_y \quad (2)$$

where M_y and θ_y are the values of moment and chord rotation, respectively, at yielding of the end section of the element.

The effective stiffness K of the total length of the element may be taken equal to the average of the two values calculated by Eq. (2) for the two end sections of the element. If these sections have a non-symmetric shape or reinforcement (i.e. different for positive or negative bending), then the effective stiffness may be taken as the average of the mean values of the values of K from Eq. (2) for the two senses of bending (positive or negative).

7.2.4 Deformations of reinforced concrete elements at failure

For the case of failure before spalling, the curvature at failure due to fracture of tensile steel is:

$$(1/r)_{su} = \frac{\varepsilon_{su}}{(1 - \xi_{su})d} \quad (S.4)$$

while due to failure of the concrete in compression is:

$$(1/r)_{cu} = \frac{\varepsilon_{cu}}{\xi_{cu}d}. \quad (S.5)$$

In Eq. (S.4) and (S.5), ξ_{su} and ξ_{cu} is the height of the compression zone during failure of steel and concrete, respectively, normalised to the effective depth d ; ε_{su} is the uniform fracture elongation of tensile reinforcement and ε_{cu} the failure strain of the extreme fibre in compression.

The failure strain of the extreme fibre of the confined concrete core ε_{cu} may be estimated as:

$$\varepsilon_{cu} = 0.0035 + 0.1\alpha\omega_w \quad (S.6)$$

where ω_w is the mechanical volumetric ratio of the confinement reinforcement and α the coefficient of confinement efficiency:

$$\alpha = \left(1 - \frac{s_h}{2b_c}\right) \left(1 - \frac{s_h}{2h_c}\right) \left(1 - \frac{\sum b_i^2}{6b_c h_c}\right) \quad (S.7a)$$

where s_h the (net) stirrup spacing, b_c and h_c the dimensions of the concrete core (with $h_c \leq 1.5 \div 2.0 b_c$) and b_i the (roughly equal) distances between longitudinal bars laterally restrained by a stirrup corner or a cross-tie along the perimeter of the cross-section.

Alternatively, the height of the compression zone within the confined core may be used in Eq. (S.7a) instead of h_c , so b_i shall be the distances between longitudinal

7.2.4.1 Deformations at *flexural failure*

a) Curvature of RC section at failure

The curvature of a reinforced concrete section at failure may be calculated by constructing a moment-curvature diagram for the section up to the “failure”, taking into account that the section may fail due to fracture of tension reinforcement or due to failure of the concrete in compression, and even (depending on the confinement of the compression zone) before or after spalling of the unconfined part of the section.

bars along the external perimeter of the compression zone, starting at the neutral axis.

If the stirrups are not closed inwards with hooks ($\geq 135^\circ$ at corners and $\geq 90^\circ$ between them), it is recommended that the confinement be neglected (i.e. α to be taken equal to 0).

The following expressions may be used as such, provided the reinforcements consist of deformed (ribbed) bars:

i) For the mean value of chord rotation at failure of beams or columns, designed and constructed based on post-1985 provisions on seismic design:

$$\theta_{um} = 0.016 \cdot (0.3^v) \left[\frac{\max(0.01; \omega')}{\max(0.01; \omega)} f_c \right]^{0.225} (\alpha_s)^{0.35} 25 \left(\alpha \rho_s \frac{f_{yw}}{f_c} \right) (1.25^{100} \rho_d) \quad (\text{S.8a})$$

where:

$\alpha_s = M/Vh$, the shear ratio;

ω, ω' : mechanical ratio of tension and compression reinforcement (the intermediate longitudinal reinforcement is considered tension reinforcement);

$v = N/bhf_c$: normalised axial load (b =height of compression zone);

$\rho_s = A_{sh}/b_w s_h$: geometric ratio of transverse reinforcement parallel to the direction of loading;

ρ_d : geometric ratio of any crosswise diagonal reinforcement.

b) Plastic chord rotation and total chord rotation

- i) **The available plastic chord rotation θ_u^{pl} of a critical region and the available total chord rotation θ_u at the end of a structural element must be calculated while taking into account all the parameters involved, and in any case treating all relevant sources of uncertainty towards the safe side.**
- ii) **Conservative analytical methods, acceptable by the international literature, may be used for the estimation of θ_u^{pl} .**
- iii) **The estimation of the value of the available plastic or total chord rotation of reinforced concrete elements based on geometrical and mechanical data of the elements and their reinforcements is possible through empirical expressions or tables.**

For the mean value of the plastic part of the mean chord rotation at failure of the element:

$$\theta_{um}^{pl} = \theta_u - \theta_y = 0.0145 (0.25^V) \left[\frac{\max(0.01; \omega')}{\max(0.01; \omega)} \right]^{0.3} (f_c)^{0.2} (\alpha_s)^{0.35} 25 \left(\frac{\alpha \rho_s f_{yw}}{f_C} \right) \left(1.275^{100 \rho_d} \right) \quad (S.8b)$$

with the chord rotation at yielding, θ_y , according to Eq. (S.2) and (S.3).

Normally, the verification of available chord rotations of each element (§7.2.4.1) is made using values of axial force and shear ratio which develop gradually under the loads considered for the construction of the resistance curve of §5.7.3.4.

As a simplification, it is allowed to carry out the verifications for each element using values of axial force and shear ratio that occur at the moment of the critical displacement of the structure.

Regarding axial force, only for the case of low rise buildings for which the seismic action does not usually induce a variation of the axial forces of vertical elements, it is allowed to use the value of axial force due only to the vertical loads of the seismic combination.

Regarding the shear ratio, and only for vertical elements, a constant value of the shear ratio may be used over the entire response, according to the Commentary of §7.2.3. A beam end is critical for flexural failure when the top flange is in tension. In that case, the shear span is calculated as the current M/V ratio at the support. Only when the bottom flange is in tension, the constant value defined in the Commentary of §7.2.3 may be used for the calculation of the shear ratio.

- ii) For shear walls designed and constructed according to post-1985 seismic provisions, the 2nd term of Eq. (S.8a) needs to be multiplied by 0.58 (the coefficient becomes 0.009), while the 2nd term of Eq. (S.8b) needs to be

multiplied by 0.56 (the coefficient becomes 0.008).

- iii) For elements with deformed bars designed and constructed according the pre-1985 rules applying in Greece, the values calculated based on (i) and (ii) above need to be divided by 1.2. If the longitudinal reinforcements of the element consist of plain (smooth) bars, then the following paragraph v applies.
- iv) If the element is a column or shear wall the base section of which is the beginning of a lap splice with length l_b , then the plastic part of the chord rotation at failure of the element may be calculated according to Eq. (S.8b) (for the case of shear walls, the coefficient 0.0145 becomes 0.008, and furthermore in case it was designed/constructed according to pre-1985 seismic provisions the coefficient is further divided by 1.2) with application of the provision of § 7.2.1 (i) (d) (i.e. with a value of ω' doubled over its value applying outside the lap splice) and with multiplication of the right part of Eq. (S.8b) by $l_b/l_{bu,min}$ with:

$$l_{bu,min} = \frac{\Phi f_y}{\left(1.05 + 14.5\alpha_1\rho_s \frac{f_{yw}}{f_c}\right)\sqrt{f_c}} \quad (\Sigma.9)$$

where f_c , f_y , f_{yw} are the representative values of material properties in MPa, with material safety factors according to § 4.5.3, and ρ_s as defined for Eq. (S.8a), and

$$\alpha_1 = \left(1 - \frac{s_h}{2b_c}\right)\left(1 - \frac{s_h}{2h_c}\right)\frac{n_{restr}}{n_{tot}} \quad (\Sigma.7\beta)$$

where s_h , b_c , h_c as defined for Eq. (S.7a), n_{tot} is the total number of spliced longitudinal bars along the perimeter of the section and n_{restr} the number of aforementioned bars restrained by a stirrup corner or cross-tie.

- v) For elements with plain (smooth) reinforcements designed and constructed according the pre-1985 rules applying in Greece, the mean value of the

BODY

chord rotation at failure, θ_{um} , is calculated as the 95% of the value resulting from the previous paragraphs (i) through (iii). If, moreover, the element is a column or shear wall the base section of which is the beginning of a lap splice with length l_b equal to at least $15d_b$, then the mean value of the chord rotation at failure, θ_{um} , is calculated as the result of Eq. (S.8a) (taking into account paragraph ii for shear walls) multiplied by $0.016(10+\min(40, l_b/d_b))$, resulting to a reduction factor 0.8 if $l_b \geq 40d_b$ (which is equal to $0.95/1.2=0.8$, which results according to paragraph iii in combination with the this paragraph v.

- vi) The above paragraphs (i) through (v) refer to the mean values of the total and plastic part of the chord rotation at failure. The mean value minus one standard deviation of the chord rotation at failure is approximately equal to 65% of the value given by Eq. (S.8a), or the sum of the result of Eq. (S.8b) with those of Eq. (S.2) or (S.3) for the chord rotation at yield. The mean value minus one standard deviation of the plastic part of the chord rotation at failure is approximately equal to 55% of the value given by Eq. (S.8b).

Appendix 7B gives the mean value of the total and the plastic part of the chord rotation at failure, in relevant Tables.

7.2.4.2 Deformation during *shear* failure

- a) If the element fails due to shear before flexural yield, i.e. if $V_R < V_{My}$, then the plastic chord rotation after exhaustion of the shear strength of the element may be taken equal to 40% of the corresponding chord rotation at flexural yield, θ_y , according, to §7.2.2.

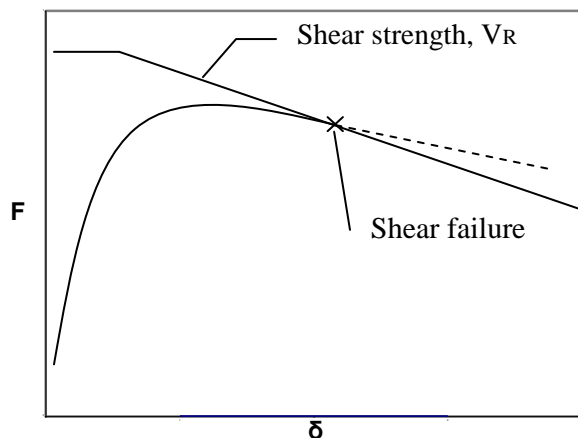

The degradation of shear strength with cycling loading is caused by a combination of mechanisms, such as:

- i) **The grinding of crack surfaces and the degradation of the interlocking mechanism of aggregates**
- ii) The widening of cracks over the accumulation of inelastic deformations (elongation) of stirrups, the attenuation of bond stresses along them due to cyclic loading, as well as the subsequent additional weakening of the interlocking mechanism of aggregates
- iii) The weakening of dowel action (of the longitudinal bars) with cyclic loading, and
- iv) The development of side to side flexural cracks with cyclic loading, and the reduction of shear resistance of the compression zone.

Normally, the verification of the shear strength of each element is carried out with values of axial force and shear ratio which develop gradually under the loads taken into account during the construction of the resistance curve of § 5.7.3.4.

As a simplification, it is allowed to carry out this verification for each element using the values of axial force and shear ratio during the critical displacement of the structure.

Regarding the axial force, only for the case of low-rise buildings for which

- b) *During the post-elastic cycles, the gradual degradation of the shear resistance V_R may lead to shear failure even in the case where initially $V_R > V_{Mu}$. In order to take this possibility properly into account it is required to estimate this degradation of V_R as a function of the imposed deformations ductility factor required for the design, $\mu_\delta = \mu_0 = \theta_u / \theta_y$, where θ_y is according to § 7.2.2, and θ_u is according to § 7.2.4.1(b).*

seismic loading typically does not induce a variation of axial forces of vertical elements, it is allowed to use the value of axial force due to vertical loads only.

Regarding the shear ratio, for vertical elements only it is allowed to use a constant value of the shear ratio during the entire response, according to the Commentary of §7.2.3. For beams, and end is generally critical for shear failure when the top flange is in tension. In that case, the shear span is calculated as the current M/V ratio at the support section. Only when the bottom flange is in tension, the constant value given in the Commentary of §7.2.3 may be used for the calculation of the shear ratio.

In the absence of a more accurate model, the attenuation of the shear strength is allowed to be estimated with empirical methods such as those of Appendix 7C.

7.2.5 Shear strength of joints

- a) At beam-column joints subjected to bending moments with opposite signs at opposite sides of the joint – and even more with alternating signs – the dangers of disintegration, exhaustion of bonding strength and loss of anchorage of the bars of elements which run through or are anchored inside the joint need to be taken into account. Moreover, such joints may be prone to shear failure depending on their reinforcement. Unreinforced joints are the most vulnerable.

(i) If beams are weaker than columns, i.e. $\sum M_{yb} < \sum M_{yc}$ ($\sum M_{yb}$ = sum

b) The maximum shear that can develop inside a joint

of yield moments of the beams that frame into the joint, ΣM_{yc} = sum of yield moments of the columns that frame into the joint, then:

- The beams induce a horizontal shear force V_{jh} to the joint:

$$V_{jh} \approx \sum M_{yb} \left(\frac{1}{z_b} - \frac{1}{h_{st}} \frac{L_b}{L_{bn}} \right)$$

(S.10)

where h_{st} is the story height, L_b and L_{bn} the theoretical and clear length of the beams respectively and z_b is the lever arm of internal forces of the beams.

- The mean shear stress inside the core of the joint is equal to $\tau_j = V_{jh}/b_j h_c$, where h_c : height of column cross section, b_j : width of the joint, which may be taken as the minimum of $\max(b_c, b_w)$ and $\min(b_c, b_w) + h_c/2$, with b_w and b_c the width of the beam and of the column along the horizontal direction perpendicular to h_c .

(ii) If $\Sigma M_{yb} > \Sigma M_{yc}$, then the shear stress is governed by the columns, and therefore:

- The vertical shear force in the joint is:

$$V_{jv} \approx \sum M_{yc} \left(\frac{1}{z_c} - \frac{1}{L_b} \frac{h_{st}}{h_{st,n}} \right) + \frac{1}{2} \left| [V_{g+\psi q,b}]_l - [V_{g+\psi q,b}]_r \right|$$

(S.11)

with z_c the length of the internal lever arm of columns and $V_{g+\psi q,b,r}$, $V_{g+\psi q,b,l}$ the shear forces of the beams to the right (r) and to the left (l) of the joint due to vertical loads that act at the same time with the seismic action.

- The shear stress in the joint is $\tau_j = V_{jv}/b_j h_b$, with h_b being the height of the beam.

Normally, the verification of Eq. (3) through (5) is carried out with axial force values which occur gradually under the loads considered when constructing the

is determined by the capacity of beams or columns that frame into the joint (whichever are weaker) to deliver shear into the joint through bond stresses along the outermost bars passing through the joint.

The shear force induced into the joint through the above mechanism can be assumed to cause a uniform shear stress in the joint, which is denoted by τ_j . Depending on the magnitude of τ_j and the mean normal compressive stress σ_c which develops at the core of the joint along the vertical direction, the following may occur:

- Diagonal tension cracking of the joint core (which does not have destructive consequences, if there are beams on both sides of the joint), or
- Failure due to diagonal compression.

c) Diagonal tension cracking of the core of

resistance curve of §5.7.3.4.

As a simplification, it is allowed to carry out this verification for each element using the values of axial force and shear ratio during the critical displacement of the structure.

Only for the case of low-rise buildings for which seismic loading typically does not induce a variation of axial forces of vertical elements, it is allowed to use the value of axial force due to vertical loads only.

unreinforced joints occurs when the principle tensile stress, i.e. the combination of: (i) the mean shear stress τ_j and (ii) the mean vertical compressive stress in the joint, $\sigma_c = v_{top} f_c$, (where v_{top} is the normalised axial force of the column above the joint), exceeds the compressive strength of concrete, f_{ct} , i.e. if:

$$\tau_j \geq \tau_c = f_{ct} \sqrt{1 + \frac{v_{top} f_c}{f_{ct}}}$$

(3)

- d)** Diagonal tension cracking of the core of joints reinforced with horizontal stirrups occurs when the principle tensile stress, i.e. the combination of (i) the mean shear stress τ_j and (ii) the mean vertical normal compressive stress in the joint, $\sigma_c = v_{top} f_c$, as defined above in paragraph **c**, and (iii) the mean horizontal compressive stress that develops in the core of the joint as a result of the confinement provided by the horizontal stirrups, exceeds the compressive strength of concrete, f_{ct} , i.e.:

$$\tau_j \geq \tau_c = f_{ct} \sqrt{\left(1 + \frac{\rho_{jh} f_{yw}}{f_{ct}}\right) \left(1 + \frac{v_{top} f_c}{f_{ct}}\right)} \quad (4)$$

where:

$\rho_{jh} = A_{sh}/b_j h_{jb}$ i.e. the total cross section A_{sh} of the horizontal stirrup legs parallel to the vertical plane of the stress τ_j , normalised to the area of the vertical cross section of the joint, $b_j z_b$, where the width b_j is the minimum of $\max(b_c, b_w)$ and

$0.5h_c + \min(b_c, b_w)$ (in the above expressions b_c and b_w are the width of the column and of the beam along the horizontal direction perpendicular to h_c , while the height z_b is the distance between top and bottom reinforcements of the beam)

- e) Failure of the core due to diagonal compression occurs if the principle compressive stress exceeds the compressive stress (as reduced by possible transverse tensile deformations) of the concrete. If the mean shear stress in the joint, τ_j , exceeds the value of τ_c given by Eq. (3) or (4), then it may be assumed that failure of the joint due to diagonal compression occurs when the value of τ_j exceeds the value:

$$\tau_j \geq \tau_{ju} = n f_c \sqrt{1 - \frac{v_{top}}{n}} \quad (5)$$

where: $n = 0.6(1 - f_c(\text{MPa})/250)$

the reduction factor of the uniaxial compressive strength due to transverse tensile deformations.

If, on the other hand, τ_j is less than τ_c given by Eq. (3) or (4), then it may be assumed that failure of the joint due to diagonal compression occurs when τ_j exceeds the value derived from Eq. (5) for $n=1$.

7.2.6 Estimation of uniform behaviour factor q

7.2.6.1 General

If the concept of the uniform or overall behaviour factor of the structure, q , is used as a base for the assessment or redesign, then

the value of q can be approximated based on the structural geometry, the distribution of resistances in the building as well as the reinforcement detailing of its elements.

In the absence of more accurate data, the q factor may be estimated according to § 4.6.

7.2.6.2 *Correlation of factor q and of total displacement and element displacements ductility factors, see Par. 4.2*

- a)** The value of the ductility factor q_{π} which modulates factor q ($q=q_v, q_{\pi}$), is linked to the total horizontal displacement ductility factor (referring to the top of the building or to the point of application of the total resultant horizontal seismic force), μ_{δ} , as follows:

$$q_{\pi} = \mu_{\delta} \quad \text{if } T \geq T_C, \quad (6a)$$

$$q_{\pi} = 1 + \frac{T}{T_C} (\mu_{\delta} - 1) \quad \text{if } T \leq T_C, \quad (6b)$$

where T is the fundamental period of the building in the direction considered and T_C the period at the beginning of the descending branch of the accelerations spectrum (i.e. at the end of the constant accelerations region).

- b)** The total displacements ductility factor, μ_{δ} , of the building can be translated to the local drifts or deformations (such as story drift, chord rotations of member ends etc) ductility factor, μ_0 , as follows:

- i) If the vertical elements of the building are strong enough so that the development of a soft story mechanism is prevented, and the distribution of the inelastic deformation demands is roughly uniform along the height of the building, then

$$\mu_{\delta} = \mu_0 \quad (7)$$

Eq. (6) apply for systems with a bilinear uniaxial force (base shear) – (top) displacement curve, i.e. for elastic stiffness equal to the secant stiffness (i.e. chord stiffness) at the generalised yielding of the system.

This condition may be assumed to apply when in the horizontal direction considered there are shear walls that carry at least 60% of the base shear (for elastic behaviour), or when at each floor the ratio $\Sigma(\Sigma M_{Rc})/\Sigma(\Sigma M_{Rb})$ of the sum of all moments of resistance of columns above and below the joints to the sum of the moments of resistance of beams that frame into these joints along the direction considered is greater than 1.4. These sums involve the projections of the moments of resistance perpendicular to the horizontal direction considered.

This requirement applies for elements for which the (reduced due to cyclic inelastic deformations) value of the shear strength, V_u , exceeds the value of the shear force V_{Mu} during flexural failure ($V_{Mu}=M_u/L_s$, with $L_s=M/V=\alpha_s \cdot h$ =shear span).

Usually, only the base sections of vertical elements need to be examined; the most critical element being the one which bears the most part of the base shear.

The effect of damage to the mechanical characteristics of the element, critical region or connection of elements may be estimated through reduction factors r_K , r_R , $r_{\delta u}$, applied on K , F_y and δ_u , respectively, of the undamaged element. Generally, the values of r_K , r_R , $r_{\delta u}$ follow the relationship:

$$r_K \leq r_R \leq r_{\delta u} \quad (S.12)$$

and range from 1.0, corresponding to the virtually undamaged state, to 0, which corresponds essentially to a state of failure of the element.

Indicative values of reduction factors r are given in Appendix 7Δ.

- ii) If the development of a soft story mechanism at a floor of the building (with height H_{op}) is likely, then:

$$\mu_{\delta} = \mu_0 \frac{H_{op}}{H_{tot}} \quad (8)$$

where H_{tot} is the total height of the building and H_{op} is the height of the story where the development of a plastic mechanism is likely to occur.

- c) If the inelastic behaviour of the elements is controlled by flexure, then the available value of μ_0 may be estimated as the minimum value among the ratios θ_u/θ_y at the ends of all elements which take part in the plastic mechanism (where θ_u and θ_y are the chord rotations at failure and yield, respectively, according to §§ 7.2.4.1b και 7.2.2c)

7.3 BEHAVIOUR OF UNREPAIRED DAMAGED ELEMENTS

- a) It should be taken into account that generally the F - δ curve of a structural element, critical region or connection of elements that has sustained damage and is subjected to stress again without first being repaired or strengthened, is degraded (i.e. it has smaller F coordinates) and exhibits larger yield deformation, δ_y , and smaller failure deformation, δ_u , compared to the initial (undamaged) state.

These differences, compared with the F - δ curve of the element, critical region or connection of elements before damage, may be expressed quantitatively as a reduction of the quasi-elastic stiffness, K , of the yield strength F_y , and the deformation at failure, δ_u . Generally, the reduction of the quasi-elastic stiffness is greater than the reduction of the yield force, while the decrease of the yield force is greater than the reduction of the deformation at failure. The reduction of the above stiffness, strength and deformation parameters is larger when yielding and/or failure is controlled by shear, and smaller when controlled by flexure.

The reduction of the above mechanical characteristics increases with the degree

An infill wall may be taken into account only when it is enclosed by reinforced concrete elements (i.e. is effectively confined by – or fixed to – elements of the frame at least along three of its sides and does not have many and/or large openings and is not prone to premature out-of-plane failure.

On existing or added infill walls, see also the provisions of Chapter 4 (§§ 4.5.3.1.d και 4.5.3.2.c, as well as Appendixes 4.1, 4.2 and 4.4), Chapter 5 (§§ 5.4.3.c, 5.4.4.b and 5.9) and Chapter 9 (§§ 9.3.1.a και 9.3.2.a, as well as Appendix 9A).

of damage (ranging from minor damage to total failure) of the structural element, critical region of connection of elements.

- b) Due to the inherent uncertainty which characterises the stiffness, strength and ultimate deformation of damaged elements, the estimated mean values of these parameters should be introduced in the calculations divided by a coefficient γ_{Rd} with values greater than 1 if the effect of these parameters is unfavourable, or less than 1, if favourable.

7.3 BEHAVIOUR OF INFILL WALLS

7.4.1 Unreinforced infill walls

- a) Infill walls do not carry vertical (gravity) loads, other than their self weight. Under earthquake load, they can be modeled as:

- either as a shear, orthotropic panel, with four “nodes”-hinges with the corresponding joints of the infilled frame,
- or, more simply, as an equivalent hinged diagonal brace in compression (in the sense of the seismic loading within the frame each time) with a given width b .

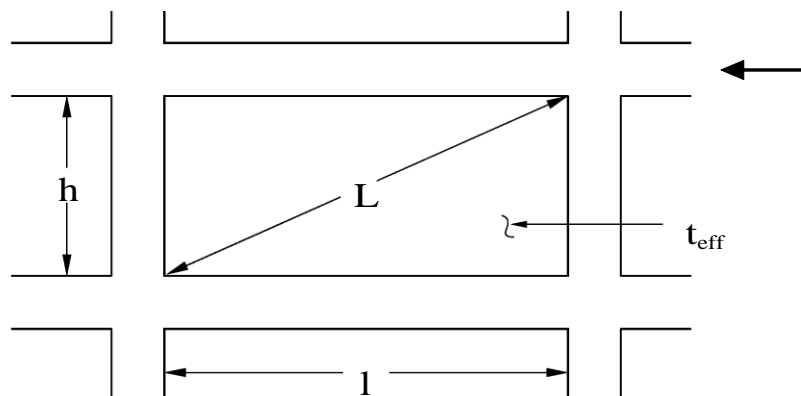

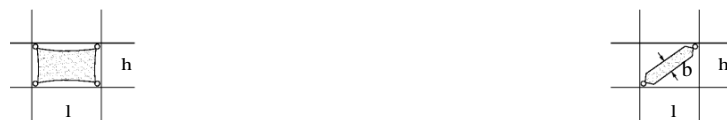

MODELING OF INFILL WALLS

If the diagonal brace starts and ends at joints of the frame, the use of a strut-tractor model along the two diagonals using bars with half the axial stiffness of that of a simple diagonal strut, practically results to the same load distribution to the structure except for the axial forces of some elements. Specifically, there are differences in the axial forces of perimeter columns, which are however small if compared to the axial forces due to vertical loads, so the differences may be neglected. In beams, the axial forces can generally be neglected and the differences are small anyway. The differences may not always be neglected when the struts/tractors end at an intermediate position of a beam (or column).

- b) Common existing unreinforced infill walls are checked in terms of forces or deformations and are (potentially) taken into account for performance levels A and B only (according to Chapter 9). For performance level C, they are not included in the model (and consequently they are not checked). However, according to the provisions of § 5.9, § e of Appendix 4.2 and Appendix 4.4, the potentially unfavourable effect of the infill walls (local or global) should always be checked and/or reduced. Finally, it is noted that according to § 5.4.3.c, generally it is not allowed to take or not take into account the infill walls selectively, i.e. for only some of the floors or for some positions only.
- c) The deliberately added reinforced masonry walls, or existing infill walls after strengthening (under the conditions of Chapter 8) may be taken into account also for performance level C, with verifications in terms of forces or deformations, as appropriate.

The branch following failure, and mostly the value of F_{res} , is of interest only for reasons having to do with more accurate modeling of the inelastic response of the entire structure, in connection with the requirement of satisfaction of verification

Specifically, it is allowed to take into account the residual (after failure) strength branch of the skeleton behaviour curve, with values of $\alpha=0.25$ and $\beta=1.5$, as for RC members (See Appendix 4.4. and § 7.1.2.5).

criteria and rules for all structural elements (see § 9.1.3).

Η επιρροή του μεγέθους και της θέσεως των ανοιγμάτων στην δυστημψία ή δυστένεια και στην φέρουσα ικανότητα των τοιχοπληρώσεων δεν προσομοιώνεται με απλά μέσα.

Ελλείψει λεπτομερέστερης διερευνήσεως για άοπλες τοιχοπληρώσεις, μπορούν να λαμβάνονται υπόψη τα ακόλουθα στοιχεία:

The effect of the size and location of openings in the axial or shear stiffness and bearing capacity of infill walls is not simple to model.

In the absence of more accurate investigation for unreinforced infill walls, the following may be applied:

- a) When there are two large openings near both sides of the panel, the infill wall is neglected.
- b) Where there is an opening located approximately at the centre of the panel with dimensions that do not exceed 20% of the corresponding panel dimensions, its effect to the characteristics of the panel may be neglected.
- c) When there is an opening, located approximately at the centre of the panel with dimensions that near or exceed 50% of the corresponding panel dimensions, the infill wall may be neglected.
- d) When there is an opening, located approximately at the centre of the panel with dimensions between 20% and 50% of the corresponding panel dimensions, then it is allowed to model the infill wall using two diagonal struts per panel. These struts shall start from the two extremities of the main diagonal of the panel and end near the middle of the beam above and under the panel, respectively. In this case, the effect of the struts to the beams' shear capacity needs to be taken into account.
- e) Two small neighbouring openings within a panel may be considered as one equivalent / uniform opening, circumscribed around them.

In case a more accurate calculation is not done, then the shear and compressive resistances of the infill may be reduced appropriately.

For the purposes of the present Standard, the reduction of the resistances may be done based on the slenderness, λ , of the infill, which is defined as the L/t ratio,

- d) When there are openings within an infill wall panel, its modeling must be modified appropriately, by checking to what extent the arrangement of the openings allow for shear panel behaviour or for the formulation of diagonal infill struts with such boundary conditions to allow for their participation in the lateral resistance mechanism of the frame.

During this check, it shall also be taken appropriately into account to what extent any type of opening is enclosed by tie beams or frames (or other reinforcing elements), horizontal and/or vertical (reinforced jambs and/or sills, lintels etc).

The decision about the effect of any type of openings on infill walls shall be taken based on the Engineer's justified judgement.

- e) It should be ensured, however, that unreinforced infill walls do not suffer premature out-of-plane failure.

where:

$L = \sqrt{l^2 + h^2}$ is the “clear” length of the diagonal of the wall panel; with l and h the “clear” width and height of the panel, and t is the “equivalent” thickness of the wall.

For wall panels with uniform thickness, then the “equivalent” thickness is taken equal to their total thickness.

In case of a two-layer (hollow) infill wall, consisting of two independent parallel walls with a gap between them, the calculation of the equivalent thickness shall take into account the geometry of the wall, the potential existence or absence of adequate transverse ties between the internal and external layers of the wall and the risk of premature failure of the most slender layer.

In the absence of more accurate data, for layers with thicknesses t_1 and t_2 , and inadequate transverse ties, as the value of the equivalent thickness may be taken as:

$$t_{\text{eff}} \approx 1/2(t_1+t_2). \quad (\text{S.13a})$$

Respectively, for full connection of the layers (see also EC6), the value of the equivalent thickness may be taken as:

$$t_{\text{eff}} \approx \sqrt[3]{t_1^3 + t_2^3} \approx 2/3(t_1+t_2). \quad (\text{S.13b})$$

In cases of simple contact with the surrounding frame along the perimeter, the respective reduction of the resistance of the infill wall is estimated as a function of slenderness as follows:

- i. When the value of the slenderness λ does not exceed 15, or practically when l/t or $h/t \leq 15$ (see Appendix 4.2/§ e), reduction of the resistance is not required.
- ii. When the slenderness of the infill wall is greater than 30, then the wall is neglected, i.e. its resistances in- and out-of-plane shall be taken practically equal to zero, except in cases its effect is unfavourable.
- iii. For intermediate cases and values of λ , the compressive (and, equivalently, shear) strength of the wall are multiplied by a reduction factor φ , as follows:

$$\varphi = 0.9 \frac{1}{e^{\frac{(0.0447\lambda - 0.063)^2}{0.9}}} \quad \text{or} \quad \varphi = 0.9 \frac{1}{e^{\frac{(0.0316\lambda - 0.063)^2}{0.9}}}, \quad (\text{S.14})$$

for $E_w \approx (500 \text{ or } 1000) f_{wc}$, respectively.

As a simplification, and for the purposes of the present Standard, the reduced

(F_{red}) strengths of unreinforced infill walls may be estimated based on the following diagram, which covers both cases of simple contact of the wall with the surrounding frame along its perimeter, and of effective confinement by the surrounding frame (after the restoration of possible horizontal settlement cracks below the beams):

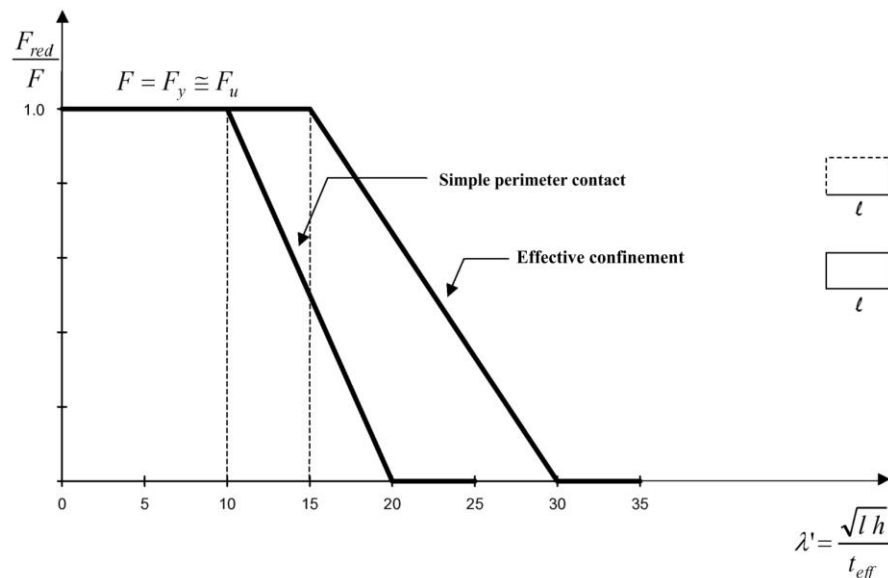

(Για συνηθισμένα φαντώματα τοιχοπληρώσεων: $\sqrt{l \cdot h} \approx 2/3 L$)

(For common infill wall panels: $\sqrt{l \cdot h} \approx 2/3 L$)

In the absence of more accurate data it is assumed that the following §§ g.1 and g.2 apply for performance level B, while for performance level A, resistances (shear or compressive) may be assumed to be 50% higher (i.e. $1.5 \cdot \overline{f}_{wv}$ and $1.5 \gamma_y$ or $1.5 \cdot \overline{f}_{wc,s}$ and $1.5 \varepsilon_y$, respectively).

- f) The mechanical characteristic of the infill walls are estimated based on the mechanical characteristics of the bricks and mortar (as derived according to the provisions of Chapter 3 of the present Standard), taking appropriately into account the method of masonry construction. Of course, the resistance of infill walls is also a function of the contact length between them and elements of the surrounding frame. In turn, this contact length depends on the magnitude of the imposed lateral displacement and the

In the absence of more accurate data, the following diagram may be used for performance level B:

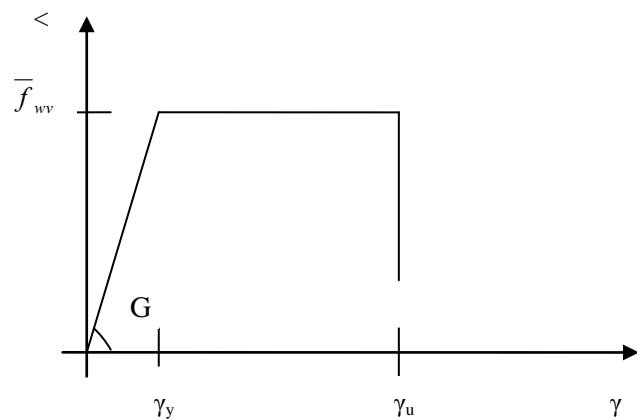

Shear stress-angular deformation diagram of unreinforced infill wall, with $\gamma_y \approx$

$$\left(\frac{l}{h} + \frac{h}{l}\right) \cdot (1.0 \div 1.5) \cdot 10^{-3} \text{ and}$$

$$\gamma_u \approx \left(\frac{l}{h} + \frac{h}{l}\right) \cdot (2.0 \div 3.5) \cdot 10^{-3}.$$

The choice of values of γ_y and γ_u must be in correspondence with the prescribed value ranges, i.e. for small γ_y , γ_u is also small, etc.

The value of the shear stress of the infill panel is obtained by dividing the shear

damage.

Thus, the geometric properties that form the resistances, and eventually the resistances themselves are estimated depending also on the intended performance level (A or B), i.e. depending on the displacements and the acceptable degree of damage for infill walls.

g.1) When the infill wall is modeled as a shear panel, its behaviour is described by an appropriate shear stress-angular deformation diagram, taking into account the effect of cyclic loading, as well as the favourable role of in-plane confinement of the wall by the surrounding frame.

force by the total horizontal area of the panel (on equivalent thickness, see the commentary of previous § e).

The verification of the panel's shear resistance is made based on the mean shear strength of the infill wall. The shear strength may be calculated according to the provisions of EC6.

For the calculation of the mean shear strength of the wall, the presence of a vertical (however small) compressive stress, σ_0 , is required.

This stress results from:

- i) the vertical loads transferred to the infill wall after its construction, provided there is effective confinement of the infill wall by the beam above it, and
- ii) the self weight of the infill wall.

Given that the verification against shear force is critical in the region around the centre of the infill wall, the compressive stress at middle of the height of the wall, which is derived from the self weight of the wall at that level, may be taken into account.

The values of the angular deformations in the diagram above are greater than the ones that are usually permitted for unreinforced infill walls. This is due to the fact that the frame that surrounds the panel provides (certainly under conditions) confinement to the wall, thanks to which the values of the critical deformations are increased significantly.

See previous § a on the option of modeling infills using two crosswise diagonals (in principle as a strut-tractor model).

This width depends effectively also from the acceptable degree of damage, i.e. the performance level (A or B), see commentary in the beginning of this paragraph.

In the absence of other more accurate data, the following approximations may be used:

- i) With respect to the compatibility of deformations and forces (stresses):

- g.2)** When the infill wall is modeled as an equivalent (to the shear panel, see above) diagonal strut, the parameters which are involved in the design and the calculations shall be estimated appropriately, as follows:
 - The thickness **t** of the diagonal strut shall be estimated in the same manner as for the shear panel model,
 - The width **b** of the diagonal strut shall be estimated on the basis of the equivalence and deformation and force (stress) compatibility, while
 - The mean compressive strength of the infill wall along the direction of the diagonal, $\bar{f}_{wc,s}$, may be estimated taking into account both the mean compressive strength along the vertical direction, as well as its reduction due to transverse (horizontal) tensile stresses.

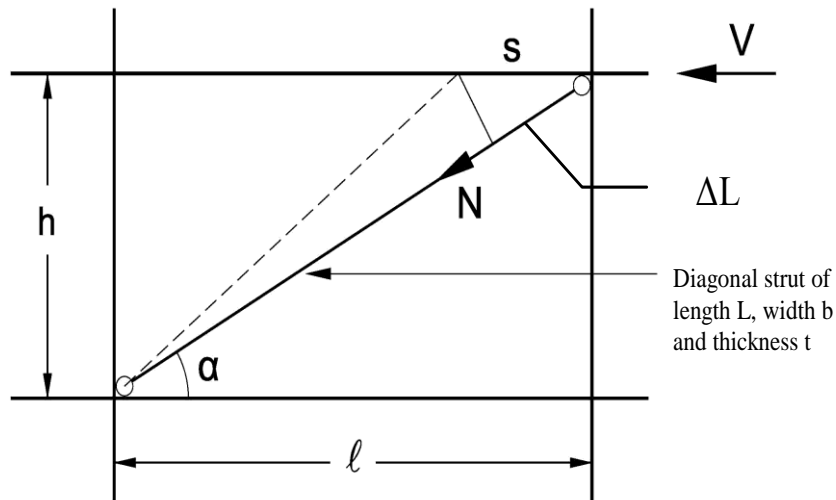

- Analysis of forces

$$N = V \cdot \cos \alpha \quad \text{and} \quad L = l \cdot \cos \alpha (= \sqrt{l^2 + h^2}),$$

$$\text{with } N = (t \cdot b) \cdot \bar{f}_{wc,s} \quad \text{and} \quad V = (t \cdot l) \cdot \bar{f}_{wv}$$

$$\text{Thus: } b \approx L \cdot (\bar{f}_{wv} / \bar{f}_{wc,s}),$$

Therefore for mean values of strengths before or during cracking, it is:

$$\underline{b \approx 0.15 \cdot L} \quad (\text{S.15})$$

- Analysis of deformations

Simultaneously, and before or during cracking it is:

$$\tau = \gamma \cdot G \quad \text{and} \quad \sigma = \varepsilon \cdot E$$

$$\text{or } V/t \cdot l = (s/h) \cdot G \quad \text{and} \quad N/t \cdot b = (\Delta L/L) \cdot E,$$

$$\text{with } V = N \cdot \cos \alpha \quad \text{and} \quad \Delta L = s \cdot \cos \alpha$$

$$\text{Thus: } \underline{G \cdot l \approx E \cdot b \cdot \sin \alpha \cdot \cos^2 \alpha}, \quad (\text{S.16a})$$

$$\text{or, for } b \approx 0.15 \cdot L, \quad G \approx 0.15 \cdot E \cdot \sin \alpha \cdot \cos \alpha \approx 0.15 \cdot E \cdot (h \cdot l / L^2),$$

where α is the slope angle of the diagonal strut to the horizontal.

Respectively, and regarding the axial stiffness of the strut (with $A_p = t \cdot b$) and the

shear stiffness of the panel (with $A\phi=t \cdot l$) it is

$$\underline{G \cdot A_{\phi} \approx E \cdot A_p \cdot \sin \alpha \cdot \cos^2 \alpha}, \quad (\text{S.16b})$$

see also Chapter 5, § 5.9.2.

Therefore, for compatibility reasons, the relationship of G and E of the two “equivalent” models (diagrams) of the infill wall (see the relevant diagrams τ - γ or σ - ε) are given by the previous relations, and not e.g. the expression $G \approx 1/3 \cdot E$ (for $\nu \approx 0.5$).

Αντιστοίχως, οι ανηγμένες παραμορφώσεις γ και ε συνδέονται μέσω της σχέσεως
Correspondingly, the normalised deformation γ and ε are connected through the relationship:

$$\gamma \approx \varepsilon \cdot \cos \alpha \cdot \sin \alpha \approx \varepsilon \cdot L^2 : h \cdot l \approx \varepsilon \cdot \left(\frac{l}{h} + \frac{h}{l} \right) \quad (\text{S.16c})$$

as also presented in the relevant models/diagrams.

- ii) With respect to the σ - ε model of the diagonal strut, and when more accurate data are not available, the following diagram may be used for performance level B:

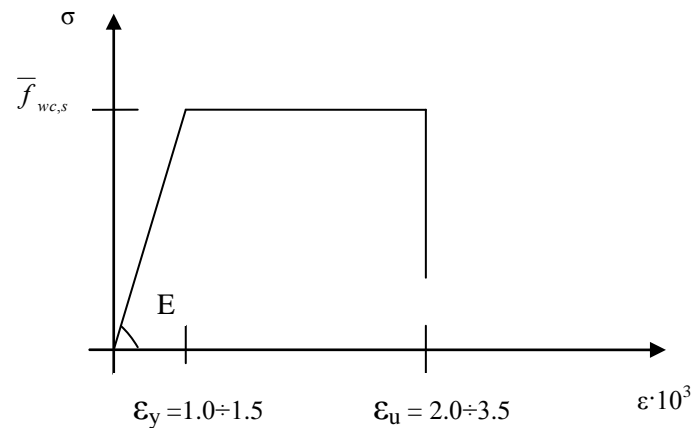

Stress-strain diagram of an equivalent diagonal strut for an unreinforced infill

wall

The choice of ε_y and ε_u values should be made in accordance with the prescribed value ranges, i.e. small ε_y correspond small ε_u etc.

For the estimation of the mean compressive strength, $\bar{f}_{wc,s}$, of the infill wall in the direction of the diagonal strut, as mentioned above, the mean compressive strength in the vertical direction shall be taken into account together with its reduction due to transverse (horizontal) tensile stresses.

In the absence of more accurate data, this strength may be estimated through the characteristic value of the compressive strength of the infill wall in the vertical direction, $f_{wc,k}$ according to EC6 (Table 3.3), as follows:

$$\bar{f}_{wc,s} = \lambda_m \lambda_s \lambda_c k f_{bc}^{0.7} f_{mc}^{0.3} \approx 1,25 k f_{bc}^{0.7} f_{mc}^{0.3},$$

(S.18)

where :

$\lambda_m = 1.5$ conversion coefficient of the characteristic strength into mean strength,

$\lambda_s = 0.7$ reduction coefficient to account for the unfavourable effect of inclined loading,

$\lambda_c = 1.2$ augmentative coefficient to account for the favourable effect of confinement provided to the infill wall by the surrounding reinforced concrete elements,

f_{bc} and f_{mc} the compressive strength of bricks and mortar, respectively,

k : empirical coefficient, which takes into account the group to which bricks are classified and the type of mortar (Table 3.3. of EC6). For common mortars,

the coefficient takes values between 0.35 and 0.55.

When the vertical joints of the wall are not filled with mortar, the value of the compressive strength of the diagonal strut is multiplied by an additional reduction factor (beyond λ_s). In the absence of more accurate data, this reduction coefficient is estimated based on the percentage of filled vertical joints and can take values between 0.60 and 0.90.

When the thickness of horizontal joints of the wall is greater than 15mm, the value of the compressive strength of the wall is multiplied by an additional reduction factor equal to 0.85.

In the absence of other more accurate data, the following may be applied:

For beams as well as for columns of the surrounding frame, the contact length of these elements with the infill wall shall be derived from the width of the diagonal strut which has been taken into account for the calculation of the internal forces, given the performance level. A triangular distribution of the respective concentrated vertical or horizontal shear force along the contact length may be assumed (with the maximum stress value being at the “corner” of the frame).

Reinforced infill walls may result after strengthening existing infill walls through unilateral or ambilateral reinforced coating or jacketing, or by the addition of new wall panels, usually with interspersed reinforcement (vertically and horizontally).

- h) The horizontal and vertical concentrated shear force resulting from the effect and interaction of the infill wall and the surrounding frame, shall be examined during the verification of the columns and the beams of the frame, respectively, taking also into account the favourable potential direct transfer of end-shear (close to a beam or column support) through an inclined strut (see also EC2, § 6.2.3 (8), reduction coefficient β for V_{Ed} for concentrated loads near direct supports).

7.4.2 Reinforced infill walls

The calculation of the bearing capacity of reinforced infill walls is performed according to Chapter 8. See also related § 7.4.1 b and c (mainly), as well as Chapter 9 for verification of infill walls.

APPENDIX 7A

ANALYTICAL CALCULATION OF YIELD CURVATURE OF REINFORCED CONCRETE SECTION WITH RECTANGULAR COMPRESSION ZONE

This Appendix applies to rectangular cross sections. It also applies to L, T, Π etc. sections when the compression zone has a constant width b . This requirement is checked through the height of the compression zone at yielding, $\xi_y d$, with ξ_y calculated from Eq. (A.3).

If section yielding is due to yielding of the tensile reinforcement, then:

$$(1/r)_y = \frac{f_y}{E_s(1 - \xi_y)d} \quad (\text{A.1})$$

If section yielding is due to the non-linearity of the deformations of the concrete of the compression zone (for strain of the extreme compression fibre beyond $\varepsilon_c \approx 1.8f_c/E_c$), then:

$$(1/r)_y = \frac{\varepsilon_c}{\xi_y d} \approx \frac{1.8f_c}{E_c \xi_y d} \quad (\text{A.2})$$

The smallest value of $(1/r)_y$ from Eq. (A.1) and (A.2) is considered.

The height of the compression zone at yielding, ξ_y , normalised to the effective depth, d , is:

$$\xi_y = (\alpha^2 A^2 + 2\alpha B)^{1/2} - \alpha A, \quad (\text{A.3})$$

Where $\alpha = E_s/E_c$ and A, B are calculated according to the following Eq. (A.4) or (A.5), depending whether yielding is controlled by tension reinforcement or concrete under compression, respectively:

I. Yielding due to steel:

$$A = \rho + \rho' + \rho_v + \frac{N}{bdf_y},$$

$$B = \rho + \rho' \delta' + 0.5\rho_v(1 + \delta') + \frac{N}{bdf_y} \quad (A.4)$$

II. Διαρροή λόγω παραμορφώσεων σκυροδέματος:
II. Yielding due to concrete deformations:

$$A = \rho + \rho' + \rho_v - \frac{N}{\varepsilon_c E_s b d} \approx \rho + \rho' + \rho_v - \frac{N}{1.8\alpha bdf_c}$$

$$B = \rho + \rho' \delta' + 0.5\rho_v(1 + \delta'). \quad (A.5)$$

In Eq. (A.4) and (A.5), ρ , ρ' and ρ_v are the ratios of the tension, compression and intermediate reinforcement (normalised to bd), $\delta' = d'/d$, where d' is the distance from the centre of the compression reinforcement up to the extreme compression fibre, b is the width of the compression zone and N the axial load (positive for compression).

Given the curvature at yielding, the corresponding moment M_y is given by:

$$\frac{M_y}{bd^3} = (1/r)_y \left\{ E_c \frac{\xi_y^2}{2} \left(0.5(1 + \delta') - \frac{\xi_y}{3} \right) + \left[(1 - \xi_y)\rho + (\xi_y - \delta')\rho' + \frac{\rho_v}{6}(1 - \delta') \right] \cdot (1 - \delta') \frac{E_s}{2} \right\}. \quad (A.6)$$

Αντί των Εξ. (Α.1) έως και (Α.5) μπορούν να χρησιμοποιηθούν προσεγγιστικά οι ημι-εμπειρικές σχέσεις:
Instead of Eq. (A.1) to (A.5), the following semi-empirical relations may be used approximately:

For columns or beams:

$$(1/r)_y = 1.77f_y/E_s h$$

(A.7α)

or

$$(1/r)_y = 1.55f_y/E_s d$$

(A.7β)

For shear walls:

$$(1/r)_y = 1.44f_y/E_s h$$

(A.8α)

or

$$(1/r)_y = 1.36f_y/E_s d$$

(A.8β)

APPENDIX 7B

TABLES FOR THE CALCULATION OF CHORD ROTATION AND PLASTIC CHORD ROTATION OF REINFORCED CONCRETE MEMBERS WITH RECTANGULAR COMPRESSION ZONE AT FLEXURAL FAILURE

The tables relate cyclic loading and reinforced concrete members with rectangular compression zone of width b , and seismic detailing (according to the perceptions and provisions that are applied in Greece since 1985) but in any case with ribbed steel reinforcements.

For members without seismic detailing (that is, constructed under practices applicable in Greece before 1985) it is assumed that $\alpha\omega_w=0$ if stirrups are not closed inwards, while in addition the values of the Tables for the mean value of chord rotation at failure, θ_u , or for the mean value of the plastic chord rotation at failure, θ_u^{pl} , need to be multiplied by 0.833 in case of ribbed reinforcement. In case of plain (smooth) steel bars, the values of the Tables for the mean value of chord rotation at failure, θ_u , need to be multiplied by 0.79, and for the mean value of the plastic chord rotation at failure, θ_u^{pl} , by 0.75.

The relevant Tables contain mean values of chord rotations.

For verification of quasi-ductile members in terms of deformations according to Chapter 9, the relevant mean values are divided by the appropriate γ_{Rd} factor with values according to Chapter 9.

Finally, for older, more brittle steels (see paragraph 4.2), the relevant mean values of the Tables need to be multiplied by a final coefficient equal to 0.6 for the calculation of the chord rotation at failure, θ_u , or 0.5 for the calculation of the plastic chord rotation at failure, θ_u^{pl} .

1) *Chord rotation at failure*

Mean value of chord rotation at failure, θ_u (%) – Beams & Columns								
$f_c \omega' / (\omega + \omega_v)$ (MPa)	5	10	15	20	25	30	35	40
$M/Vh = \alpha_s$								
1	2.3	2.7	2.9	3.1	3.3	3.4	3.5	3.6
2	2.9	3.4	3.7	4.0	4.2	4.3	4.5	4.6
3	3.3	3.9	4.3	4.6	4.8	5.0	5.2	5.3
4	3.7	4.3	4.7	5.0	5.3	5.5	5.7	5.9
5	4.0	4.7	5.1	5.5	5.7	6.0	6.2	6.4
6	4.3	5.0	5.4	5.8	6.1	6.4	6.6	6.8

Mean value of chord rotation at failure, θ_u (%) – Shear walls								
$f_c \omega' / (\omega + \omega_v)$ (MPa)	5	10	15	20	25	30	35	40
$M/Vh = \alpha$								
1	1.3	1.5	1.7	1.8	1.9	2.0	2.0	2.1
2	1.7	2.0	2.2	2.3	2.4	2.5	2.6	2.7
3	1.9	2.3	2.5	2.6	2.8	2.9	3.0	3.1
4	2.1	2.5	2.7	2.9	3.1	3.2	3.3	3.4
5	2.3	2.7	3.0	3.2	3.3	3.5	3.6	3.7
6	2.5	2.9	3.2	3.4	3.5	3.7	3.8	3.9

Correction factor of θ_u value due to normalised axial load $v = N/bhf_c$							
$v =$	0	0.1	0.2	0.3	0.4	0.5	0.6
$\lambda_v =$	1.00	0.89	0.79	0.70	0.62	0.55	0.49

Correction factor of θ_u value due to effective volumetric mechanical ratio of confinement reinforcement						
$\alpha\omega_w =$	0	0.05	0.1	0.15	0.2	0.25
$\lambda_{\alpha\omega_w} =$	1.00	1.08	1.17	1.27	1.33	1.38

Correction factor of θ_u value due to diagonal reinforcement ρ_d % in each direction				
ρ_d (%) =	0	0.5	1	1.5
$\lambda_{\rho_d} =$	1.00	1.12	1.25	1.40

2) Plastic chord rotation at failure

Mean value of plastic chord rotation at failure, θ_u^{pl} (%) – Beams & Columns – $f_c=25\text{MPa}$									
$\omega' / (\omega + \omega_v)$	0.2	0.4	0.6	0.8	1.0	1.2	1.4	1.6	1.8
$M/Vh = L_s/h$									
1	1.7	2.1	2.4	2.6	2.7	2.9	3.0	3.2	3.3
2	2.2	2.7	3.0	3.3	3.5	3.7	3.9	4.0	4.2
3	2.5	3.1	3.5	3.8	4.0	4.3	4.5	4.6	4.8
4	2.8	3.4	3.8	4.2	4.5	4.7	4.9	5.1	5.3
5	3.0	3.7	4.1	4.5	4.8	5.1	5.3	5.6	5.8
6	3.2	3.9	4.4	4.8	5.1	5.4	5.7	5.9	6.1

Mean value of plastic chord rotation at failure, θ_u^{pl} (%) – Shear walls – $f_c=25\text{MPa}$									
$\omega' / (\omega + \omega_v)$	0.2	0.4	0.6	0.8	1.0	1.2	1.4	1.6	1.8
$M/Vh = L_s/h$									
1	0.9	1.2	1.3	1.4	1.5	1.6	1.7	1.8	1.8
2	1.2	1.5	1.7	1.8	2.0	2.1	2.2	2.3	2.3

3	1.4	1.7	1.9	2.1	2.3	2.4	2.5	2.6	2.7
4	1.5	1.9	2.1	2.3	2.5	2.6	2.8	2.9	3.0
5	1.7	2.1	2.3	2.5	2.7	2.9	3.0	3.1	3.2
6	1.8	2.2	2.5	2.7	2.9	3.0	3.2	3.3	3.4

Correction factor of θ_u^{pl} value due to concrete compressive strength f_c							
$f_c =$	10	15	20	25	30	35	40
$\lambda_{fc} =$	0.83	0.90	0.96	1.00	1.04	1.07	1.10

Correction factor of θ_u^{pl} value due to normalised axial load $v = N/bhf_c$							
$v =$	0	0.1	0.2	0.3	0.4	0.5	0.6
$\lambda_v =$	1.00	0.87	0.76	0.66	0.57	0.50	0.44

Διορθωτικός συντελεστής τιμής θ_u^{pl} λόγω ενεργού ογκομετρικού μηχανικού ποσοστού οπλισμού περίσφιγξης Correction factor of θ_u^{pl} value due to effective volumetric mechanical ratio of confinement reinforcement						
$\alpha_{\omega} =$	0	0.05	0.1	0.15	0.2	0.25
$\lambda_{\alpha\omega} =$	1.00	1.08	1.17	1.27	1.33	1.38

Διορθωτικός συντελεστής τιμής θ_u^{pl} λόγω διαδιαγώνιου οπλισμού ρ_d % ανά διεύθυνση Correction factor of θ_u^{pl} value due to diagonal reinforcement ρ_d % in each direction				
ρ_d (%) =	0	0.5	1	1.5
$\lambda_{\rho d} =$	1.00	1.13	1.28	1.44

APPENDIX 7C

REDUCTION OF SHEAR STRENGTH OF REINFORCEMENT CONCRETE MEMBERS DUE TO CYCLIC POST-ELASTIC DEFORMATIONS.

The shear strength, V_R , of a reinforced concrete structural element (column, beam or shear wall) subjected to cyclic deformations decreases with the magnitude for the plastic part of the chord rotation at the cross section with the maximum bending moment. If this measure is normalised to the chord rotation at yielding at the same location, it is $\mu_0^{pl} = \mu_0 - 1$. The plastic part of the chord rotation ductility factor: $\mu_0^{pl} = \mu_0 - 1$ is equal to the ratio of the plastic part of the maximum value of the chord rotation (total chord rotation minus chord rotation at yield) to the chord rotation at yield, calculated according to Eq. (S.1) and (S.3).

The shear strength of a structural element as controlled by stirrup yielding may be considered to decrease with the value of μ_0^{pl} as follows (units are MN and m):

$$V_R = \frac{h-x}{2L_s} \min(N; 0,55A_c f_c) + \left(1 - 0,05 \min\left(5, \mu_{\theta}^{pl}\right)\right) \left[0,16 \max(0,5; 100\rho_{tot}) (1 - 0,16 \min(5; \alpha_s)) \sqrt{f_c} A_c + V_w\right], \quad (C.1)$$

where:

h: height of cross section (equal to diameter D for circular sections)

x: ύψος της θλιβόμενης ζώνης, height of the compression zone

N: axial load (positive for compression, zero for tension)

α_s : shear ratio

A_c : area of concrete section, equal to $b_w d$ for cross sections with a rectangular web with width b_w and effective depth d , or with $\pi D_c^2/4$ (where D_c = diameter of section core within the stirrups) for circular sections.

f_c : θλιπτική αντοχή σκυροδέματος (MPa). concrete compressive strength (MPa).

ρ_{tot} : total ratio of longitudinal reinforcement (tension, compression and intermediate).

V_w : contribution of transverse reinforcement to shear strength, equal to:

- For cross sections with a rectangular web with width b_w :

$$V_w = \rho_w b_w z f_{yw}, \quad (C.2)$$

where:

ρ_w : the ratio of transverse reinforcement,

z : the length of the internal lever arm (equal to $d-d'$ for columns, beams and T- or H-section shear walls, or to $0.8h$ for rectangular shear walls) and

f_{yw} : the yield stress of transverse reinforcement.

- For circular cross sections:

$$V_w = \frac{\pi}{2} \frac{A_{sw}}{s} f_{yw} (D - 2c), \quad (C.3)$$

where:

A_{sw} : the cross-sectional area of a circular stirrup,

s : the centreline spacing of stirrups, and

c : the concrete cover.

More specifically, the shear strength of a shear wall, V_R , may not be taken greater than the value corresponding to failure by web crushing, $V_{R,max}$, which under cyclic deformations, elastic or post-elastic, may be calculated from the following expression (units MN and meters):

$$V_{R,max} = 0,85 \left(1 - 0,06 \min(5; \mu_{\theta}^{pl})\right) \left(1 + 1,8 \min(0,15; \frac{N}{A_c f_c})\right) \left(1 + 0,25 \max(1,75; 100 \rho_{tot})\right) (1 - 0,2 \min(2; \alpha_s)) \sqrt{f_c} b_w z \quad (C.4)$$

The value of $V_{R,max}$ prior to flexural yielding is obtained from Eq. (C.4) for $\mu_{\theta}^{pl}=0$.

Moreover, the shear strength, V_R , of columns with shear ratio $\alpha_s \leq 2.0$ may not be taken greater than the value corresponding to failure by web crushing along the diagonal of the column after flexural yielding, $V_{R,max}$, which under cyclic post-elastic deformations decreases with the magnitude of the plastic part of the chord rotation ductility factor, $\mu_{\theta}^{pl} = \mu_{\theta} - 1$, as follows (units MN and m):

$$V_{R,max} = \frac{4}{7} \left(1 - 0,02 \min(5; \mu_{\theta}^{pl})\right) \left(1 + 1,35 \frac{N}{A_c f_c}\right) \left(1 + 0,45(100 \rho_{tot})\right) \sqrt{\min(40; f_c)} b_w z \sin 2\delta \quad (Γ.5)$$

where δ is the angle between the diagonal and the axis of the column ($\tan \delta = h/2L_s = 0.5/\alpha_s$).

APPENDIX 7D

INDICATIVE VALUES OF REDUCTION FACTORS r FOR THE MECHANICAL CHARACTERISTICS OF DAMAGED MEMBERS, WITHOUT REPAIR OR STRENGTHENING

- The skeleton behaviour curve (F' - d') of damaged (mainly due to earthquake) structural elements, connections, joints etc., is generally degraded compared to its counterpart prior to damage (F - d), according to the figure below (see also § 7.3.a):

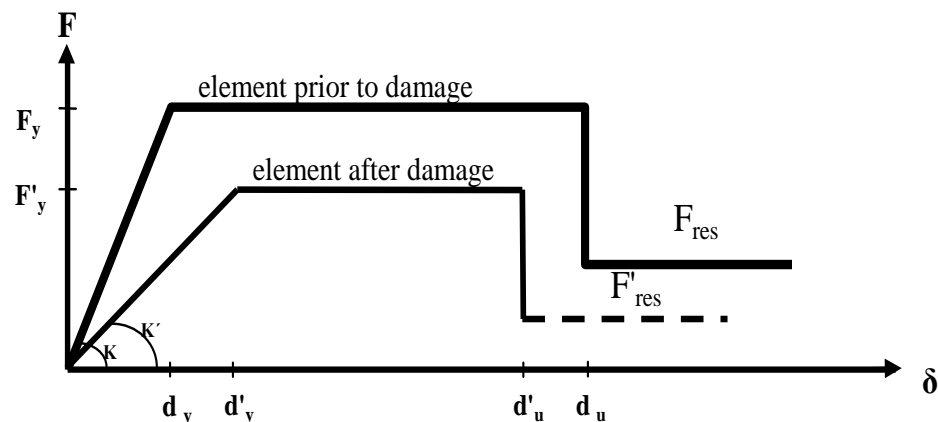

Specifically for damaged elements, due to too many uncertainties, a residual strength branch is not foreseen after quasi-failure (i.e. $F'_{res} \approx 0$).

- Depending on the type and extent of damage, for structural elements, joints etc., reduction factors r may be defined for the mechanical characteristics (“damage indices”), as follows:

$$r_k(=K'/K) \leq r_R(=F'_y/F_y) \leq r_{du}(=d'_u/d_u)$$

Thus, values of the r factor equal to 1 (or slightly lower) correspond to the initial state of the element prior to damage (or for damage with small impact), while values of r closing on 0 correspond to full failure and in effect “loss” of the damaged element (exhaustion also of its ductility).

- As substantial damages, i.e. for the purposes of the present Standard, are defined those that have led to a reduction of the bearing capacity (in terms of forces) larger than 25%, i.e. $r_R \leq 0.75$ (see also § 4.6.2).

Certainly, according to the provisions of Chapter 8, appropriate repair techniques (and materials) can be (or must be) applied in order to fully restore (under certain conditions) the mechanical characteristics of the damaged elements, i.e. $r \rightarrow 1$, regardless of possible strengthening (perhaps even before).

BODY

4. For assessment purposes only, and to facilitate a possible parametric investigation of the consequences of the damage (and the extensive redistribution of the consequences of the actions that they entail), the values of the \mathbf{r} factors may be modified through appropriate (model) coefficients γ_{Rd} , i.e. through the relationship r/γ_{Rd} , with γ_{Rd} values greater or less than 1 (to account for unfavourable or favourable effect) according to the justified judgement of the Engineer, see also § 7.3.b.
5. Visual sketches and indicative values of reduction factors \mathbf{r} (damage “indices”) are given in the following pages for damaged structural elements, without repair (or strengthening), as well as for infill walls, essentially after earthquake.
6. Because, for the purposes of the present Standard, the skeleton behaviour curves (F- d and F’- d’) involve mainly “force” F in terms of bending moment (M) or shear force (V), it is possible that reduction factors \mathbf{r} may be required also in terms of axial force only (i.e. r_N , generally greater than r_R (R=M or V), depending on the type and extent of damage, according to the justified judgement of the Engineer.
7. Also, because the earthquake “reveals”, as has been repeatedly observed, pre-existing wear (attack on materials) and impairment of the mechanical characteristics of the members, an additional reduction of the \mathbf{r} factors may be required depending on the age, use and environment of the building, as well as the observed wear of the element, according to the justified judgement of the Engineer.
8. Depending on the structural element, any damage due to (mainly) earthquake may be classified into characteristic typical degrees of damage, depending on which the reduction factors \mathbf{r} may be estimated.
9. Thus, as already mentioned, depending on the structural element and the type/degree of its damage, the appropriate \mathbf{r} values are estimated (see previous § 6 and 7), with smaller values for more serious (and more “dangerous”) damage.
10. For COLUMNS, but also for beams, the damage may be classified as per figure S1, while the corresponding \mathbf{r} factors are given in Table P1.

Especially for damage at column bases, in the area of starter bars / lap splices of longitudinal reinforcement bars, Table P2 gives the values of reduction factors \mathbf{r} (r_M) compatible with the damage, while r_V values may be taken as 85% of r_M .

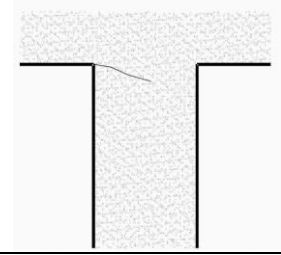
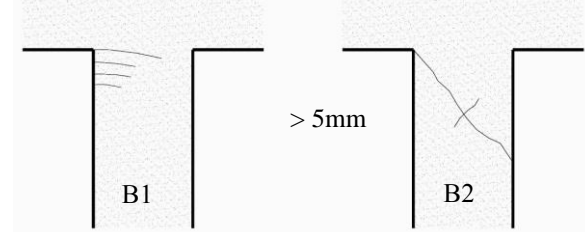
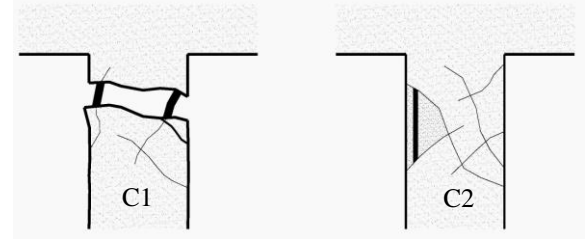
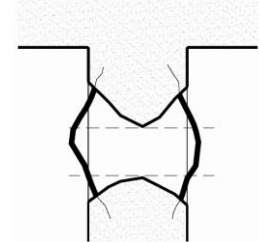
Limited importance	Light damage	A	 <p style="text-align: center;">$< 2\text{mm}$</p>	$d=0$
		B	 <p style="text-align: center;">$> 5\text{mm}$ $< 3\text{mm}$</p> <p style="text-align: center;">B1 B2</p>	$d \ll$
Affecting the overall safety	Serious	C	 <p style="text-align: center;">C1 C2</p>	$d < 1\%$
	Heavy	D or D/E	 <p style="text-align: center; color: blue;">Buckling or fracture of bars, opening or fracture of stirrups</p>	$d > 2\%$

S1: Typical degrees of damage of columns (and beams)
(d: storey drift or drift of member ends)

P1: Reduction factors r for damaged columns (and beams)

Typ. Degree	Damage description	r_K	r_R	r_{du}	F(=R)
A	Light flexural damage (no damage from shear). Single, isolated cracks, roughly perpendicular to member axis, <2mm, absence of diagonal cracks.	0,95	1,00	1,00	M ή V
A/B	Light damage, flexural or from shear 1. Cracks (multiple rather than single) roughly perpendicular to member axis (<2mm), diagonal cracks (<1mm). Absence of visible permanent displacements or buckling. Absence of spalling. 2. Moderate cracks roughly perpendicular to member axis (3÷5mm), diagonal cracks (1÷2mm). Absence of visible permanent displacements or buckling. Light spalling.	0,90	1,00	1,00	M
		0,80	0,90	1,00	V
		0,70	0,90	0,95	M
		0,50	0,80	0,90	V
B	Serious flexural/moderate shear damage. Cracks roughly perpendicular to member axis (>5mm), diagonal cracks (<3mm). Absence of displacements or buckling. Spalling.	0,55	0,80	0,90	M
		0,40	0,60	0,80	V
C/D	Serious to heavy damage 1. Flexural Buckling of bars and spalling, core disintegration or intense side-to-side cracking, with slip, or permanent drift of member ends $1\div 2\% l$ 2. Shear Intense diagonal cracks (>3mm), multiple rather than single, diagonal or crosswise, small but noticeable permanent drift of member ends.	0,30	0,50	0,70	M
		0,20	0,30	0,60	V
D (or D/E)	Total failure, loss of member Buckling or/and fracture of bars, or opening (or fracture) of stirrups, or cracks >10mm, or permanent drift of member ends >2% l (including potential slip)	0	0	0	M ή V

P2: Reduction factors r for damaged lap splices at bases of columns (or other lap areas)

Typ. Degree	Damage description	r_K	r_R	r_{du}	F(=R)
A/B	Moderated damage in lap splice areas. Cracking along bars. Short cracks roughly perpendicular to member axis. Light spalling.	0,70	0,70	0,90	$M^{(*)}$
C/D	Heavy damage in regions of lap splices. Intense and deep spalling, bare segments of reinforcement bars (exposure)	0,50	0,50	0,70	$M^{(*)}$

(*) It may be taken $r_V \approx 0.85 r_M$.

11. For SHEAR WALLS, which are predominantly primary (under earthquake) structural elements, in the absence of other data, in principle the classification of damage according to figure S1 as well as Table P1 may be used for the values of the reduction factor r .
- Simple slip, with cracks <3mm and displacement <10mm
 $r_M \approx r_V$, $r_K \approx 0.40$ / $r_R \approx 0.60$ / $r_{du} \approx 0.70$
 - Intense slip, with cracks >5mm and displacement >15mm
 $r_V \approx 0.90 r_M$, with r_M as follows: $r_K \approx 0.20$ / $r_R \approx 0.30$ / $r_{du} \approx 0.50$
12. Finally, for common unreinforced (existing) INFILL WALLS, with perforated bricks and poor (generally) grouts, the recommendations (in case of damage) of figure S2 and Table P3 may be used, in the absence of more accurate and detailed data. Reduction factors r for infill walls relate to their shear resistance (or to the resistance of the equivalent diagonal strut in compression), according to Chapters 5, 7 and 8. It is stressed that the definition of typical degrees of damage (in correspondence with those for reinforced concrete structural elements) is difficult and (largely) unreliable for existing infill walls. Thus, for the purposes of the present Standard, a simpler classification to degrees of damage is used (see figure S2).

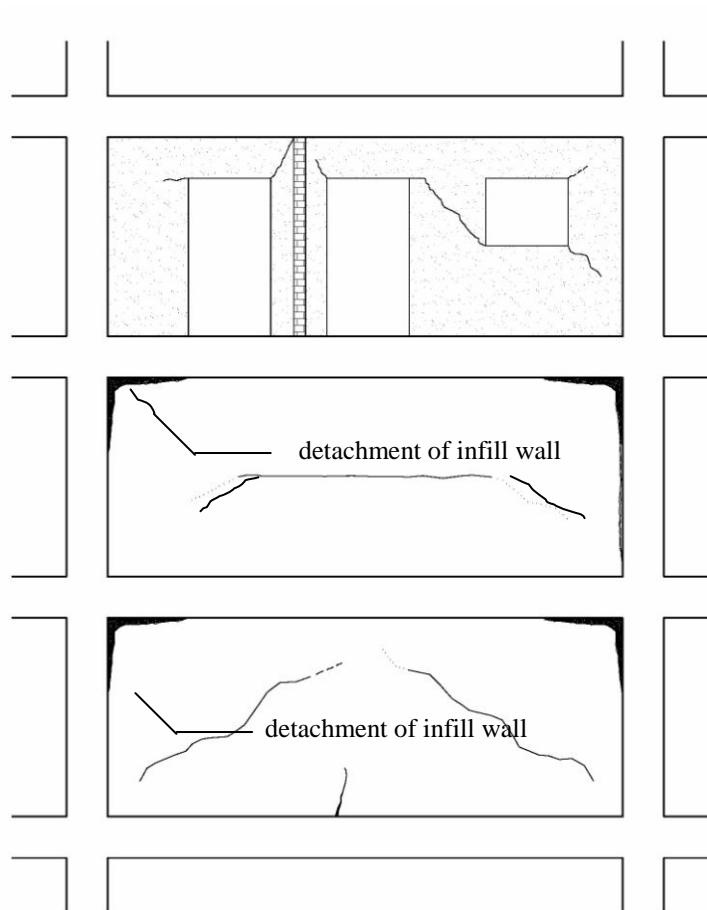

S2.1: Characteristic light (to moderate) infill wall damage, with cracks $< 2\div 3\text{mm}$
(some of the damage may be due to permanent deformation of the structure, or the beam/slab system)

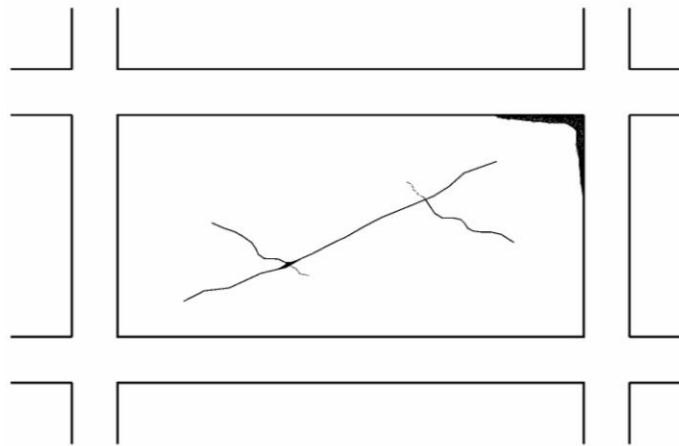

S2.2: Serious infill wall damage, cracks > 5mm

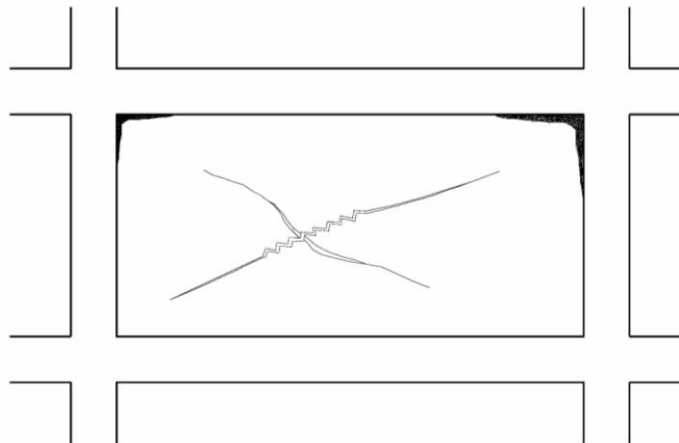

S2.2: Heavy infill wall damage, cracks > 10mm

P3: Reduction factors r (r_v) for damaged common unreinforced infill walls

Degree of Damage	Damage description	r_K	r_R
Light	Light (to moderate) cracks, < 2÷3 mm, around openings, or detachment of infills from the main structure.	0.90	0.90
	Multiple light cracks, especially in walls with openings	0.70	0.70
Serious	Intense cracking, diagonal or crosswise, with crack width > 5mm, detachment from the main structure, cracking of the tie beams, absence of significant out-of-plane deformations (<5mm).	0.50	0.50
Heavy	Intense cracking, generally crosswise diagonal, with crack width > 10mm, detachment from main structure, damage of tie beams and small out-of-plane deformations (smaller than 15mm)	0.20	0.20

Note

Values of r_{du} , for the deformation at failure of damaged infill walls are not given. In those cases, it is safer (and more reliable) to assume that “failure” coincides with “yielding” ($F_u \approx F_y$ and $d_u \approx d_y$, see skeleton behaviour curves).

CHAPTER 8**DESIGN OF INTERVENTIONS****8.1 GENERAL REQUIREMENTS****8.1.1 Introduction**

In any case, the works are performed in accordance to the relevant technical specifications. Otherwise, the “Temporary National Technical Specifications (PETEP): Restoration Works of Structural Damage induced by the Earthquake and other harmful factors

- a) Every intervention on an existing structure, with or without damage, aims to serve the target of redesign (see Chapter 2), and is implemented with the addition of new materials or components to existing structural members.

(Technical Chamber of Greece/IOK, 2008)” apply. Either way, the intervention shall include the restoration (repair) of any pre-existing damage or deterioration.

Recommended values of the “coefficient of monolithic connection” k are given in the individual provisions of this Standard; k being defined as the ratio of the critical measure of behavior of the composite section, over the relevant critical measure of a corresponding monolithic section (without any associated deformation at the interface) .

The uncertainties in determining the amplitude of the forces S_{id} that are acting on the interface are taken into account, depending on the means adopted for modeling the contact at the interface. For instance, appropriate uncertainty factors are considered regarding the stiffness of the joints, when such stiffness is introduced in the finite element model.

This force can be compressive, tensile or shear.

Due to the relative slip along the interface of the composite section that is subjected to bending, the actual distribution of deformations (see Fig. 8.1) leads to lower

b) Through this addition, it is deemed that a quasi-monolithic bond between old and new materials is restored.

Nevertheless, due to relative displacements (even small ones) at the interfaces of old/new materials, the resistance in critical regions or the deformation of structural members may not be fully monolithic.

c) The required each time bond of old to new materials shall be verified at the interface so that the following formula applies:

$$R_{id} \geq S_{id} \quad (8.1)$$

where:

R_{id} = The resistance of that bond at the relevant interface.

This resistance corresponds to a measure of maximum tolerable relative slip along the interface examined.

S_{id} = Corresponding force acting on the interface examined, as calculated from the design action effects acting in the particular region.

d) The mobilized resistance of the individual sections of the entire set of member interfaces which are created after the intervention (under the condition that § 8.1.1c applies), is

activation of internal forces within the attached component and thus, to a lower level of resistance of the composite member as a whole.

When there are no reliable methods available for predicting this relative slip (see § 8.1.2.3), it is permitted to use the approximate method of monolithic behavior, provided that the action effect will be taken as S_{id} / k , where k is the corresponding monolithic factor (§ 8.1.1b).

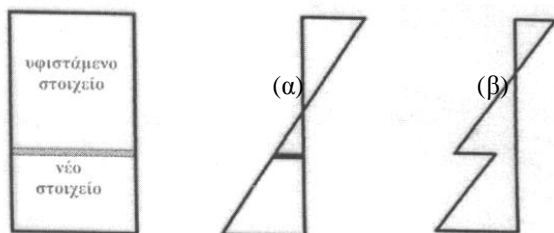

Fig. C8.1: Distribution of deformations within a composite section that is subjected to bending:
(a) monolithic behaviour,
(β) slip along the interface

Due to the usual brittle behavior of the interfaces, it is required to remain within the elastic range until the strengthened member fails.

verified on the basis of the requirements of the relevant Standard for each material. This verification is performed by taking into account the displacements along the interface.

- e) The increased resistance-related uncertainties during the design of the structural members that follows the intervention are taken into account through individual safety factors γ_{Rd} , where appropriate.
- f) Failure of the strengthened member must precede failure at the interfacial of the old-to-new materials. To this end, the verification of strength shall be performed for action effects that are multiplied by a factor $\gamma_{sd} = 1,35$.

See § 6.1

The slight local reduction in other properties (i.e., axial stiffness) is neglected.

(i) In these cases, the tensile strength of the interface is dictated by the tensile strength of the weakest material across the interface.
(ii) In normal cases it is not recommended to take into account the tensile detachment strength of concrete, except in the case that a suitable adhesive (e.g. epoxy resin) has been used and the work has been performed in accordance to the relevant technical specifications. Otherwise, it is recommended to apply the “Temporary National Technical Specifications (PETEP): Restoration Works of Structural Damage induced by the Earthquake and other harmful factors (Technical Chamber of Greece/IOK, 2008)”.

8.1.2 Interface resistance

The resistance of an interface can be either resistance to compression or resistance to tension or resistance to shear.

8.1.2.1 *Interface resistance to compression*

The interface resistance to compression is calculated by taking into account the compressive strength of the weakest material across the interface, provided that all gaps or cracks have been filled by using an appropriate technique and material.

8.1.2.2 *Interface resistance to tension*

The resistance of the interface to tension is calculated on the basis of the following criteria:

- a) Under some reliable and fully controllable conditions of application and specific maintenance, it is permitted to take into account the tensile detachment strength of the concrete with respect to the material added.

- b) When conditions of the preceding paragraph are not met, the tensile resistance at the interface is ensured by additional, appropriately anchored components, whose design follows the provisions related to the finite element models in Chapter 6.

8.1.2.3 *Interface shear resistance*

The conditions that have to be met in order to take into account a uniform mean value of slip along the entire interface length are described in Chapter 6.

The maximum tolerable relative slip at the interface depends on the target performance level and it can be taken equal to 0.2 or 0.8 or 1,5 mm, for levels A, B and C, respectively.

See § 6.1.1.3

See § 6.1.1.6 and 6.1.4

See § 6.1.1.4. and 6.1.1.5

Shear resistance at the interfaces is calculated with the following procedure:

- a) In order to derive the value of tolerable slip at the interfaces, the resistances that are mobilized by all available mechanisms at the interface are calculated, i.e.:
- i) Concrete-to-concrete bond, wherever it can be taken into consideration
 - ii) Concrete-to-resin bond
 - iii) Concrete-to-concrete friction at the interface under compression, taking into account:
 - the normal stresses that are induced by the external load actions
 - the normal stresses that are developed by

the mobilized pull-out resistance of any available anchored transverse reinforcement. These stresses are due to the swelling that occurs perpendicularly to the interface which is in turn induced by the acceptable value of relative slip.

- iv) Dowel resistance
- v) Resistance of links between existing and new reinforcement.

b) Interaction between the above mechanisms is taken into account.

c) Depending on the location and criticality of the regions of the structural member designed that are verified, potential attenuation of the above mechanisms due to cyclic loading is taken into consideration.

d) It is permitted to calculate the total resistance as the sum of the maximum resistance values of each individual mechanism available, reduced through appropriate participation factors that are significantly lower than unity.

e) The maximum normalized shear force at the interface shall not exceed the shear strength of the weakest concrete

$$\tau_d \leq 0,30 f_{cd} \quad (8.2)$$

See § 6.1.2

See § 6.1.1 and 6.2.2

See § 6.1.3

It is thus ensured that the concrete body does not fail due to extensive diagonal cracks.

In case that the structural member is capacity-designed, the internal forces acting at the interfaces shall be calculated accordingly.

8.1.3 Internal forces acting at the interface

The calculation of internal forces acting at interfaces which are located in critical regions of the members to be designed is performed on the basis of the structural analysis which is compatible to the design objective.

8.1.4 Maxima and minima

The maximum and minimum requirements for each type of intervention are in each case prescribed in the relevant paragraphs of this Standard, where required.

8.2 INTERVENTIONS IN CRITICAL REGIONS OF LINEAR STRUCTURAL MEMBERS

8.2.1 Interventions with a capacity objective against flexure with axial force

8.2.1.1 Local repair of a damaged member region

In R/C members that have suffered relatively minor damage ($r_R \geq 0,8$, see § 7D), it is possible to locally restore an “equivalent” section, with or without epoxy resin injections, in order to recover the pre-damage characteristics of the member. It is recommended to apply the “Temporary National Technical Specifications (PETEP): Restoration Works of Structural Damage

Structural members that have suffered relatively minor damage can be considered as monolithic after local restoration of the damaged region, provided that the relevant requirements of the applicable Technical Specifications have been met.

induced by the Earthquake and other harmful factors (Technical Chamber of Greece/IOK, 2008)”.

In R/C members with more severe damage ($r_R < 0,8$, see § 7D) the above techniques of local rehabilitation of the damaged area can be applied, so that the repaired member can be considered as monolithic with a corresponding coefficient $k_i = r_i / 0,8 \leq 1$, where r_i is the relevant damage coefficient prescribed in Annex 7D.

The required lap splice length in existing structures may be taken equal to the anchorage length prescribed in EC2 § 8.4.; however, the resistance of the materials is introduced with its mean value and without any other overlapping multiplier such as e.g. α_6 of § 8.7.3 of EC2.

For the welding of rebars, the relevant provisions of the Steel Technology Standard apply, together with any other relevant technical specification that is into force. It is also recommended to apply the “Temporary National Technical Specifications (PETEP): Restoration Works of Structural Damage induced by the Earthquake and other harmful factors (Technical Chamber of Greece/IOK, 2008)”.

When the force transfer between the rebars is made through welding, the potentially reduced ductility and/or strength in the particular member region shall be considered during design, depending on the location of the welding, the type of the welded steel, the welding process and the type of connection. To this end, it is necessary to conduct appropriate laboratory tests on samples welded with the same personnel under the same conditions. In case

8.2.1.2 *Restoration of insufficient lap splice length of the reinforcement*

When the available lap splice length (ℓ_s) of the rebars in the lapping regions is not sufficient, it is permitted to improve the conditions of force transfer between the rebars with the use of the following methods:

- a) Welding of the lapped rebars or extension of existing ones through welding of additional rebars, provided that the axial spacing of the rebars is sufficiently small. The complete transfer of forces from one rebar to the other is ensured under the condition that the requirements of relevant Technical Standards for welding have been met.

that no tests are performed, it shall be conservatively considered that the local ductility factor m is equal to unity within the entire welded region of the member. It is recalled that, as it is commonly assumed during design, the moment capacity in the lapping region of the rebars, is determined on the basis of the presence of a single rebar.

It is generally recommended to avoid welding of lap splices in primary vertical primary structural members.

With respect to the finite element modeling of this behavior see § 6.3.

As the external confinement reinforcement, either steel or fiber reinforced materials can be used in the form of jackets or collars or coat or external fasteners. It is a pre-requisite in construction to ensure full contact of the confinement material with the surface of the structural member. The construction of a reinforced concrete jacket is also an option. In this case, the jacket stirrups play the role of external confinement reinforcement.

In every case that this technique is used, the works shall be performed in accordance to the relevant technical specifications. Otherwise the “Temporary National Technical Specifications (PETEP): Restoration Works of Structural Damage induced by the Earthquake and other harmful factors (Technical Chamber of Greece/IOK, 2008)” apply.

The contribution of the stirrups of an existing structural member is ignored unless the stirrups are dense and well-anchored (with the prescribed by EC8 (§ 5.6.1 (2)) hooks or other suitable construction arrangement).

In accordance, it case taken that $\gamma_{Rd} = 1,5$

- b) Application of external confinement to the structural member.
 - i) The purpose of confinement is to prevent premature failure of the lap region due to splitting of the concrete surrounding the rebar (hence, failure of the force transfer mechanism between the rebars) and, finally, due to the slip along the critical crack that has been developed between the rebars, prior to their yield.
 - ii) The required confinement reinforcement can be calculated by the formula:

In case of a continuous external jacket or FRP fabric it applies that $w_j = s$ and $A_j / s = t_j$, where t_j is the thickness of the jacket.

In case of k successive layers of FRP fabric with thickness t_{j1} it applies that $t_j = \psi k t_{j1}$, where $\psi < 1$ is a reduction factor that accounts for the efficiency of multiple layers (see § 6.2.3.).

When more accurate data are not available, the design deformation ε_{jd} can be determined as $\varepsilon_{jd} = \sqrt{2} w / \bar{b}$ where $w = 0.6 \delta^{2/3}$ is the crack width that corresponds to the acceptable amplitude of the relative slip “ δ ” between the bars (see § 8.1.2.3) and $\bar{b} \cong \frac{b_1 + b_2}{2}$ where b_1 and b_2 are the two cross-sectional dimensions.

The design stress σ_{jd} that is mobilized shall not exceed the value $\sigma_{j,max} = f_{yd}$ when strengthening is performed with the use of steel components. In case that strengthening is performed using FRPs, it is recommended to limit the available FRP confinement strength by 25% ($\sigma_{j,max} = 0.75 E_j \varepsilon_{ju}$) in order to take into

$$A_j / s = \gamma_{Rd} \frac{(1 - \lambda_s)}{\beta} \frac{1}{\mu} \frac{f_{yk}}{\sigma_{jd}} \frac{A_b}{\ell_s} \quad (8.3)$$

where

$A_j = t_j w_j$ is the cross-sectional area of the confinement reinforcement in the form of collars, while t_j and w_j is the thickness and width of the collar section respectively.

s is the axial distance of the collars

$A_b = \pi d_s^2 / 4$ is the area of a lapped rebar.

consideration the additional local distress of the FRP that is attributed to the bending of the material and the outward deformation of the corner bar (i.e., incompatibility between the final length of the rebar and that of its surrounding concrete).

This contribution is taken into account when at least 50% of the stirrups prescribed by EC8 (§ 5.6.3) for the lap splice areas is indeed available at the particular lap splice area.

It is recommended to take $\lambda_s = 0$

The value of β is close to unity when $c/d_s \geq 2$, where: c is the smaller cover of a lapped rebar.

The concrete-to-concrete friction coefficient μ depends on the magnitude of the compressive stress (σ_N) on the interface of the crack on the tolerable relative slip along the crack. This friction coefficient is reduced by the cyclic slip imposed. As a result, the values of μ can practically range between 0.4 and 2.0 and it is difficult to be empirically estimated in an accurate manner. In the absence of other data, it could be considered roughly that $\mu = 1$.

Under the conditions of § 6.3 and for corner bars of rectangular structural members, it is possible to apply the following relationship that is derived from the eq. 6.14, setting $s_u = 2,0\text{mm}$:

$\sigma_{jd} = E_j \varepsilon_{jd}$ is the mobilized design axial stress of the confined members.

$$\beta = b_f / B \leq 1 \quad (8.4)$$

where

b_f is the width of the friction zone on the crack along the spliced rebars, and B is the width on which the total compressive force induced by the mobilized axial force of the confining material is distributed.

$$(F_j = \sigma_j A_j \frac{\ell_s}{s}).$$

μ is the friction coefficient that can be mobilized on the surface of potential slip at the location of the anticipated cracking.

$$(A_j/s)_{\text{απ.}} = 1.3 \left[k_1 \left(\frac{f_{sy}}{f_c} \frac{d_s}{\ell_s} \right) - 0.4 \frac{c}{d_s} - 0.30 \right]^2 \frac{f_c^2 d_s^2}{k_2 E_j f_{ctm}} \text{ (mm)} \quad (\text{C8.1})$$

where:

f_c, f_{sy} are the mean values of concrete and steel yield strength respectively

k_1, k_2 are coefficients that express the acceptable degree of damage prior to failure. These coefficients can be taken equal to:

$k_1=1,7$ for performance level A

$=1,5$ for performance level B or C

$k_2=0,3$

the ratio c/d_s shall not exceed 1.5.

For non-corner rebars (i.e., rebars located at distance greater than $3d_s$ from the corner of the structural member) the reinforcement used for strengthening may be estimated by assuming that it is acting as tie reinforcement of the critical crack slip. Decision regarding the appropriate for this case finite element model and the subsequent determination of the strengthening reinforcement is made after appropriate and thorough literature review that shall also include verification of the model reliability using available experimental results. Otherwise, in case of intermediate bars, the beneficial effect of confinement shall be neglected.

The value of the required lap splice length ℓ_{so} may be estimated according to the commentary of § 8.2.1.2.

- iii) The application of confinement can prevent failure of the bond of the lapped rebar, provided that the available lap length ℓ_s is greater than $0.30 \ell_{so}$ and $15 d_s$. Otherwise, it is considered that confinement cannot contribute and the local ductility factor (μ) of the structural member is equal to unity.

The minimum confinement length is derived as a function of the requirements for ductility and shear in the particular region. It is decided in order to ensure that: (a) the plastic hinge is not developed just above the confined member edge and (b) the unconfined portion of the member does not fail in shear.

- iv) The length of the member on which confinement is applied shall be at minimum equal to the height of the critical region and not less than $1,3 \ell_s$ or 0,60 m.
- v) In the case where continuous steel jacket is externally used, the thickness of the strengthening material shall be at least 1 mm, while in the case of fiber reinforced polymers the nominal thickness of the fibers must be at least 0,25 mm. If stirrups or collars are used with an area of A_j and a spacing s , the above values correspond to the ratio A_j/s and the distance s must not exceed 0,3d.

8.2.1.3 *Interventions with the objective to strengthen the tension zone against flexure with axial force*

The technique is mainly applied for slabs and beams, and rarely for columns or shear walls. The laminates or fabric are bonded to the flange under tension using suitable adhesive material (e.g. epoxy resin). In case that fiber reinforced polymers are used, it is permitted to use special anchors-dowels, provided that their effectiveness is well documented in the literature and justified through reliable experimental tests.

The alternative form of application of the particular technique using new rebars made of steel or fiber reinforced polymers, and being fixed with a suitable adhesive material (e.g. epoxy resin) within "channels" at the flange in tension, can be applied when relevant and reliable design methods are available. These

a) **Bonding of steel laminates or FRPs**

- i) Inadequacy of the tensile reinforcement in an existing R/C structural member can be addressed with bonding of steel sheets or fiber reinforced polymers (in the form of sheets or more rarely, of in-situ impregnated special fabric). This technique is not applied to areas that may be subjected to compressive strain due to cyclic bending or accidental action.

provisions do not cover this case.

The application of the additional reinforcement technique is recommended when the intended increase in flexural resistance of the member is not greater than the original one.

It should be taken into consideration that through this technique, apart from an increase in the flexural resistance of the member, significant increase in stiffness is also induced together with a restriction in deformations and cracking and the reduction of ductility.

To ensure the integrity of the strengthened structural member even after a potential failure of the strengthening due to an accidental action (e.g. fire), this member shall be as a minimum able to bear, initially, its permanent loads.

Through this recommendation it is aimed to ensure the desirable failure mode of the member, during which the strengthening material reaches the conventional ultimate deformation, while concrete at the compression zone exhibits deformation $\leq 0,0035$. In this way, the provision of excessive quantities of strengthening material, which would lead to premature brittle failure of the compression zone, is avoided.

The new reinforcement is calculated in order to be able to undertake, together with the existing reinforcement, the tensile forces that correspond to the overall bending stress at the region of strengthening. Approximately, the following formula can be used for the preliminary determination of the required area of strengthening reinforcement (A_j),:

$$A_j = \frac{\Delta M_{do}}{z \sigma_{jd}} \quad (C8.2)$$

- ii) The application of the technique is permitted provided that the existing structural member is able to resist, the internal forces induced by the permanent loads of the final design without any strengthening.
- iii) The amount of the bonded strengthening material is recommended to be decided so as to ensure that at the ultimate limit state, the deformation of the existing tensile reinforcement shall exceed its yield without failure in the compression zone of concrete.
- iv) Under the entire sets of conditions that are described below, the strengthened structural member is considered monolithic, while the estimation of its flexural resistance and of its other characteristics can be made by considering the strengthening material as new external reinforcement.

where:

ΔM_{do} is the additive bending moment that the strengthened section has to undertake (in addition to the M_{do} which can be undertaken by the initial section),

z , d_j is the lever arm of the internal forces (which can be taken equal to $0,9 d_j$) and

d_j is the depth of the section, measured from the level of the external reinforcement.

When the strengthening material is steel, then the ultimate condition is defined at its yield, whereas for the case of fiber reinforced polymers it is its fracture that is considered as failure. In the first case, it is assumed that $f_{jk} = f_{sy}$ and the value of the material safety factor $\gamma_m = \gamma_s$ is determined according to the provisions of § 4.5.3.2α. In the latter case, it is assumed that $\gamma_m = \gamma_{IOII} = 1,2$ in relevant compliance to the provisions of § 4.5.3.2β. Besides, when more than one FRP layers are used, the material strength is taken as $f'_{jk} = \psi f_{jk}$ where ψ is a reduction coefficient considering the number of the FRP layers (see § 6.2.3)

The modeling uncertainty coefficient γ_{Rd} can be taken equal to 1,2.

v) The design value of the effective stress σ_{jd} of the new reinforcement, is estimated on the basis of a critical value of stress $\sigma_{j,crit}$, and it shall not exceed the value σ_{jd} of stress that corresponds to the most critical of the following two modes of failure:

- Failure of the strengthening material itself, hence,

$$\sigma_{j,crit} = f_{jk} \text{ and} \quad (8.5)$$

$$\sigma_{jd} = \frac{1}{\gamma_m} \cdot f_{jk} \quad (8.6)$$

where

f_{jk} is the characteristic strength of the strengthening material and

γ_m is the partial safety factor for the strengthening material

- Premature debonding of the

For this particular mode of failure, the following relationships can be used (see also § 6.1.4):

$$\sigma_{j,crit.} \cong \beta \frac{\tau_b^{\alpha_{\pi\sigma\kappa.}}}{t_j} L_e \quad (C8.3)$$

where

$\beta = \beta_w \beta_L$, correction factor

$$\tau_b^{\alpha_{\pi\sigma\kappa.}} \cong f_{ctm}$$

L_e the effective anchorage length (i.e., the length above which the force that the strengthening material can transfer is not further increased), which is calculated by eq. (6.11), with the assumption that the width of the critical crack is 0,5 mm as follows:

$$L_e = \sqrt{\frac{E_j t_j}{2f_{ctm}}} \quad (\text{MPa,mm}) \quad (C8.4)$$

t_j , E_j is the thickness and the modulus of elasticity respectively.

In case that k successive layers of the strengthening material are used, of thickness t_{j1} it is assumed that $t_j = \psi k t_{j1}$, where ψ is the multiple layer reduction coefficient (see § 6.2.3).

$$\beta_w = \sqrt{\frac{2 - b_j/b_w}{1 + b_j/b_w}}, \text{ coefficient considering the width of the}$$

strengthening reinforcement

b_j the width of the strengthening material

b_w the width of the member flange in tension on which the strengthening material is bonded

strengthening material due to inadequate connection along the member length or anchorage of its edges, hence,

$$\sigma_{jd} = \sigma_{j,crit.} : \gamma_{Rd} \quad (8.7)$$

where,

γ_{Rd} is and appropriate safety factor quantifying the uncertainties in finite element modeling and

$\sigma_{j,crit.}$ is the material stress that leads to debonding. This stress can be calculated on the basis of § 6.1.4.

$\beta_L = \sin\left(\frac{\pi\lambda}{2}\right) \cong \lambda(2-\lambda)$ a coefficient of influence of the

available anchorage length, where $\lambda = \frac{L_{av}}{L_e} < 1,0$

and L_{av} the available anchorage length of the strengthening reinforcement

$\beta_L = 1,0$ when $\lambda \geq 1,0$.

This mode of failure commonly occurs in the form of splitting of the longitudinal reinforcement cover in the region of the strengthening reinforcement edge.

The verification procedure is justified with the use of reliable values from the literature. Approximately however, the following criterion can be applied:

$$V_{Sd}^{\alpha\pi\omega\lambda} \leq V_{Rd,c}^{\alpha\pi\omega\lambda} \text{ and } M_{Sd}^{\alpha\pi\omega\lambda} \leq 2/3 M_{Rd}^{\alpha\pi\omega\lambda}$$

where

$V_{Sd}^{\alpha\pi\omega\lambda}$ and $V_{Rd,c}^{\alpha\pi\omega\lambda}$ are the values of the design shear and the shear force that can be transferred by concrete (see §6.2.2 of EC2) at the location where the strengthening reinforcement terminates and

$M_{Sd}^{\alpha\pi\omega\lambda}$ is the design bending moment (that induces tension to the flange where the strengthening material is bonded) at the location where the strengthening reinforcement terminates

$M_{Rd}^{\alpha\pi\omega\lambda}$ is the corresponding moment resistance at the same

- vi) Specific verification is needed in case of premature shear failure of the initial member at the edge of the strengthening laminate (or fabric).

location.

In case that the above criterion is not met, additional external shear reinforcement is required to transfer the force:

$$V_{Sdj} = \frac{A_j \sigma_{jd}}{A_{so} f_{ydo} + A_j \sigma_{jd}} V_{Sd}^{απολ.}$$

(C8.5)

where

A_{so} , f_{ydo} is the area and the yield strength of the reinforcement of the initial member.

A_j is the area of the required external reinforcement for bending strengthening.

The number of layers, however, shall be more than 3 for the case of laminates and 5 for flexible fabrics; unless relevant documentation is available that permits the use of a larger number of layers. Moreover, the thickness of laminates shall not exceed 4 mm or 2% of the width of the laminate.

The distance of the strengthening material from the edges of the concrete section shall not exceed the thickness of the cover of the closest to the edge parallel rebar of the existing reinforcement.

In case where several parallel strips are used (typically in the case of slabs), their spacing shall not exceed 3 times the thickness of the member and $0,10 \ell_o$, where ℓ_o is the distance between the points of zero bending moment along the member.

Where strengthening is performed at the middle of a span, the strengthening material shall be extended and be anchored at the vicinity of the supports. In case of strengthening near the support of beams or slabs, the strengthening material is extended and

vii) It is recommended to:

- prefer the use of laminates (or fabrics) with small thickness.
- avoid lap splices of the strengthening material
- Follow appropriate rules regarding the geometric arrangement of the new reinforcement in order to achieve the best possible bond with the existing structural member.
- Anchorage of the strengthening reinforcement shall be made further to the point of zero bending moment (i.e., within the compression zone).

anchored at approximately 1 m within the compression zone.

Drilling of the composite material should be avoided. Where drilling is unavoidable, specific strengthening is required at the vicinity with the use of a special system whose efficiency shall be justified with reliable experimental tests.

Contact of the common steel with carbon fibers, should also be avoided in order to prevent galvanic corrosion.

This technique can be applied to slabs, beams and foundation elements and is generally not recommended for columns or shear walls (see § C.8.2.1.5). This technique ensures full anchorage of

In case that the tension zone of the structural member that is strengthened is likely to be subjected to compression under cyclic loading, appropriate additional measures are required (e.g. confinement of the region) in order to ensure that “local buckling” of the material will not occur. Otherwise, the application of this technique is not permitted.

- In case of steel laminates, it shall be ensured that the yield force of the strengthening reinforcement will be fully transferred, through dowels, to concrete.
- When composite materials are used, it should be foreseen to improve the anchorage at the ends of the laminates / fabric with the use of transverse strips or corner anchors or other special types of anchors with documented effectiveness.

viii) In any case, adequate fire protection measures are taken for all strengthening materials (fabrics or laminates).

b) Addition of a new reinforced concrete layer

- i) Enhancement of the flexural resistance of a R/C structural member can be achieved with new reinforcement, which is provided to the

the new reinforcement within areas under compression, preferably supporting members of the original structural system. In any case, the ability of the region to transfer the anchor forces has to be verified.

It is also possible to add a new layer at the compressive flange, thereby increasing (among others) the lever arm of the internal forces.

When more accurate data are not available, it is permitted to apply the approximate procedure of § C8.1.1.d under the conditions that: (a) the target final value of the flexural resistance does not exceed more than twice the initial one and (b) the measures taken at the construction site for bonding the new layer to the existing member include careful roughening of the surface of the member (jet with water and sand mixture or use of light air equipment, or electric needle) as well as the use of dowels, and/or anchors. Moreover, the works shall be carried out in accordance to the relevant technical specifications. Otherwise, it is recommended to apply the “Temporary National Technical Specifications (PETEP): Restoration Works of Structural Damage induced by the Earthquake and other harmful factors (Technical Chamber of Greece/IOK, 2008)”.

In this case, it is permitted to use the following values for the coefficient of monolithic connection:

- For slabs

$$k_k = 0,85, \quad k_r = 0,95, \quad k_{\theta y} = 1,15, \quad k_{\theta u} = 0,85$$

- For all other members

$$k_k = 0,80, \quad k_r = 0,85, \quad k_{\theta y} = 1,25, \quad k_{\theta u} = 0,75$$

flange under tension and is fully embedded within a new concrete layer.

- ii) In the determination of the flexural resistance and all other characteristics of the strengthened member, and upon lack of reliable methods for the assessment of the relative slip along the interface of the existing member and the new layer, it is provisionally permitted to use an approximate method after appropriate selection of the coefficients of monolithic connection.

For the welding of rebars the relevant provisions of the Steel Technology Standard apply together with any other relevant technical specification that is into force. It is also recommended to apply the “Temporary National Technical Specifications (PETEP): Restoration Works of Structural Damage induced by the Earthquake and other harmful factors (Technical Chamber of Greece/IOK, 2008)”. In case that the contact between the new and the existing rebar is not feasible and the connection has to be eccentric, other appropriate techniques can be used, provided that they are justified by adequate analytical and experimental data. The magnitude of the design shear force acting at the interface can be determined through equilibrium of the forces acting on the existing member or the new layer.

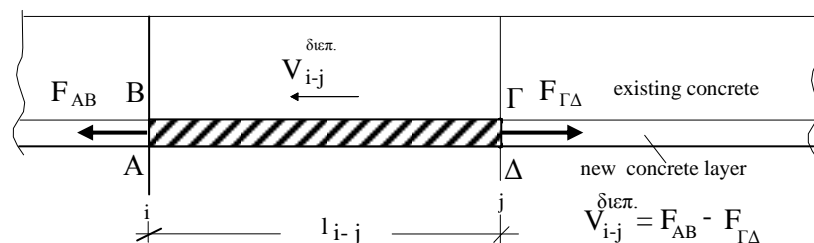

Figure C8.2: Shear force along the interface

In Figure C8.2, the value of the shear force along an interface with length l_{i-j} is determined by force equilibrium within the section ABΓΔA.

$$V_{sd(i-j)}^{\deltaιεπ.} = V_{sd}^{BΓ} = F_{AB} - F_{ΓΔ}$$

The value of forces F_{AB} and $F_{ΓΔ}$ are determined through the corresponding bending moment at sections i and j, as the tensile or

iii) The interface between the existing member and the additional layers can be verified as follows:

In the case of welding with existing reinforcement the implementation of the Steel Technology Standard provisions is sufficient, under the explicit condition that the available anchorage of the existing reinforcement is adequate to resist the total yield force of both the existing and the new reinforcement. Otherwise, the tensile yield strength of the new reinforcement is transferred to the strengthened structural member through dowels that penetrate the old-to-new concrete interface or through other casting arrangements.

compression forces that correspond to a section depth AB or ΓΔ. Sections i, j are typically taken: (a) at the location of maximum (positive or negative) bending moment (b) at the sides of the supports (c) at locations of application of concentrated loads (d) at locations of abrupt section change and (e) at the free edge of cantilevers.

The shear force along the interface $V_{Rd(i-j)}^{\delta_{\text{επ.}}}$ is determined according to § 8.1.2.3.

The new reinforcement is directly or indirectly anchored to the existing concrete members (through additional anchoring components). All the potential failure modes of these additional anchoring components that can be used (steel plates, anchors, dowels etc.) have to be verified. The relevant verifications for the direct or indirect anchorage can be made in compliance to § 6.1.2, which apply for bolts, anchors and rebars.

Due to the fact that in the case of slabs, full and extensive debonding is unlikely, the minimum interface shear reinforcement ratio is reduced by 50%.

iv) Sufficient anchorage of the additional tensile reinforcement within the structural members that are perpendicular to the strengthened member of the initial structural system has to be ensured, unless the additional reinforcement is welded on the existing reinforcement. In this case the sufficiency of the anchorage of the existing reinforcement is verified in compliance to the provisions of the previous paragraph (iii).

v) To ensure reliable shear strength at the interface it is necessary to provide a minimum interface shear reinforcement ratio ρ_{δ} :

$$\rho_{\delta, \min} = 0.20f_{ctm} / f_{yk} \geq 1.2\text{‰} \quad \text{in general} \quad (8.8a)$$

$$\rho_{\delta, \min} = 0.10f_{ctm} / f_{yk} \geq 0.6\text{‰} \quad \text{for slabs} \quad (8.8b)$$

where $\rho_{\delta} = \frac{A_{s\delta}}{A_{c\delta}}$, $A_{s\delta}$ is the area of the

transverse reinforcement, $A_{c\delta}$ the area of the interface and f_{ctm} the tensile strength of the strongest concrete part.

8.2.1.4 Interventions with the objective to strengthen the compression zone against flexure with axial force

- a) **Inadequacy of the flange in compression of a R/C structural member can be addressed with the addition of a new concrete layer on the compression flange.**
- b) **For the determination of the flexural resistance as well as of the other characteristics of the strengthened members, the provisions of § 8.2.1.3b (ii) apply.**
- c) **The interface between the existing member and the new layer is verified by assuming the section as monolithic through the relationship $\tau = \frac{V_{sd} S_y}{I b}$ where I is the moment of inertia and S_y the static moment of area of the additional section with respect to the center of gravity of the section) and b is the section width at the location of the interface.**
- d) **In terms of the minimum ratio of transverse**

The commentary related to the application of the simplifying method given in § C8.2.1.3b also applies in this case.

Alternatively, the magnitude of the design shear force acting on the interface may be determined by equilibrium of forces acting on the existing member or the new layer, in relevance to the commentary of § C.8.2.1.3b (iii).

reinforcement, § 8.2.1.3b (v) applies.

8.2.1.5 Column jackets with the objective of simultaneous strengthening in the tension and compression zone

The simultaneous inadequacy in both the flange in tension and the flange in compression may be addressed with the application of a closed jacket with longitudinal reinforcement that is well-anchored within the compression zones, preferably of an existing structural member. In any case, it should be verified that region has adequate capacity to transfer the anchorage forces. It is not recommended to add new concrete layers in the flange in tension or the flange in compression or both. Other techniques can also be used for undertaking part of the column internal forces, inclusive of column substitution.

b) The simultaneous inadequacy in both the flanges in tension and compression of a column may be addressed with the addition of a closed reinforced concrete jacket which surrounds the entire perimeter of the particular member.

- b) When strengthening is performed at the critical regions of columns, the jacket is extended to cover the area of the joints together with the critical region of the subsequent member beyond the joint. In case that the strengthening is extended to the edge critical regions of beams as well, the capacity design verifications are repeated (if were applicable in the first place) because it is possible to be found critical.**
- c) Transfer of forces from the initial structural member to the jacket has to be ensured with appropriate construction measures and to be**

verified analytically.

- d) **When a more rigorous method is not applied, the requirements of the above paragraph are deemed to be satisfied upon application of the provisions below:**
- i) The initial section and the jacket section are considered as a single monolithic section.
 - ii) The jacket section is verified to be able to resist the allocated normal and shear forces by taking into account:
 - potential damage of the initial member of the degree of their rehabilitation
 - the conditions of shoring and confinement towards load transfer after the intervention and
 - the potential stress redistribution after the intervention.
 - iii) Safe force transfer from the initial member to the jacket as well as compatibility of deformations at the interface is verified according to the following paragraphs “e” and “f”.

The compression force F_{cm} of the jacket can be approximately estimated as:

$$F_{cm} = \frac{N_v + N_E}{2} + F_M = \frac{N_v + N_E}{2} + \frac{M_n}{z} \quad (C.8.6)$$

where $z = 0,9d$ and d is the depth of the strengthened section.

The assemblage length u_o can be taken equal to the half of the net column height and in any case, not greater than: $u_{o,max} = F_{cm} \cdot 4 f_{ctm} t$.

When the jacket is constructed around damaged columns (which should have been repaired anyway), the assemblage length u_o at each edge of the jacket cannot be considered greater than the distance between the location of the first undamaged section and the end of the jacket.

When the available assemblage length at the jacket edge is inadequate to transfer the compressive force to the jacket (as it is likely to occur in case that the damage is near the edge of the member), it is possible that additional construction measures will be required to ensure direct transfer of the compression force from

- e) **The shear force along the interface between the jacket and the existing column is the resultant of the following acting forces:**
- i) Axial force (N_v) due to the additional vertical loads of the jacket after the intervention and to removal of the shoring.
 - ii) Axial force (N_E) that acts on the jacket due to seismic loading.
 - iii) Force (F_M) that is induced by the bending moment (M_n) that will be applied after the intervention.
- f) **The compressive force F_{cm} of the jacket is safely transferred as a shear force along the interface through friction, welded suspensors and dowels, within an available assemblage length “ u_o ” provided that:**

$$F_{cm} \leq V_{Rid} \quad (8.9 \text{ a})$$

where:

$$V_{Rid} = 4u_o \mu f_{ctm} t + 10n_b \frac{A_{sb}}{h_s} + n_D F_{ud} \quad (\text{kN}, \text{ mm}) \quad (8.9 \beta)$$

- u_o is the assemblage length at each edge of the jacket
- μ the concrete-to-concrete friction coefficient

the existing members (that are located at the edge of the strengthened member) to the jacket.

due to low normal stresses which in this case can be taken equal to unity

f_{ctm} the mean tensile strength of the jacket concrete

t the jacket thickness

n_b and n_D the total number of suspensors and dowels respectively, which are arranged within the compression zone at each edge of the jacket along the length of the initial member.

A_{sb} the cross-sectional area of the suspensor

h_s the distance between the initial reinforcement of the member and the new reinforcement at its vicinity

F_{ud} the resistance of a dowel as derived according to § 6.1.2.

- g) **In order to transfer the tensile cracking stresses along the edges of the jacket, dense hoops shall be provided within the length u_o , to undertake as a minimum, the force that corresponds to the transverse tensile strength of concrete. The minimum hoops required are controlled by the relationship:**

$$\frac{A_{sw}}{\alpha_{sw}} \geq \frac{t \cdot f_{ctm}}{f_{ywd}} \quad (8.10)$$

where:

A_{sw} is the cross-sectional area of the hoop,

α_{sw} is the hoop spacing,

f_{ywd} is the strength of the hoops,

The maximum distance between the stirrups α_{sw} can be calculated as:

$$\alpha_{sw} \leq 0,8 \left(\frac{f_{ywd}}{f_{ctm}} \right) \cdot \frac{d_h^2}{t} \quad (\text{C8.7})$$

Pre-existing damage shall be in any case repaired.

When more accurate data are not available #8 hoops @75 mm spacing is provided.

When a more accurate method is not applied, it is permitted to follow the simplifying procedure (§ C8.1.1δ), under the condition that: (a) the target flexural resistance of the member does not exceed more than twice the initial one and (b) the measures taken at the construction site for bonding at the interface the jacket and existing member include careful roughening of the surface of the member (jet with water and sand mixture or use of light air equipment, or electric needle) as well as the use of dowels, and/or suspensors. Moreover, the works shall be carried out in accordance to the relevant technical specifications. Otherwise, it is recommended to apply the “Temporary National Technical Specifications (PETEP): Restoration Works of Structural Damage induced by the Earthquake and other harmful factors (Technical Chamber of Greece/IOK, 2008)”.

In this case, it is permitted to use the following values of the coefficient of monolithic connection:

$$k_k = 0,80 \quad , \quad k_r = 0,90 \quad , \quad k_{\theta y} = 1,25 \quad , \quad k_{\theta u} = 0,80$$

It is clear that damage in the column shall be restored prior to the construction of the jacket. Nevertheless, in case that this damage is extensive, the repair itself does not necessarily and without any doubt restore the bearing capacity of the existing column.

In a region of pre-existing damage, it is required to provide dense hoops in order to avoid premature buckling of the new longitudinal reinforcement.

- h) **When more reliable methods for assessing the relative slip along the interface between an existing member and the added layers is not available, it is provisionally permitted to implement the simplifying approach with appropriate selection of monolithic connection coefficients in order to calculate the flexural resistance and the other characteristics of the strengthened member.**
- i) **The case that an existing column is extensively damaged and it has been decided not to account its bearing carrying anymore, the construction of the jacket is deemed equivalent to the addition of a new "hollow" column.**

In this case, special care shall be given to ensure

the full transfer of the internal forces of the existing column also to the existing structural members that are linked to the edges of the “new” column.

8.2.2 Interventions with the objective to increase the shear capacity

8.2.2.1 Inadequacy against crushing of the compression struts

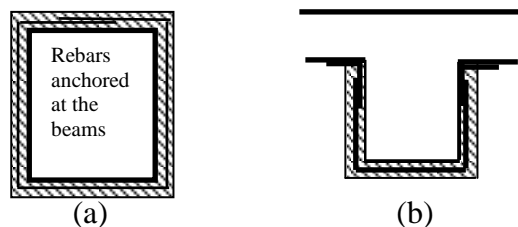

Figure C8.4: Indicative means of strengthening against diagonal compression: (a), closed-form strengthening, (b) open strengthening with strong end connection

In cases where the construction of a jacket (i.e. “closed-form strengthening”) (Fig. 8.4a) is not feasible, the addition of new concrete layers in the form of an “open”-form strengthening, shall cover, as a minimum, the three faces of the initial member (Fig. 8.4 b). In this case, it shall be analytically verified that adequate anchorage of the ends of the jacket is provided on the existing concrete members. It is also required to verify the strengthening to

- i) **Inadequacy of a R/C member to shear due to crushing of the compression strut ($V_{Sd} > V_{Rd,max}$, where $V_{Rd,max}$ as defined in EC2) is addressed either with the use of confinement or with the addition of new concrete layers, preferably in the form of jacket.**
- ii) **In case of confinement, the design shear resistance to crushing of the compression strut $V_{Rd,max}$ is calculated according EC2 (§ 6.2.3) with the use of an increased compression strength of the confined concrete that is in turn determined on the basis of § 6.2 of the present Standard.**
- iii) **In case that additional new layers or a concrete jacket the following safety verification is made:**

$$V_{Sd} \leq \frac{1}{\gamma_{Rd}} (V_{Rd,r} + V_{RM}) \quad (8.11)$$

where:

V_{Sd} is the design shear force

all the potential modes of failure of both the anchorage components and their supports.

$V_{Rd,r}$ and V_{RM} are derived on the basis of EC2 (§ 6.2.3). In case of a damaged member, $V_{Rd,r}$ can be estimated according to § 7.3 of the present Standard.

It can be taken that $\gamma_{Rd} = 1,25$.

The confinement techniques that are presented in § C.8.2.3 represent suitable strengthening procedures against shear for linear members (primarily columns).

The external components may be of the form of bonded sheets or collars (external stirrups). In case that steel is used, the collars shall consist of either rebars or laminates, while in the case of FRPs, they can be either fabric strips or laminates.

It is recommended to prefer “closed-form” strengthening measures in the form of full-sided jackets that surround the entire section of the member. In case that this is not feasible it is required to fully anchor the transverse reinforcement of the “open” jacket within the existing concrete using additional connection components of

$V_{Rd,r}$ is the shear resistance $V_{Rd,max}$ of the initial member

V_{RM} is the shear resistance $V_{Rd,max}$ of the additional layers or the jacket

γ_{Rd} is a safety factor covering the uncertainties that are related to the simultaneous mobilization of both the above resistances.

8.2.2.2 *Inadequacy of transverse reinforcement*

- i) **Strengthening of a R/C member against shear that becomes necessary due to inadequacy of the transverse reinforcement ($V_{Sd} > V_{Rd3}$), can be achieved either with reinforced concrete jackets or with the use of external steel components or fiber reinforced polymers which are fully bonded on the member, thus undertaking the role of transverse reinforcement, in a similar manner to the corresponding conventional reinforcement.**

adequate capacity to transfer the forces to the initial member. In any case, the application of “open” strengthening measures is not permitted using independent laminates or FRP fabrics bonded on the sides of the member: “Open” strengthening measures are only permitted in the form of a continuous U.

As an exception, it is permitted to apply “open” strengthening measures through anchorages without additional connection components and solely through the use of epoxy resin under the following conditions: (a) the height of the initial member that is available for the bonding of the strengthening component is adequate for the transfer of the force that is required to be resisted by the new stirrups. The above prerequisite is deemed to be satisfied $h \geq h_j \geq 2L_e$ where h and h_j is the height of the initial member and the strengthening component respectively, and L_e is the effective anchorage length as defined in eq. C8.4 (b) the capacity of the initial member without any strengthening is adequate for the load combination $G+\psi_2 Q$, and (c) the quality control of the works is of high standard.

- ii) **In case of strengthening with additional layers or reinforce concrete jackets, the previous provision §8.2.2.1(iii) applies.**
- iii) **In case of strengthening with external steel components or FRPs, the shear resistance due to the yielding shear reinforcement ($V_{Rd,tot}$) can be calculated by the following relationship:**

See EC2 (§ 6.2.3)

This ratio is defined as:

$$\rho_j = \frac{2A_j}{s_j b_w \sin \alpha} \quad (\text{C8.8})$$

where $A_j = t_j w_j$

t_j is the thickness of the external reinforcement.

w_j and s_j is the width and axial spacing of the external reinforcement in the case of strips

For continuous sheets $t_j = \frac{A_j}{s_j}$, $w_j = s_j$

for $\theta = 45^\circ$ and $\alpha = 90^\circ$ the expression is simplified:

$$V_{Rd,tot} = V_{Rd,s} + V_{jd} \quad (8.12)$$

where

$V_{Rd,s}$ is the shear force undertaken by the transverse reinforcement of the initial member

V_{jd} is the shear force undertaken by the new transverse reinforcement

$$V_{jd} = \sigma_{jd} \rho_j b_w h_{j,ef} (\cot \theta + \cot \alpha) \sin^2 \alpha \quad (8.13)$$

where:

σ_{jd} is the design value of the effective stress of the externally provided transverse reinforcement.

ρ_j is the shear reinforcement ratio

b_w is the width of the section

$$V_{jd} = \sigma_{jd} \rho_j b_w h_{j,ef} = \frac{2 A_j}{s_j} h_{j,ef} \sigma_{jd} \quad (C8.9)$$

It can be assumed that $h_{j,ef} = 2/3 d$ where d is the depth of the section.

In case that the strengthening is performed using FRPs, the angle α is the angle of the principle fibers of the polymer with respect to the longitudinal axis of the member. In case of materials with fibers along more than one principle directions, eq. (8.13) shall be applied independently for each principle fiber direction (with an appropriate ρ_j).

In case that the strengthening material is steel, the value of the safety factor γ_m is determined according to the provisions of § 4.5.3.2a and it is assumed that $f_{jk} = f_{syk}$.

In case that the strengthening material is FRP, it is taken that $\gamma_m = \gamma_{FRP} = 1,2$ (in simultaneous compliance with the provisions

$h_{j,ef}$ is the effective (in terms of shear transfer) depth of the strengthening

θ is the angle between the axis of the member and the direction of the anticipated diagonal cracks, that can be taken equal to 45° .

α is the angle of the external transverse reinforcement with respect to the longitudinal axis of the member.

- iv) **The design value of the effective stress σ_{jd} , of the new transverse reinforcement, is estimated on the basis of a critical value of stress $\sigma_{j,crit}$ or deformation $\varepsilon_{j,crit}$ of the strengthening material that depends on the mode of failure. As design value σ_{jd} is considered the value that corresponds to the most critical of the two modes of failure.**

A) Failure of the strengthening material.

To be avoided, it should be ensured that:

$$\sigma_{jd} \leq \frac{1}{\gamma_m} \cdot f_{jk}, \quad (8.14)$$

where:

of § 4.5.3.2b) and

$$f_{jk} = E_j \varepsilon_{j,crit} ,$$

where E_j is the modulus of elasticity of the strengthening material.

When FRPs are used, failure of the material may occur under deformations that are significantly lower than the conventional ultimate deformations of the material (as it has been shown by tests under axial tension), due to local overstress at the location that bridges the wider opening of a critical shear crack. To tacked this unfavorable possibility, it is taken that:

$$\varepsilon_{j,crit} = k_v \varepsilon_{j,max} ,$$

where k_v is a coefficient that expresses the approximately triangular distribution of the deformations along the critical diagonal crack and is taken equal to $k_v = 1/2$.

It also applies that:

$$\varepsilon_{j,max} = \varepsilon_{ju} \psi \leq 1.5\% ,$$

where

ε_{ju} is the maximum tensile deformation of the material and

ψ is a reduction coefficient considering the influence of multiple layers (see § 6.2.3).

The maximum value $\varepsilon_{j,max} = 1.5\%$ aims to limit the opening of a critical diagonal crack beyond which the contribution of concrete (V_c) to the member shear resistance is reduced and failure occurs prior to the exhaustion of the resistance of the strengthening material.

This mode of failure concerns only the exceptionally permissible open-form strengthening techniques that do not have additional anchorage components at their edges while their anchorage is

f_{jk} is the characteristic strength of the strengthening material και
 γ_m is the partial safety factor for the strengthening material.

B) Premature debonding of the strengthening material due to inadequate anchorage of its edges.

ensured solely through bonding with epoxy resin (see § C8.2.2.2(i)).

In case of “closed” strengthening measures, this mode of failure is prevented by ensuring the continuity of the strengthening component along the perimeter. If the strengthening component is made of FRP then the continuity along the perimeter is deemed to be satisfied through sufficient (of the order of 150mm) overlapping of the two edges of the FRP fabric. If the material is steel, then the continuity is considered to be satisfied through welding or mechanical links whose strength shall be in any case verified analytically.

“Open” strengthening measures can be deemed as quasi-“closed” when the full anchorage of their edges on the existing concrete members is ensured, after verification of all potential modes of failure of the anchoring components.

The safety factor for modeling uncertainty γ_{Rd} , is taken equal to 1,2.

The values of $\sigma_{j,crit}$ or $\varepsilon_{j,crit}$ are determined with the use of reliable data available in the international literature. In the absence of such data, it can be assumed that:

$$\sigma_{j,crit} = k_v \cdot \sigma_{j,max}$$

with:

$$k_v = 0,40 + 0,25\lambda \leq 0,65$$

where

$L_{av} = h_{j,ef}$ is the available anchorage length of the strengthening reinforcement and

L_e is the corresponding effective anchorage length (i.e., the anchorage length beyond which the force that can be

To prevent this mode of failure, the following condition applies:

$$\sigma_{jd} \leq \sigma_{j,crit} : \gamma_{Rd}, \quad (8.15)$$

where

γ_{Rd} is the appropriate safety factor quantifying the uncertainties of the finite element model.

transferred by the strengthening material does not increase) and can be taken from the expression (C8.4) :

$$L_e = \sqrt{\frac{E_j t_j}{2f_{ctm}}} \quad (\text{MPa, mm})$$

$$\sigma_{j,\max} = \beta \frac{\tau_b^{\alpha_{\text{ποκ.}}}}{t_j} L_e \quad (\text{C8.10})$$

$$\tau_b^{\alpha_{\text{ποκ.}}} \cong f_{ctm}$$

t_j is the thickness of the strengthening material. In case that k successive layers of the strengthening material of thickness t_{j1} are used, it applies that $t_j = \psi k t_{j1}$, where $\psi < 1$ is the multiple layers reduction coefficient (§ 6.2.3).

$\beta = \beta_w \beta_L$ correction factors

$$\beta_w = \sqrt{\frac{2 - \frac{w_j}{s_j} \sin a}{1 + \frac{w_j}{s_j} \sin a}} \quad \text{coefficient for the influence of the width of}$$

the strengthening reinforcement, equal to $\frac{1}{\sqrt{2}}$ for the case of strengthening with continuous sheets or fabrics.

$$\beta_L = \sin\left(\frac{\pi\lambda}{2}\right) \cong \lambda(2 - \lambda), \quad \text{coefficient of influence of the available}$$

anchorage length, with

$$\beta_L = 1 \quad \alpha \nu \quad \lambda \geq 1,0 .$$

- v) **For members with circular cross-section, V_{jd} is calculated by the equation:**

$$V_{jd} = \sigma_{jd} \rho_j \frac{1}{2} \frac{\pi D^2}{4} (\cot\theta + \cot\alpha) \sin^2 \alpha, \quad (8.16)$$

where:

ρ_j is the volumetric ratio of the external transverse reinforcement, which in the case of strips or collars is equal to $4A_j / D.s_j \cdot \sin \alpha$ while in the case of full-sided jackets is $4t_j / D \cdot \sin \alpha$

D is the diameter of the section

$A_j = t_j w_j$ is the cross-sectional area of the transverse reinforcement

The design value of the effective stress σ_{jd} of the transverse reinforcement is calculated according to the provisions of §(iv).

- vi) In any case, when external collars or strips are used, their maximum axial spacing is defined according to the provisions of EC2 and EC8 regarding the minimum hoop spacing.**
- vii) **This technique is not applied when the width of the structural member b_w is greater than the minimum spacing between the hoop's legs as prescribed in EC2.**

This technique is primarily used in columns and it is convenient for members with circular or rectangular cross sections of relatively small dimensions, with a height to width ratio that does not exceed 2:1.

It is indicatively reported that the application of external confinement can be performed in the following ways:

- Addition of bonded collars that can be either steel laminates of typical thickness of 1-2 mm or FRP strips.
- Use of prestressed, steel or FRP collars.
- Use of spiral reinforcement consisting of either a steel laminate or an FRP.
- Addition of a full-sized jacket by sheets of steel laminates or fiber reinforced fabrics bonded on the member sides. The steel laminates can have a wave shape (with the ribs orientated along the horizontal direction) due to their increased transverse stiffness, hence, it is permitted to appropriately take into consideration their favorable effect on confinement efficiency (i.e., in terms of α_n increase) as a function of the moment of inertia of the laminate. In case of steel jackets, this technique can be applied by arranging steel sheets at small distances from the member edges and subsequently fill the void with non-shrinking grout under pressure. This technique is particularly efficient when the steel jacket has an elliptical or circular shape. The use of shrinking grout as a void fill material can additionally provide some initial (active) confinement to the member.
- Use of a steel reinforcement cage that is formed by vertical L-shaped laminates in conjunction with dense horizontal

8.2.3 Interventions with the objective to increase local ductility

a) The increase of local ductility in linear structural members is achieved by imposing external confinement or with the application of a reinforced concrete jacket.

Prerequisite of application of the method is that the capacity design verification checks prescribed in Chapter 9 are satisfied after the intervention, after appropriate consideration of the confinement-induced increase in resistance.

When the technique includes that addition of new vertical components (such as steel, L-shaped laminates in the case of a steel reinforcement cage), which are then to responsible to resist part of the axial load, it is necessary to verify their capacity to transfer the loads from the initial structural system. In case that the friction mechanism to be developed due to confinement is inadequate to transfer these forces, additional measures are required to ensure connection (i.e., dowels).

steel collars or complete steel sheets.

It is recalled that when the required values of $\mu_{1/r}$ entail disproportionately uneconomic ductility in certain structural members, the possibility shall be examined to combine the application of the method with the strength enhancement of the particular members or with the addition of new members to the structure.

The elastic analysis with the “q” method is feasible when the prerequisites of § 5.5.2 are satisfied.

In the absence of more precise methods, the assessment of q_v can be performed on the basis of the relevant values provided in Appendix A.2. of Chapter 4.

- b) The above ductility-induced increase in ductility and strength of the existing concrete is taken into account as prescribed in § 6.2 of the present Standard.
- c) The required mechanical volumetric ratio of confining hoops (ω_{wd}) is determined as a function of the target value of curvature ductility $\mu_{1/r}$ (see below §d και §e).

- δ) When the redesign objective is expressed in terms of the global behavior factor “q”, it shall be verified that all structural members have the capacity to exhibit local ductility factors “m” that are adequate to develop this global behavior factor q.

To this end, the following calculation process applies:

- i) Taking into account the overstrength factor q_v of the structure, the required ductility factor can then be derived
 $q_\pi (=q : q_v)$
- ii) The required displacement ductility factor μ_d of the structure is:

$$\mu_\delta = \begin{cases} q_\pi & \text{when } T > T_c \\ 1 + (T_c/T)(q_\pi - 1) & \text{when } T < T_c \end{cases} \quad (8.17)$$

where T_c is the corner period beyond which the descending branch of the design spectrum initiates.

To this end, it is possible to locate the most vulnerable primary structural member of each storey (with the maximum index λ), which shall be redesigned for the required local displacement ductility factor equal to “ μ_δ ”, whereas all the other primary members of storey “i”, shall exhibit a local displacement ductility

index equal to $\mu_{\delta i} = \frac{\lambda_i}{\lambda_{\max}} \mu_\delta$, where:

λ_i is the failure index of the primary structural members (as defined in § 5.5.1.1) after the intervention and

$$\lambda_{\max} = \max \lambda_i$$

It is noted that if, according to the judgment of the designer, the above most vulnerable primary member does not bear a significant part of the storey forces, it is possible to initiate the same procedure using another member “k” exhibiting critical behavior with $\lambda_k < \lambda_{\max}$.

To this end, it is permitted to use the expression $(\mu_{1/r}-1): (\mu_\delta-1)=3$. It is noted that in case the available value of “q” is estimated on the basis of available values of $\mu_{1/r}$, then the following relationship is conservatively used $(\mu_{1/r} - 1): (\mu_\delta - 1)=2$.

For $v > 0,2$, it is alternatively permitted to use the approximate expression

$$\varepsilon_{cu,c} = 2,2 \mu_{1/r} \varepsilon_{sy} v \not\leq 0,0035 \quad (C8.11)$$

where ε_{sy} is the yield strain of the longitudinal reinforcement of the member and “v” is the normalized compressive axial force, both calculated on the basis of mean values of the particular

iii) It shall be verified that each storey of the building can exhibit the above ductility factor μ_δ , by calculating the required factors $\mu_{\delta i}$ of each individual primary member of the respective storey.

iv) For each critical section of the primary structural member the required value of the curvature ductility factor $\mu_{1/r}$ is calculated as a function of the corresponding displacement ductility $\mu_{\delta i}$, μέσω through reliable correlations.

v) Finally, the value of $\alpha \omega_w$ is analytically sought so that in the bending-moment diagram of the section examined the following relationship applies: $(1/r)_u : (1/r)_r = \mu_{1/r, \alpha \pi}$. To this end, the modified, due to confinement, stress-strain relationship of concrete is taken according to § 6.2:

member. The required value of $\alpha\omega_{wd}$, that corresponds to $\mu_{1/r,\alpha\pi.}$, is calculated with the use of eq. (8.18) to (8.20).

Steel confinement

$$\varepsilon_{cu,c} = 0,0035 + 0,1\alpha\omega_{wd} \quad (8.18)$$

Confinement with Carbon FRP

$$\varepsilon_{cu,c} = 0,0035 (f_{c,c} : f_c)^2 \quad (8.19)$$

Confinement with Glass FRP $\varepsilon_{cu,c} = 0,007 (f_{c,c} : f_c)^2$
(8.20)

$$\text{where } f_{c,c} = (1,125 + 1,25\alpha\omega_{wd}) f_c$$

- e) When the redesign objective is expressed in terms of the local member ductility “m”, it shall be verified that the available ductility at the critical regions of each primary structural member is adequate to ensure the given objective of the particular member, according to the previous d(iii).

For calculating the required values of $\mu_{1/r}$, the aforementioned provisions § d(iv) και (v) apply with the difference that for each structural member $\mu_{\delta,\alpha\pi.}$ is substituted by $m_{\alpha\pi.}$

- f) When the redesign objective is expressed in terms of the desirable chord rotation “ θ_d ”, the required curvature ductility $\mu_{1/r}$ of each structural member, can be calculated through reliable expressions that correlate $\mu_{1/r}$ and μ_θ , so that the necessary confinement can be calculated according to the above paragraph § d(v).

- g) When individual external collars (strips) are used as confinement reinforcement, their maximum axial spacing

Based on the commentary of § 8.2.3d(iv), the following relationship can be used: $\mu_{1/r} = 3\mu_\delta - 2$ or alternatively

$\mu_{1/r} = 2\mu_\delta - 1$ when the values of θ_d will be reversely calculated from available values of $\mu_{1/r}$.

Besides, according to § 6.5 $\theta_d = \mu_\theta \theta_y$, where θ_y is estimated by § 7.2.2(d) whereas correlation of μ_θ and μ_δ is performed through the relationships of § 7.2.6, depending on the foreseen failure mode of the structure.

In case of a steel reinforcement cage, it is sufficient to satisfy the relationship $s \leq 0,5b_c$

is defined as

$$s_{\max} = 100 + w_j \text{ (mm)} \leq 0,5b_c$$

where w_j is the width of the collar and b_c the smaller of the two dimension of the section.

For interventions with new concrete layers see § 8.2.1.3β, § 8.2.1.4 and § 8.2.1.5.

8.2.4 Interventions with the objective to increase stiffness

Stiffness increase of a R/C structural member by adding new concrete layers, or new external components can be analytically estimated assuming that the member is composite, or approximately, using coefficients of monolithic connection provided that reliable data are available for this purpose.

Regarding the verification of the joint resistance see § 7.2.5
Interventions in frame joints may be required in case of insufficient anchorage length of the longitudinal rebars of the structural members that are connected to the joint. In this case, it is recommended to extend the particular structural members to ensure the required anchorage length of the reinforcement or to improve the anchorage conditions by applying confinement with cross collars or with the construction of a reinforced concrete jacket.

8.3 INTERVENTIONS TO FRAME JOINTS

The inadequacy against shear of a beam-column joint (or of beam-shear wall joint) may be attributed to either exceedance of the joint resistance in diagonal compression or to lack of reinforcement (joint hoops).

It is recommended to sufficiently extend the joint strengthening to all the connected structural members and to analytically verify that these members can transfer their internal forces to the added materials.

The construction measures at the interface between the jacket and the existing member include the thorough roughening of the surface of the member and the use of dowels and/or suspensors, while the works shall be conducted according to the relevant technical specifications. Otherwise, it is recommended to apply the “Temporary National Technical Specifications (PETEP): Restoration Works of Structural Damage induced by the Earthquake and other harmful factors (Technical Chamber of Greece/IOK, 2008)”. Under the above conditions, the coefficient of monolithic connection (k_r) for the calculation of the resistance, can be taken equal to 0,85.

Selection of the strengthening technique of the joint strongly depends on the construction options available in each case. For instance, the presence of slabs and transverse beams usually makes it impossible to apply the technique of bonded laminates or FRP fabrics or cross collars. In the case of a damaged joint, the “equivalent” section rehabilitation technique (see § S.8.2.1) may be

8.3.1 Inadequacy due to diagonal compression of the joint

Strengthening of a joint against failure due to diagonal compression is performed by increasing its dimensions through the construction of a reinforced concrete jacket. The adequacy of the strengthening measures is verified according to § 7.2.5, by taking into account the dimensions of the strengthened joint and $\gamma_{Rd} = 1$.

8.3.2 Inadequacy of joint reinforcement

Reinforcement inadequacy in a joint may be addressed through strengthening with reinforced concrete jackets or cross collars made of steel components or bonded steel laminates or FRP fabrics or with the addition of new, horizontal and vertical ties.

combined with the addition of new reinforcement (stirrups) at the joint. Regardless of the technique chosen, the commentary of § 8.3.1 also applies herein.

The reinforced concrete jacket constructed in frame joints is often the extension of the jacket that has already been used to strengthen the vertical member of the joint.

For calculating V_{jh} and V_{jv} , βλ. Σ.7.2.5.

If $\Sigma M_{yb} < \Sigma M_{yc}$, then the horizontal shear force (V_{jh}) is derived by eq. C.8 (§ 7.2.5) while the vertical shear force (V_{jv}) is obtained from:

$$V_{jv} = V_{jh} \frac{h_b}{h_c}$$

(Σ8.12)

If $\Sigma M_{yc} < \Sigma M_{yb}$, then the vertical shear force V_{jv} is derived by eq. C.9 (§ 7.2.5) while the horizontal shear force (V_{jh}) is obtained from:

$$V_{jh} = V_{jv} \frac{h_c}{h_b}$$

(Σ8.13)

The value of γ_{Rd} can be taken equal to 1,5.

8.3.2.1 Construction of a reinforced concrete jacket at a joint

The adequacy of the strengthening is initially verified according to eq. (3) or (4) of § 7.2.5 by taking into account the dimensions of the strengthened joint. In case that the dimensions of the existing joint do not ensure avoidance of diagonal tension cracking, the horizontal reinforcement of the jacket at the joint region is calculated by the relationship:

$$A_{jh} = \frac{V_{jh}}{f_{ywd} \gamma_{Rd}} \quad (8.21)$$

while the vertical reinforcement is calculated from the relationship:

$$A_{jv} = \frac{V_{jv}}{f_{ywd} \gamma_{Rd}} \quad (8.22)$$

where V_{jh} and V_{jv} the horizontal and vertical shear force that is acting within the joint.

The collars are placed crosswise and are stressed by mechanical means. By confining the joint region its ductility is increased, while the anchoring conditions of the longitudinal rebars of the connected beams are also improved. It is recommended to apply this technique to external joints by expansion of the beam ("hump technique"). In case that the vertical member does not extend to the upper storey, this member is also extended. The tensile force $F_{j\delta}$ can be calculated from the relationship:

$$F_{j\delta} = \frac{V_{jh}}{h_c} h_\delta = \frac{V_{jv}}{h_b} h_\delta$$

(C8.14)

where h_δ is the length of the joint diagonal.

The values of the shear forces V_{jh} and V_{jv} are calculated according to § C.8.3.2.1.

The value of γ_{Rd} can be taken equal to 2.

The technique is applicable only in the form of "quasi-closed" strengthening measures that surround the body of the joint to ensure the full anchoring of their ends within

8.3.2.2 Addition of steel cross collars in a joint

The required section of the steel components in each diagonal direction is determined as follows:

$$A_{j\delta} = \frac{F_{j\delta}}{\gamma_{Rd} f_{yd}} \quad (8.23)$$

where $F_{j\delta}$ is the diagonal tensile force acting within the joint.

8.3.2.3 Addition of bonded steel laminates or FRP fabrics in a joint

The thickness of the laminate or fabric shall be sufficient to transfer the horizontal and vertical shear.

the existing concrete members that are connected to the joint. All the potential failure modes of the anchoring components shall be verified (see § 6.1.4).

The steel sheets can have a wave shape due to their increased transverse stiffness.

It is recommended to use fabrics with fibers orientated along two principal directions, which satisfy the requirements regarding the thickness per each direction.

Comparatively see § C8.2.1.1

For the case of strengthening with steel laminates, their required thickness is determined by the relationship:

$$t_{e\lambda} \geq \max\left(\frac{V_{jh}}{h_b \sigma_{jd}}, \frac{V_{jv}}{h_c \sigma_{jd}}\right) \quad (8.24)$$

For the case of FRP fabrics, the thickness of the required fabric having fibers parallel to the beam axis, is determined as $t_{jh} = \frac{V_{jh}}{h_d \sigma_{jd}}$ while the

thickness of the fabric having fibers parallel to the column axis, is determined as $t_{jv} = \frac{V_{jv}}{h_c \sigma_{jd}}$

The design value of the effective stress of the strengthening reinforcement (σ_{jd}), is determined according to § 8.2.2.2(iv).

8.3.2.4 Restoration of “equivalent” section and reinforcement addition in a joint

In the case of a damaged joint, the “equivalent” section restoration technique can be adopted by adding horizontal and vertical ties. The total cross section of the horizontal and vertical hoop legs

The values of the shear forces V_{jh} and V_{jv} are calculated according to § C.8.3.2.1.

It is taken that $\gamma_{Rd} = 1,5$.

$A_{jh,tot}$ and $A_{jv,tot}$, respectively, is determined by the following relationships:

$$A_{jh,tot} \geq \frac{\gamma_{Rd} V_{jh}}{f_{ywd}} \quad (8.25)$$

$$\text{and } A_{jv,tot} \geq \frac{\gamma_{Rd} V_{jv}}{f_{ywd}} \quad (8.26)$$

8.4 INTERVENTIONS ON SHEAR WALLS

8.4.1 Interventions on a shear wall with a capacity objective against bending with axial force

8.4.1.1 Local restoration of a damaged region

The referred in § 8.2.1.1. respectively apply.

8.4.1.2 Restoration of insufficient starter bars

When the available lap length of the reinforcing bars within the regions of overlapping is insufficient, it is possible to ensure force transfer between the rebars by welding them or by adding external reinforcement to the member, in accordance with those specified in § 8.2.1.2.

The commentary of § 8.2.1.2(a) apply.

Indicative strengthening means are the:

- addition of edge columns
- one-sided strengthening and addition of edge columns.

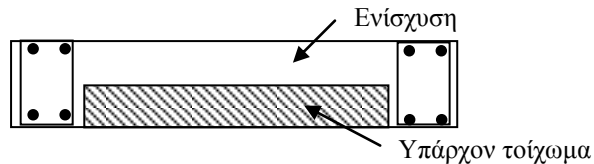

Figure C8.5: Indicative arrangement of a one-sided shear wall strengthening

- The full-sided closed jacket which typically include face-to-face links (“ties”) that connect the bilateral concrete parts in conjunction with the formation of “hidden” columns at the edges of the shear wall (preferable strengthening measure).

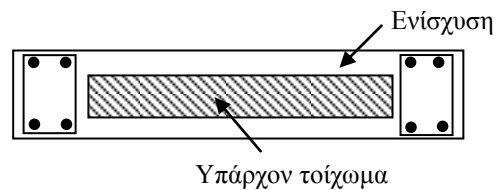

Figure C8.6: Indicative arrangement of a full-sided, closed jacket, shear wall strengthening

8.4.1.3 Interventions with the objective to increase the in-plane flexural capacity

- a)** Inadequacy of a shear wall in flexure is addressed with the addition of new reinforced concrete sections in the tension and compression zone.

- b)** For the design of the shear wall that is strengthened, the provisions of § 8.2.1.5 apply, while the provisions of § 8.4.5 apply for the verification of the interfaces.

8.4.2 Interventions with the objective to increase the shear capacity of a shear wall

The additional lateral layers of concrete are connected with anchor clamps, solidly anchored at both faces to improve the shear resistance at the interface(s).

8.4.2.1 *Inadequacy against diagonal compression of the web*

Inadequacy of a shear wall against diagonal compression of the web ($V_{Sd} > V_{Rd2}$) can be addressed by adding new layers of concrete, preferably in the form of a jacket. For the design of the strengthened shear wall and the verification checks at the interfaces, the provisions of §§ 8.2.2.1 and 8.4.5 respectively apply.

8.4.2.2 *Inadequacy of the transverse reinforcement*

Shear strengthening of a shear wall that is deemed necessary due to inadequacy of the transverse reinforcement may be achieved by one of the following techniques:

- i) with reinforced concrete jackets
- ii) with external steel components or fiber reinforced polymers that are bonded to or encase the member, thus acting as shear reinforcement in a similar manner to the conventional reinforcement.

The requirements for the implementation of these intervention techniques follow the corresponding ones that refer to linear structural members (§ 8.2.2).

For the design of the strengthened shear wall and the verification checks at the interfaces, the provisions of §§ 8.2.2.2 and 8.4.5 respectively apply.

8.4.2.3 *Shear wall sliding*

Shear wall sliding at the location of construction joints may be addressed by adding either a jacket locally (with appropriately anchored reinforcement) or vertical steel components well-anchored at both sides of the construction joint.

8.4.3 **Interventions with the objective to increase ductility**

Methods for increasing the ductility of structural members, such as those mentioned in § 8.2.3 cannot be easily applied to shear walls. In any case, the significant available resistance of the shear walls, especially after the intervention can meet the design requirements with relatively smaller values of local ductility demand.

Also see C.8.4.5.

- a) Increase of the section dimensions at the compression flange (by adding a transverse shear wall or with the local expansion of the wall in the form of an “edge column”) can increase the ductility of the shear wall.
- b) In case that additional transverse clamps are provided,

apart from the ones required according to the verification checks at the interfaces, it is permitted to take into consideration the beneficial effect of transverse compression on ductility.

8.4.4 Interventions with a stiffness increase objective

The corresponding provisions of § 8.2.4 apply.

8.4.5 Verification at the interfaces of strengthened shear walls

The vector difference between the resultant of all forces that are resisted by the entire strengthened shear wall and the ones that were resisted by the existing shear wall, form the acting shear forces along the old-to-new concrete interfaces.

These shear forces, should be, at all interface areas, smaller than the shear resistance that is mobilized by the relative slip that is consistent to the target performance level.

To determine the total resistance at the interfaces, the friction resistance at the compression zone is taken into consideration. This friction resistance is caused by external compressive stresses or compressive stresses that are activated by transverse bars/clamps, solidly anchored at both sides. The dowel resistance along the entire interface that is attributed to the same clamps or by anchored bolts shall also be taken into account in the determination of the total resistance at the interfaces, provided that its interaction with the friction resistance is also considered (see § 6.1.2). For tolerable slips, see S8.1.2.3 (a).

8.5 FRAME ENCASEMENT

8.5.1 Generalities

The walls can be (a) simple fill material (concrete or masonry) without any special connection to the fill-panel interface or (b) made by casted or grouted reinforced concrete that is adequately connected to the surrounding panel, thus transforming it into a shear wall or (c) made by strengthening of existing infill panels.

It is recommended to apply this method in a uniform vertical line of frame panels, along the entire height of the vertical line. In case the panel to be infilled was lacking masonry infill, the implications around the panel are verified in detail, along its height and width.

The axial force of the resulting shear wall includes the additional self weight and the axial forces that develop after the intervention and is in general relatively small. It is therefore anticipated that the rotation of the foundation will be significant while the effective stiffness of the shear wall will be reduced. In case that shear walls of reliable strength exist at the basement level, the potential of their encasement to the foundation of the shear wall is investigated (commonly in conjunction with their simultaneous strengthening). Thus, the rotation of the wall foundation is reduced and its effective stiffness increases.

This method consists of fill of selected frame panels either with shear walls or with steel braces in order to significantly increase the stiffness and seismic resistance of the structure. This technique also includes the strengthening of existing infill walls.

The new members are properly connected to the existing structure and are safely founded.

- b) In all cases, the implications of the new action effects induced are verified
 - i) for the entire set of the connected structural members and
 - ii) on the settlements and foundation members of the existing building
- c) During the analysis of the new structural system that is formed after encasement, the foundation rotation of the new shear wall shall be taken into account (under significantly eccentric compression).

8.5.2 Addition of simple “fillings”

The addition of a "simple filling" refers to the case where no special measures are taken for connecting the filling with the panel (e.g. no anchoring reinforcement or dowels are provided in the contact perimeter of the filling to the surrounding panel). In any case, no special measures are required on the vertical contact surfaces between the shear wall and the columns. It is also possible that there will be no contact with the columns and thus, a relevant sufficient void will be created. In case of concrete filling, it is recommended to use dowels-anchors at the horizontal upper and bottom contact surfaces between the shear wall and the panel.

In any case, the following apply:

- The additional shear forces developed in the beams and columns of the existing structural system, as the latter deforms during the design earthquake, shall be verified.
- Appropriate measures shall be taken in order to ensure the function that the friction mechanism will be activated at the upper and bottom contact surfaces between the filling and the panel.

It is recommended to perform calculations by assuming a local behavior factor $m \leq 1,5$.

To this end, the panel is horizontally extended in order to encase the two columns in the form of closed jackets within which the following are placed (i) the continuous vertical reinforcement provided against flexure of the entire multi-storey shear wall, as well as (ii) the required confinement for ensuring the target level of

- a) The fillings can be either unreinforced or reinforced concrete walls (constructed in-situ or precast), or made of masonry (reinforced or unreinforced), and are used for filling the selected infill panels, not necessarily along a unique vertical line.
- b) To assess the behavior of the fillings and their contribution to the total resistance of the structure, it is permitted to include them in the numerically model, as in § 7.4.1.
- c) A "filled" multi-storey frame that belongs in this category exhibits low ductility since it behaves as a high-rise shear cantilever.

8.5.3 Conversion of frames to shear walls

Conversion of frames into (reinforced concrete) shear walls requires the reliable connection of the encased wall within the surrounding panel in order to ensure the flexural

ductility (Figure C8.5). As an exception, in case that it is impossible to apply close jackets (e.g., at the contact limits with a neighboring property), the extension of the panel may only cover the three faces of the column provided that appropriate construction measures (e.g. welding of longitudinal bars, use of face-to-face dowels) ensure the adequate connection between the panel and the column.

It is recalled that the entire shear wall is subjected to the axial force of its self weight and the axial forces that will act after the encasement (additional loads and seismic loads).

In the absence of other criteria, the structural regularity criterion of § 5.5.1.2.(c) can be used. In other words, at the location that the shear wall does not extend further, the building shall not include any storey whose average failure index $\bar{\lambda}$ exceeds 150% of the average failure index of a nearby storey.

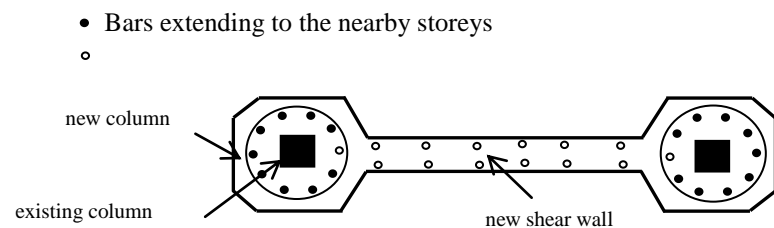

Figure C8. 7: Indicative encasement with thickness equal or smaller to the width of the beam

continuity along the height of the newly created multi-storey shear wall.

It is recommended that the new shear wall is constructed throughout the entire height of the structure. When its continuity is interrupted at a higher storey, it is required to verify the uniform distribution of the capacity-to-demand ratio, in order to avoid the development of a soft storey.

8.5.3.1 Encasement of thickness smaller or equal to the width of the beam

a) The shear force acting to the panel may be calculated as:

$$F_s = V_s - \frac{2V_{Rc}}{\gamma_{sd}} \quad (8.27)$$

where

V_s is the total shear force of the encased frame (new shear wall that is formed after the encasement)

V_{Rc} is the shear resistance of each column that is formed at the edges of the new shear wall (with their jackets included)

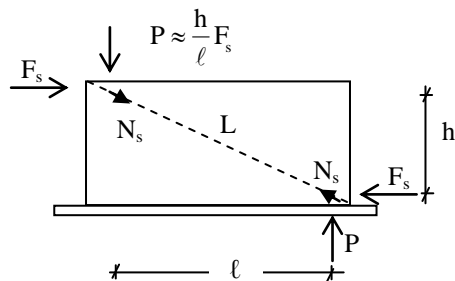

Figure C8.8: Panel shear force

If a more rigorous analysis is not conducted, it is permitted to perform the following approximate verification check (Fig. C8.8).

(i) It is assumed that a part of the panel F_s and of the vertical forces P , equal to $N_s = \frac{L}{\ell} F_s$, is resisted by the diagonal strut,

whose compression strength is estimated from the relationship:

$$N_R = \lambda f'_c t_w b_w, \quad (C8.15)$$

where:

N_R = is the residual resistance of the diagonal strut, beyond its critical deformation $\epsilon_{co} = 2 \times 10^{-3}$,

L, ℓ = is the length of the diagonal and the horizontal length of the panel, respectively,

$f'_c = 0,6f_c$, is the compression strength of concrete under transverse tension,

$\gamma_{sd} = 1,3$ uncertainty factor related to the numerical modeling of the action.

Moreover, due to the earthquake-induced frame deformation, vertical forces P are applied at the panel edges and in conjunction with the shear force F_s they induce compression of the diagonal strut.

- b)** The resistance of the panel is verified
- i) In terms of compression of the diagonal concrete strut.

t_w = the thickness of the panel,

b_w = the effective width of the diagonal strut which is taken according to § 7.4.(ζ,2),

λ = is the coefficient of the residual response of the diagonal strut beyond exceedance of its critical deformation. It can be taken equal to $\lambda = 0,4$.

(ii) The remaining shear stress $(F_s - \frac{\ell}{L} N_R)$ is undertaken by dowels arranged along the panel perimeter

$$F_{\beta\lambda, \text{οριζ.}} = F_s - \frac{\ell}{L} N_R \quad (\text{C8.16})$$

$$F_{\beta\lambda, \text{κατ.}} = \frac{h}{\ell} F_{\beta\lambda, \text{οριζ.}} \quad (\text{C8.17})$$

Verification:

$$F_{\beta\lambda, \text{οριζ.}} \not\geq \frac{1}{2} n_\delta F_{ud}$$

$$F_{\beta\lambda, \text{κατ.}} \not\geq \frac{1}{2} n_v F_{ud}$$

where:

n_δ, n_v = is the number of dowels along the length of the beam and along the length of each column respectively.

F_{ud} = is the dowel strength, considering the influence of cyclic loading and calculated on the basis of the strength of the weakest concrete between the frame and the panel (§ 6.1.2.2).

Besides, a minimum amount of dowels is arranged along the perimeter according to § 8.2.1.3(β)(v) and in any case not less than 3 #16mm bars per perimeter meter.

i) In terms of shear along the interface of the panel and the column.

iii) The design of the web and the edge

areas of the new shear wall is performed according to the provisions of EC2 and EC8. The horizontal reinforcement of the web is anchored within the closed jackets of the two columns while the vertical reinforcement of the web is anchored to the upper and bottom beam of the panel.

8.5.3.2 *Encasements with thickness greater than the width of the beam*

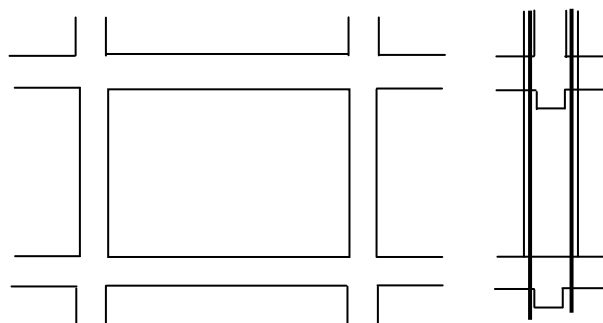

- Rebars continuing to the nearby storeys
- Rebars anchored within the beams

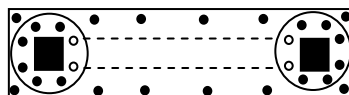

- a) The shear wall thickness is selected greater than the width of the beam of the encased frame in order to:
 - enable the continuity of the vertical reinforcement of the wall web through the frames
 - enable the arrangement of the connecting dowels along the horizontal direction, perpendicularly to the vertical faces of the beams.
- b) The verification of the panel resistance and encasement is made in accordance to §

Figure C8.9: Indicative encasement with thickness greater than the beam width

The vertical shear force at the column-jacket interface, V may be approximately taken as:

$$F_{\delta_{\text{επ.}}} \cong \frac{A_{c,\text{υπ.}} f_{c,\text{υπ.}}}{A_{c,x} f_{c,\mu\alpha\nu\delta.}} \left(\frac{M'}{z} + \frac{N'}{2} \right) \quad (\text{C8.18})$$

where:

$A_{c,\text{υπ.}}$, $f_{c,\text{υπ.}}$ = is the cross sectional area and the compressive concrete strength of the (initial) column

$A_{c,x}$, $f_{c,\mu\alpha\nu\delta.}$ = is the area in compression and the compressive concrete strength of the jacket

M' , N' = is the bending moment and the axial force that is applied on the shear wall after the intervention

z = is the flexural lever arm of the shear wall cross section in the direction of its length.

- (i) In case of shear wall that fall in the category described in § 8.5.3.1, it is only the new composite columns at their edge that contribute to the ductility of the new member.
- (ii) In case of shear wall that fall in the category described in § 8.5.3.2, the local ductility may reach 50% of the values that apply for monolithic shear walls designed to EC8.

In any case, the increased resistance and overstrength of the new shear walls is taken into account in conjunction with the ability to

8.5.3.1.

8.5.3.3 *The surrounded columns at both sides of the frame*

The jacketed columns of the frame are considered to fully contribute in undertaking the new (after the intervention) internal forces of the resulting shear wall. To this end, the interface between each column and its jacket is checked and (if required) it is appropriately reinforced.

8.5.3.4 *Ductility*

The available ductility of the new shear wall depends on the extent to which the EC8 provisions (§ 5.4.3.4) related to monolithic earthquake-resistant shear walls were taken into account.

raise any existing irregularity of the structure.

It is recommended that the thickness of the jacket at each side is not less than 50 mm, so as to be feasible to the arrange hooks on the web reinforcement added.

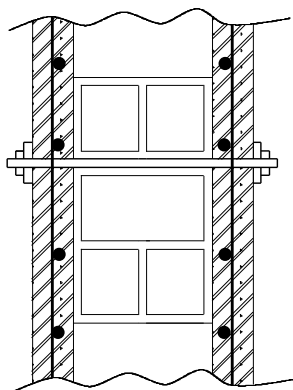

Fig. C8.10: Indicative cross section of the application of strengthening of an existing masonry infill.

In each concrete-to-masonry interface the sum of the friction and dowel resistance (inclusive of all connection links) shall be equal to $V/2$. The design of these connection links is performed

8.5.4 Strengthening of the existing masonry infill

- a) It is possible to strengthen an existing masonry infill of a frame through the application of a two-sided jacket of gunite. Within this jacket, horizontal and vertical reinforcement (of equal reinforcement ratios, $\rho_v = \rho_h$), is provided, under the condition that the jacket is solidly connected to the masonry through face-to-face bolted links ending to anchor plates.

- b) The connection links shall undertake the entire amount of shear force V that will be transferred to the strengthened masonry infill.

according to the provisions of § 6.1.3 for cyclic loading.

It is not, in general, possible to extend the reinforcement in such a way that they can tie the edge columns and the (upper and bottom) beams. Besides, anchorage of the horizontal reinforcement on the faces of the columns (and inevitably near their edges) is not recommended anyway. On the other hand, neither the anchorage of the vertical reinforcement on the beam or the slab is always feasible. It is easier, though less efficient, to anchor the ends of the rebars on the masonry itself using hooks that hold the rebars aligned across the other direction. In Figure C8.10 the anchorage of a horizontal reinforcing bar is indicatively illustrated.

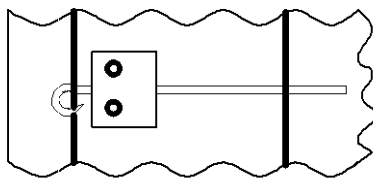

Figure C8.10: Indicative illustration of anchorage of horizontal reinforcement

It is permitted to use the following expressions:

(i) Cracking shear of the web:

- c) The design shear resistance of the strengthened masonry may be added to the shear resistance of the frame columns.
- d) The jacket reinforcement cannot be less than $\min \rho_h = \min \rho_v = 0,5 \times 10^{-3}$ normalized to the initial thickness of the wall
- e) The additional strengthening reinforcement shall be anchored in the best possible way, depending on which their maximum stress developed shall be estimated.

f) The shear resistance of the web shall be calculated based on reliable data from the literature.

$$V_{cr} = \frac{1}{\sqrt{\alpha_s}} (0,6f_{wtd} + 0,4\sigma_o) \ell_w t_w \quad (C8.19)$$

(ii) Shear source of the scattered shear failure in the web:

$$V_{R3} = \left[\frac{0,3}{\sqrt{\alpha_s}} (f_{wtd} + \sigma_o) + \lambda f_{syd} \right] \ell_w t_w \not\geq 0,7V_{R2} \quad (C8.20)$$

where:

$$\alpha_s = h_w : \ell_w$$

f_{wtd} = design tensile strength of the masonry (can be taken equal to 1/15 of the compressive strength)

$$\sigma_o = N : t_w \ell_w \text{ (practically zero)}$$

ℓ_w, h_w, t_w = length, height and thickness of the masonry

$$\rho = \rho_v = \rho_h \text{ ποσοστό οπλισμού κορμού}$$

f_{syd} = design yield strength of the reinforcement

$\lambda = \sigma_s : f_{syd}$, coefficient of the mobilized reinforcement stress (depending on the efficiency of the reinforcement anchorage) which can be approximately estimates as follows:

$$\lambda = 1 - \frac{0,6 f_{syd} d_s}{k_b f_{mtd} \ell}$$

where:

$$\ell = \min \{ \ell_w, h_w \}$$

d_s = diameter of the rebars

f_{mtd} = design tensile strength of the jacket concrete

$k_b = 1$, without any additional care regarding the anchorage of the

reinforcement

2, in case of “nailing” on the masonry

3, in case of “nailing” on the perimeter frame members (not recommended)

V_{R2} , as in the following paragraph

(iii) Shear force of the diagonal compression failure of the web

$$V_{R2} = 0,1L_w (t_{w,0} f_{wcd,0} + 2t_m f_{mcd}) \quad (C8.21)$$

where:

$f_{wcd,0}$ = design compression strength of masonry

$f_{mcd,0}$ = design compression strength if the jacket concrete

$2t_m$ = total thickness of the jacket

L_w = the length of the diagonal of the masonry infill

$t_{w,0}$ and $f_{wcd,0}$ the thickness and the compression strength of the initial masonry

When more accurate data are not available, diagrams similar to those referred to in § C.7.4.1 (g) for unreinforced masonry can be used for the case of a shear panel, assuming that $\gamma_y = 1.5 \text{ ‰}$,

$\gamma_u = 6 \text{ ‰}$ and the shear strength \bar{f}_{wv} that corresponds to the ultimate shear resistance of the masonry is equal to $0.85 V_{R3}$.

For the case the numerical modeling is performed using diagonal struts it can be assumed that:

$$\varepsilon_y = 0.0015 \frac{h_w}{\ell_w} \text{ και } \varepsilon_u = 0.006 \frac{h_w}{\ell_w}$$

and compressive strength $\bar{f}_{wc,s}$ that corresponds to $0.85 V_{R2}$

The shear resistance to diagonal compressive failure of the web must be reliably greater than the shear force that induces scatter shear failure in the web, in order to ensure the transfer of the shear force from the frame to the strengthened masonry through the diagonal strut, without the risk of brittle failure of this strut.

g) For the simulation of the behavior of the strengthened masonry appropriate diagrams are used i.e. either in the form of shear stress-angular strain diagrams (when the masonry is modeled as a panel) or compressive stress-strain relationships (when the masonry is modeled using diagonal struts), in accordance to the relevant provisions of § 7.4.1 regarding the unreinforced masonry.

Roughly, masonry infills that are strengthened according to the provisions of the present Chapter, are deemed able to exhibit a displacement ductility factor equal to 2.

Flexible plastic or stainless steel mesh can be used within the plaster, properly "nailed" on the jackets of the masonry and on the surrounding frame (columns and upper beam) and extending at least 30 cm on either side of the perimeter contact. The wall strengthened as above can be deemed in general able to resist the out-of-plane actions.

For steel truss systems a reduced critical damping correction factor is taken into account according to EC 8-1 § 3.2.2.2 (1) and (3) for a viscous damping ratio $\zeta = 4\%$ or 2%.

The level of bracing truss shall be located, to the greatest possible extent, without eccentricity with respect to the plane that is defined by the axes of the columns of the surrounding frame. If the bracing is installed with eccentricity and exceeds the 1/3 of the smallest width of the surrounding column, this eccentricity shall be appropriately taken into account in the analysis.

The braces can be added to one or more storeys which have significantly inferior strength or stiffness than the other (i.e., soft storeys, building with pilotis, etc.)

When there is no substantial problem in particular storeys and the entire structural system needs to be strengthened, the ideal arrangement of the braces is along a single vertical line of frame panels, particularly in the perimeter, and up to the entire height of

- h) The ductility of the strengthened masonry infills may be estimated based on reliable data from the literature.
- i) The strengthened wall shall be able to undertake the out-of-the-plane actions that are due to the wind (in case of external walls) or due to the earthquake (in all cases).

8.5.5 Addition of bracings, conversion of the frames to vertical trusses

8.5.5.1 Introduction –Types of braces

- a) The braces are typically arranged so that they form, together with the vertical and the horizontal members of the frame, a composite structural system consisting of the frame and truss.

the structure.

The common and most appropriate bracing methods are steel braces along a single or both the diagonals of a panel (simple diagonal or cross-diagonal X). It is possible to arrange the braces in shapes V or Λ, wherein their diagonal members end up in joints, while their top edge is connected ("with eccentricity") at an intermediate point of the horizontal frame members. The use of K-bracing, with an intermediate connection on the columns, is generally prohibited during interventions in existing buildings.

For the connection of the diagonal braces with the frame members, and also for strengthening the latter, it is recommended to additionally arrange steel members along the perimeter of each braced panel (creation of a closed, encased frame). These perimetric elements, in a horizontal and/or vertical layout are connected to the beams and columns, respectively, of the frame, either continuously or intermittently, so that they can jointly contribute to the resistance of the seismic action. The composite members that are formed develop combined axial and flexural stresses, even when the diagonal braces of the panel developed exclusively axial tension.

Linear reinforced concrete elements can also be used as braces. This Standard does not cover this case.

Seismic action mainly induces axial forces to the members of this truss. The energy dissipation takes place in those members where the seismic action induces (almost exclusively) axial tensile stresses.

For the addition of new side trusses, with eccentricity with respect to the frame, see § 8.6.

- b) It is possible to add trusses that of normal or inverted Y shape, where the inclined elements end up and connect on to beam-column joints, and the vertical element is connected to an intermediate point of the beam, particularly on an projecting vertical element of small size ("seismic

link”): The energy dissipation takes place exactly at this vertical element, under flexural or shear stress, or a combination of the two.

8.5.5.2 Structural details of the braces

The design and structural configuration of the strengthening braces shall aim to the control of their post-buckling behavior and its subsequent unfavorable (distortion and local buckling of the components of the link, weld fracture, failure of dowels/anchors etc.) which is likely to prevent the development of their full tensile strength during the next semicircle of the response.

If the analysis and the verification have not been performed using a uniform q the values of the relevant Table 1 can be used for $2 \leq q \leq 4$.

- a) It must be ensured that the premature brittle failure of the diagonal braces and their connections after potential premature buckling of these elements will be avoided.
- b) In order to prevent local buckling, the cross sections of the braces that may be subjected to compression stresses shall meet (for the case of steel elements) the width-to-thickness ratio limits prescribed in EC 3-1-1, § 5.5 and in Table 6.3 of EC 8-1, depending on the value of the total behavior factor q that characterizes the behavior of the strengthened structure at the target performance level for which the particular structure is verified.
- c) In order to avoid concentration of inelastic strain at the locations of screw holes, the net section of the braces under tension shall satisfy the

requirements of § 6.2.3(2), (3) and (4) of EC 3-1-1.

The connections between the braces shall comply with the requirements of § 6.5.5 of EC8-1, in order to avoid premature failure.

8.5.5.3 *Bracing types*

Regarding the distinction of the bracing types see EC 8-1, § 6.7 (braces without eccentricity) and § 6.8 (braces with eccentricity).

In bracing systems the “coupling beam” (i.e., the part of the beam which acts as an eccentric coupling) is particularly stressed in flexure and shear thus requiring special internal joints that can maximize the ductility of the area.

There are two types of bracings: a) those without eccentricity and b) those with eccentricity.

Braces with eccentricity are considered those cases where the connection of at least one brace edge is eccentrically made with respect to the nearby column-beam joint or another brace-beam joint.

8.5.5.4 *Design of braces without eccentricity*

The combination of vertical actions will be resisted exclusively by the system of the vertical and horizontal members of structure, possibly taking into account the composite function of the existing members with the steel elements that are added to the perimeter of the panels to complement the bracing. In the combination of vertical actions, V or Λ shape bracings are not considered to provide intermediate support to the horizontal member to which they are connected to.

The adverse effect, however, of this intermediate support is taken into account as in the following paragraphs d (iii) and e (iii).

In diagonal X-braces, it is recommended that the normalized

a) The diagonal braces shall not be taken into account in the verification of the structural resistance against vertical loads.

b) The diagonal braces shall comply with the requirements

slenderness, as defined in § 6.7.3 (1) of EC8-1, shall not exceed the value of 2.0 neither be less than 1.3.

Since the compression struts of X-braces are neglected against seismic action, the lower bound imposed with respect to their normalized slenderness aims to limit the force that they will develop prior to buckling and to reduce the overstress of the horizontal and vertical members of (strengthened) structure that with significantly greater stresses than those resulting from the analysis.

The buckling length of the X-bracing diagonal struts that are connected with a common steel laminate in the middle of their length, is recommended to be taken equal to half of the diagonal length (inclusive of any steel laminates at their ends), due to the restraint provided by the opposite diagonal in tension.

In other types of bracing, the buckling length of the diagonal braces that are welded to steel laminates is recommended to be taken equal to the total diagonal length for out-of-plane buckling, or 80% of this length for in-plane buckling. For bolted connections, the in-plane buckling length is recommended to be taken equal to 90% of the total diagonal length.

Under certain conditions and in any case after reduction of the q values, additional structural members can be considered as primary either in their present condition or after appropriate interventions.

of § 6.7.3 of EC8-1, regarding member slenderness.

c) The buckling length of the diagonal braces shall be estimated conservatively, taking into account the connection type between these elements and the other structural members.

d) Force-based design of the bracing:

i) The results of the elastic analysis on the basis of an elastic spectrum that is divided by a uniform behavior factor q for the strengthened structure shall be taken into account.

For “Life Safety” and “Collapse Prevention” performance levels, only the braces shall be, in principle, considered as primary. Moreover, primary shall be also considered

those vertical and horizontal members of the existing structure at the perimeter of the panels where the bracing is constructed, taking into account their composite function with the steel elements that are connected to them.

- ii) Provided that the relevant provisions of the following paragraph (iii) and § 4.6.3, are satisfied, the following values of the behavior factor q can be used, depending on the performance level adopted
- For “Life Safety” performance level:
 - For simple diagonal braces and cross-diagonal X-bracings , $q=3.5$
 - For V or Λ -shape bracings, $q=2.0$, provided that the section used fall in category 1 or 2, according to Table 5.2 of EC3-1-1, or $q=1,5$ if class 3 sections are used.
 - For “Collapse Prevention” performance level the above values can be increased by 35%.
 - For “Immediate Occupancy after the earthquake” performance level, § 9.2 applies, which is equivalent to $q=1$ and implies consideration of all the structural members of the strengthened structure in the finite element model developed.

iii) In order to use the above high values of q , the following additional provisions apply:

It is recommended to limit the difference between of the total horizontal projection of the cross-sectional area of tension diagonals for the two directions of seismic action, to 10% of the mean of these values.

If overstrength is defined as the ratio of the strength of a brace in tension over the corresponding stress that results from elastic analysis, then it is recommended that the maximum value of this overstrength for the entire structure shall not exceed 1.25 times the minimum value of overstrength within this structure.

To ensure adequate overstrength, it is recommended to design the horizontal and vertical members of the perimeter of the panels (where the braces are arranged), which are considered as “primary”, for the combination of bending moments from the analysis, and also for the axial force that is equal to the sum of : a) the axial force due to the vertical load, and b) the axial force due to seismic action, multiplied by 1.25 of the minimum value of overstrength (as defined above). This applies to all diagonal members in tension of the strengthened structure (for both positive and negative direction of seismic action, whichever is critical).

- The layout and cross section of the diagonal braces shall be practically symmetric for the two directions of seismic action, in the plane of the frame.
- A smooth distribution of the bracings overstrength shall be ensured in plan and along the height of the structure.
- The vertical and horizontal members of the strengthened structure that are considered as “primary” shall have sufficient overstrength to ensure that energy consumption will be limited to the diagonal braces.

For yield force of the members in compression equal to 20% of the buckling load, the reported values of the ultimate strain correspond to values of the displacement ductility factor between 40 and 50. However, the absolute magnitude of these ultimate strains is in fact smaller than the corresponding strain developed in the members in tension.

The value of 10 used as a multiple of δ_u for the estimation of the ultimate strain of the members in compression is valid for tubular or hollow sections belonging to Class 1 as defined in Table 5.2 of EC 3-1-1. For sections of the same class, but of different shape (I-shape, double angle, or two welded U sections), the value 9 applies. The value 8 applies to all other section classes and cross section types.

- The vertical members at the edges of the bracing that have only one diagonal brace (i.e. X-bracing) shall be designed for the potential development of the total buckling load of this diagonal.

e) Deformation-based design of the bracing

- i) The results of a pushover analysis are taken into account using a model that includes all the members of the strengthened structure.
- ii) In the framework of pushover analysis, the braces shall be modeled as elastoplastic elements. The following shall be taken into account:

Resistance values (yielding force) F_y :

- In elements in tension: the actual yielding force
- In elements in compression: 20% of their buckling load

Ultimate strain values:

- In elements in tension: their yield strain multiplied by 12, and
- In elements in compression: 8 to 10 times their buckling deformation

Beyond the ultimate strain, the resistance is diminished.

- iii) Horizontal members connected with V or Λ - bracings must be designed considering that a

shear force is applied at the connection join. This force is equal to the difference between the strength of the brace in tension and the 30% of the buckling load of the brace in compression.

8.5.5.5 Design of braces with eccentricity

- a) As is the case of braces without eccentricity, the diagonal braces shall not be considered to contribute to the resistance of the structure against vertical actions.
- b) Regarding the “seismic link” (§8.5.5.1.b) the definitions and requirements of § 6.8.2 of EC 8-1 shall be applied.
- c) Regarding the design of strengthening using braces with eccentricity, both the means already described for the case of braces without eccentricity can be applied.

Specifically:

- i) Force-based design shall be performed on the basis of elastic analysis results that correspond to the elastic spectrum divided by a uniform behavior factor q for the strengthened structure.

For the case of performance levels “Life Safety” and “Collapse Prevention”, it is only the braces that are considered as “primary”

Provided that the relevant conditions regarding the application of elastic analysis prescribed in Chapter 5 are met.

members. The vertical and horizontal members of the existing structure that are arranged in the perimeter of the panels (where the braces are arranged) shall also be considered as primary, taking into consideration their composite function with the steel elements that are connected to them. The following values for the uniform behavior factor q can be adopted, provided that: a) the provisions of § 6.8.2 EC8-1 shall be applied for the “seismic link” and b) that the design of the other bracing elements, will be made on the basis of the demand that results from the elastic analysis under seismic action after multiplication with an appropriate capacity design coefficient.

This coefficient may be taken equal to 18-times the minimum value of the “available capacity” over the “effective axial force demand” as it results from the seismic analysis. The minimum value of this ratio is used among those corresponding to all the seismic links of the strengthened structure.

Under these conditions, the following values of “ q ” can be used:

- Performance level “Life Safety”: $q=5,0$
- Performance level “Collapse Prevention”: $q=7,0$
- Performance level “Immediate Occupancy”: § 9.2 applies

- ii) Alternatively, the design can be made in terms of deformations, based on the results of pushover analysis, and after numerical modeling of all the elements of the strengthened structure.

In the framework of pushover analysis the braces shall be modeled as elastoplastic.

Regarding the yield force and the ultimate strain of the elastoplastic diagram to be used for the braces in tension and compression, the provisions of § 8.5.4.3e apply.

As for the “seismic link”, the yield force shall be taken equal to its shear strength, as it is dominated by bending or shear according to §6.8.2 EC 8-1. The ultimate strain δ_u is determined through an ultimate rotation taken equal to 0,12rad in case of bending-dominated failure or 0,03rad if the failure is dominated by shear.

8.5.5.6 *Verification of the structural members of the R/C frame*

Critical structural members are commonly considered those belonging to the frame encasing the panel, and more often, the joints of vertical and horizontal members.

The structural members of the initial (prior to strengthening) structural system shall be able to resist the potentially increased (after the intervention) internal forces. Otherwise, their strengthening is required.

8.6 CONSTRUCTION OF NEW LATERAL SHEAR WALLS

8.6.1 Introduction

Common location of those shear walls or bracings is the perimeter or the external corners of the structure, which are favorable for shear walls of Γ-shape. The addition of shear walls in the structure's interior is preferable and easier to be performed through their encasement within the frames of the structure (see § 8.5).

- a) It is possible to add (apart from the existing structural system) new reinforced concrete shear walls in order to resist partially or fully the seismic action. Steel bracings can also be added if appropriately connected to the existing structure and safely founded.
- b) The provisions of § 8.5.1.(b) and (c) also apply here as well.
- c) In case of application of new lateral bracings, the provisions of § 8.5.5 apply.

8.6.2 Links

- a) The transfer of seismic forces from the existing structure to the additional shear walls shall be performed through appropriate connecting arrangements (i.e., “links”) that shall be provided at the level of all slab diaphragms, along the beams or in the vicinity of the location of the columns of the structure.
- b) The regions within which the links are anchored (on the initial structure and on the new shear walls) shall ensure the transfer of seismic forces.

The design of the links for shear and tension is performed according to the provisions of Chapter 6, whereas for the case of compressive force restoration on the arm of a corner shear wall, an appropriate “buffer” is provided, that is able to transfer the pounding-induced compression stresses without essential damage.

The commentary of § 8.5.1 (c) apply.

Also see Chapter 4

- γ) All the links shall behave quasi-elastically during the design earthquake. To this end, they are designed for appropriate overstrength.
- d) The transfer of seismic forces from the existing structure to the lateral shear walls can be performed through appropriate links which shall function:
 - in shear (in the general case) or
 - axially, i.e., in compression or tension in the special case that Γ-shape shear walls are added at the corners of the building.

8.6.3 Foundation of new shear walls

- a) It is recommended to engage the foundation of the new shear walls with the existing foundation.
- b) It is recommended, to the greatest possible extent, increase the axial force that the new shear walls will bear under the design earthquake.
- c) The provisions of § 8.5.1 (c) apply.

8.6.4 Diaphragms

The diaphragm action of all slabs of the existing structure is verified together with the redistribution of actions due to the relocation of the supports on the new shear walls, while strengthening measures of the diaphragm are also taken if needed.

8.7 INTERVENTIONS ON FOUNDATION ELEMENTS

The inadequacy of the foundation elements may refer to either to the foundation itself (i.e., in terms of its height) or its reinforcement. The above inadequacy can be addressed by increasing the dimensions of the foundation. In this case, this increase in dimensions is combined with the technique of strengthening of the superstructure with the addition of vertical members (provided that such strengthening is anyway foreseen).

In calculating the characteristics of the strengthened members, and when reliable methods for estimating the relative slip at the interfaces of new and existing members are not available, it is provisionally permitted to use the approximate procedure of considering appropriate coefficients of monolithic connections that are justified in the literature. The verification of these interfaces follows the procedure described in § 8.1.

When more accurate data are not available, it is permitted to take:

$$k_k = 0,70$$

$$k_r = 0,90$$

$$k_{\theta y} = 1,30$$

$$k_{\theta u} = 0,80$$

CHAPTER 9

SAFETY VERIFICATIONS

9.1 SCOPE

See Chapter 4, Paragraph 4.4 for the rationale of the verifications.

9.1.1 The present chapter includes the criteria for the verification of the safety inequality during the assessment or redesign, in terms of forces or deformations:

- Depending on the analysis method used;
- Depending on the expected failure mode (brittle or ductile).

9.1.2 These criteria are presented separately for each performance level.

9.1.3 a) When the assessment aims to lead to a confirmation of the target capacity, all structural elements must meet the verification criteria.

b) If the assessment aims to aid decision making on whether or not to redesign, all structural elements must meet the verification criteria after the redesign.

c) For buildings where the influence of higher modes is important, static inelastic analysis may be applied in combination with dynamic elastic analysis, see §5.7.2.b, so all verifications using both methods are made, while allowing an increase of the values of the parameters involved in the verification criteria by 25%.

See related § 5.4.3.

See also § 5.4.3 on primary/secondary elements.

Thus, if the method of the uniform behavior factor is applied, q values may be increased by 25%, while if the method of partial factors (for individual structural elements) is applied, m values may be increased by 25%.

For performance level “Immediate use after the earthquake”, the structure (and its infills) is expected to exhibit quasi-elastic behavior and not develop post-elastic deformations. Thus, in general $q \approx m \approx 1.0$ ($\div 1.5$).

For γ_{Rd} factors: $\gamma_{Rd} = 1$.

The two methods of verification (in terms of deformations or internal forces) are equivalent and should lead to the same results since elastic behaviour is required.

$\gamma_{Rd} = 1$ in this case also.

9.2 FOR PERFORMANCE LEVEL “Immediate use after the earthquake”

9.2.1 For this performance level, the general safety inequality (see Chapter 4) is checked for primary and secondary elements (and masonry walls) in terms of internal forces with:

- S_d : value of the internal force component from (elastic) analysis, with γ_{Sd} according to § 4.5.1
- R_d : design value of the resistance in terms of internal forces, as defined in Chapters 7 and 8 calculated with mean values of material properties, according to § 4.5.3.

9.2.2 Alternatively, in case of inelastic analysis and ductile failure modes, the verification of the safety inequality may be done in terms of deformations, with:

- S_d : the deformation measure from inelastic analysis with γ_{Sd} according to § 4.5.1,
- R_d : the value of this deformation measure at yield, δ_y (i.e. chord rotation at yield, θ_y , angular deformation of wall panel, γ_y), calculated without material safety factors using mean values of material properties,

as set out in § 4.5.3 and Chapters 7 and 8.

9.2.3 Non-structural elements other than infill walls must satisfy the safety verifications for appendages of § 4.3.5 of EN 1998-1:2004.

**9.3 FOR PERFORMANCE LEVELS
“Life protection” or “Collapse prevention”**

For infill walls, see the extensive related references in Chapters 4, 7 and 8.

In performance level “Life Protection” all elements of the structure may develop significant inelastic deformations, but primary elements must have a substantial safety margin against exhaustion of their available deformation capacity.

In performance level “Collapse prevention” the available deformation capacity of all primary and potential secondary vertical elements of the structure may not be exceeded, while for horizontal secondary elements this is generally permitted.

9.3.1 Inelastic analysis

In case of inelastic analysis, the general safety inequality, see Chapter 4, is checked as follows (cf. §§ 4.4.3 and 5.1.3) :

- a) For ductile behavior and failure modes as well as for infills, the verification is done in terms of

deformations with:

- S_d = deformation measure δ (θ , γ etc.) from the analysis with γ_{Sd} according to § 4.5.1, and
- R_d = design value of the available deformation, not greater than the expected ultimate deformation δ_d (ultimate chord rotation θ_d , angular deformation of wall panel γ_d etc.).

R_d shall be calculated based on mean values of material properties and with an appropriate γ_{Rd} factor, as follows.

i) For performance level “Life protection” the following apply:

For primary elements, the value of R_d may be calculated as:

$$R_d = \delta_d = 0.5(\delta_y + \delta_u) / \gamma_{Rd} \quad (1a)$$

For secondary elements, the value of R_d may be taken equal to the value of δ at failure, δ_u , divided by γ_{Rd} :

$$R_d = \delta_d = \delta_u / \gamma_{Rd} \quad (1b)$$

For infills which are included in the model, the value of R_d may be taken equal to the value of δ at failure, δ_u , divided by γ_{Rd} :

$$R_d = \delta_d = \delta_u / \gamma_{Rd} \quad (2)$$

Verification of the horizontal secondary elements is not required.

The value of γ_{Rd} in Eq. (1a), (1b) and (2) should be such so that the value of R_d corresponds to mean value minus one standard deviation.

If chord rotation is used as δ of structural elements and its value at failure, θ_u , is calculated by Eq. (Σ.8a) of Chapter 7, a value of γ_{Rd} equal to $\gamma_{Rd}=1.5$ may be used. If the plastic part of the chord rotation is used as δ of structural elements and its value at failure, θ_u^{pl} , is calculated by Eq. (Σ.8b), a value $\gamma_{Rd}=1.8$ may be used. For infills, in terms of γ_u or ε_u , it is recommended to use $\gamma_{Rd}=1.3$ for unreinforced wall panels and $\gamma_{Rd}=1.2$ for reinforced ones.

Verification of the horizontal secondary elements is not required.

- (ii) For performance level “Collapse prevention” the value of R_d is taken equal to:

$$R_d = \delta_d = \delta_u / \gamma_{Rd}, \quad (3)$$

where deformation δ_u at failure is calculated based on mean values of material properties.

For primary elements the value of γ_{Rd} should be such so that the value of R_d corresponds to mean value minus one standard deviation.

The value of γ_{Rd} for primary elements may be the same as the one used for performance level “Life protection” (see commentary above)

For secondary elements, as well as for infills, factor γ_{Rd} is taken equal to $\gamma_{Rd} = 1$.

For γ_{Rd} factors: $\gamma_{Rd} = 1$.

- b) For brittle behaviour and failure modes, the general safety inequality is checked in terms of forces, with:
- $S_d =$ force measure from (inelastic)

analysis, with γ_{sd} according to § 4.5.1, and

- $R_d =$ design value of the resistance in terms of forces, calculated based on representative values of material properties and material safety factors γ_m according to § 4.5.3 and Chapters 7 and 8 for primary elements, or based on mean values of material properties without material safety factors γ_m for secondary elements.

9.3.2 Elastic analysis – Method of local ductility factors m

In the case of elastic analysis, the general safety inequality, see Chapter 4, is verified in terms of internal forces as follows:

- a) For ductile behaviour and failure modes, and for wall panels that are included in the model, the following inequality is evaluated:

$$S_d = S_G + S_E/m < R_d, \quad (4)$$

where

- S_G : force component due to gravity actions of the seismic combination
- S_E : force component due to the earthquake action from (elastic) analysis, with γ_{sd} according to § 4.5.1
- $m = \delta_d / \delta_y$ (5)

the local behaviour factor, where:

- δ_d the design deformation at failure according to Eq. (1)-(3) as appropriate, with γ_{Rd} values as set out in § 9.3.1(a),
 - δ_y is the deformation at yield which is used as R_d according to § 9.2.2 and § 9.3.1(a)
- R_d : design value of the resistance in terms of forces, calculated using mean values of material properties according to § 4.5.3 and Chapters 7 and 8.

For brittle behaviour and failure modes, the use local behaviour factor m is not employed.

b) For brittle behaviour and failure modes, the verification of the general safety inequality is done with:

R_d = design value of the resistance in terms of forces, calculated based on representative values of material properties and material safety factors γ_m according to § 4.5.3 and Chapters 7 and 8 for primary elements, or based on mean values of material properties without material safety factors γ_m for secondary elements.

S_d = force component that results from capacity design principles and member equilibrium, when ductile regions that affect the member develop their overstrength, $\gamma_{Rd}R_d$, with the values of γ_{Rd} set out below.

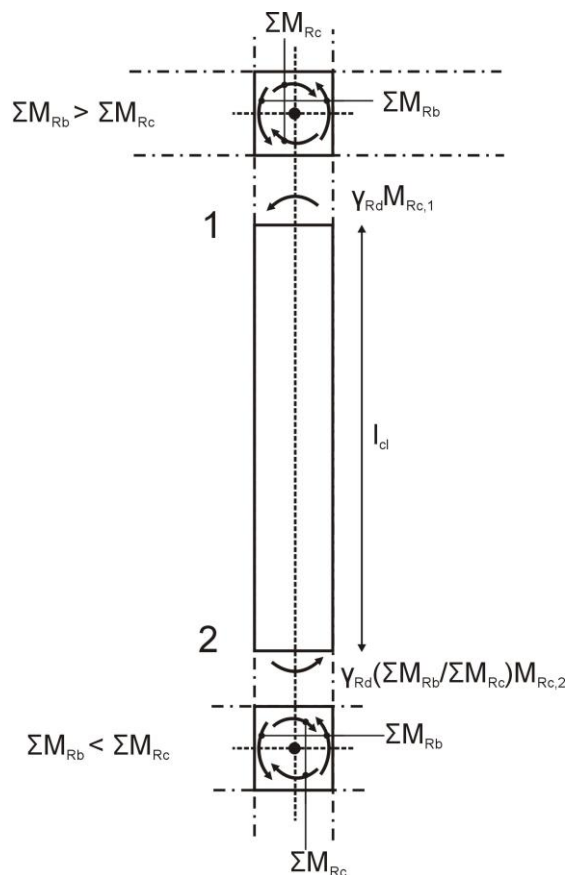

Fig. S.9.1 Typical example of bending resistances at the ends of columns for the calculation of capacity design shear force.

Specifically:

(i) For columns:

Design shear shall be calculated in two mutually orthogonal directions, and checked separately and independently (without interaction between the two directions). For rectangular, T- and L- shaped columns those directions are the principal axes of their cross sections.

The design value V_{sd} of the shear force shall be calculated assuming that moments M_{id} (where $i=1,2$ denoting the end sections of the element) act at the ends of the column, and correspond, for positive and negative directions of seismic loading, to the formation of plastic hinges at the ends of beams or columns (wherever they develop first) that frame into the joint to which the column's end i is connected. Moments M_{id} are calculated as follows:

$$M_{i,d} = \gamma_{Rd} M_{Rc,i} \min\left(1, \frac{\sum M_{Rb}}{\sum M_{Rc}}\right), \quad (6)$$

where

BODY

The value of the moment of resistance M_{Rc} of columns is calculated for a value of the axial force equal to the sum of:

- (i) the column axial force due to the seismic action which develops simultaneously with the moment $M=M_{Rc}$, assuming that the ratio of moment-axial force is equal to that resulting from elastic analysis for the seismic action, and
- (ii) the axial force caused by the non-seismic actions of the seismic combination.

$M_{Rc,i}$ = flexural resistance at column end i with its vector perpendicular to V_{Sd} for the sense of the seismic loading and bending moment considered (this also concerns the axial force of the column), calculated using mean values of material properties

$\Sigma M_{Rc}, \Sigma M_{Rb}$ = sum of projections (perpendicular to V_{Sd}) of flexural resistances of columns and beams which frame into the joint of end i , for the sense of the seismic loading and bending moment considered, calculated using mean values of material properties

γ_{Rd} = factor accounting for overstrength due to steel strain hardening and confinement of concrete, as well as the Data Reliability Level (DRL), with values as follows:

- for primary elements:
 - for “High” DRL: $\gamma_{Rd} = 1.25$,
 - for “Satisfactory” DRL: $\gamma_{Rd} = 1.40$,
 - for “Tolerable” DRL: $\gamma_{Rd} = 1.50$,
- for secondary elements $\gamma_{Rd} = 1.0$.

The value of $M_{i,d}$ at end i cannot be greater than the value at given end resulting from elastic analysis.

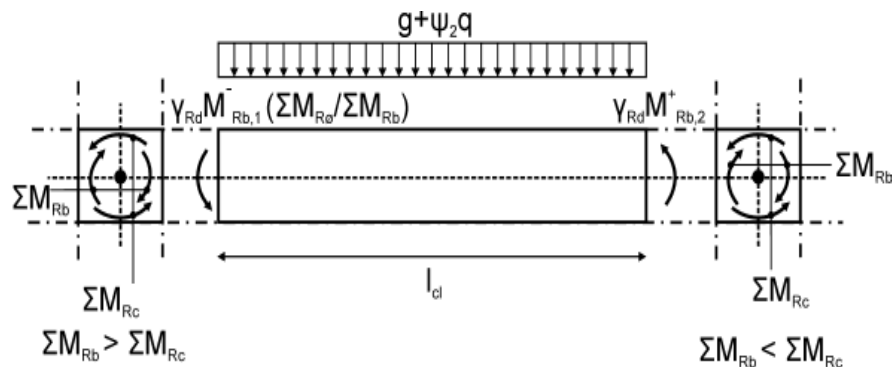

Fig. S.9.2 Typical example of flexural resistances at ends of beams for the calculation of capacity design shear force

(ii) For beams:

The design value of the shear force, V_{sd} , shall be calculated assuming that between the ends of the beam $i=1$ and $i=2$ act:

- the lateral loads which correspond to the seismic combination of actions according to § 4.4.1.2, and
- the moments M_{id} that correspond, for each of the two possible senses of the seismic action and seismic bending moment, to formation of plastic hinges in beams or columns – wherever they form first – which frame into the node to which the beam is connected at end i . Moments M_{id} are calculated as follows:

$$M_{i,d} = \gamma_{Rd} M_{Rb,i} \min\left(1, \frac{\sum M_{Rc}}{\sum M_{Rb}}\right) , \quad (7)$$

όπου: where:

$M_{Rb,i}$ = flexural resistance of beam end i , for the sense of the seismic action and seismic bending moment considered, calculated using mean values of material properties

$\sum M_{Rc}$, $\sum M_{Rb}$, γ_{Rd} = as defined in § 9.3.2, cl. (b)i above.

The value of $M_{i,d}$ at end i cannot be greater than the value at given end resulting from elastic analysis.

(iii) For shear walls:

The design value of the shear force, V_{sd} , shall be calculated as follows:

$$V_{Sd} = \frac{\gamma_{Rd} M_{Rw}}{M_{EW}} V_E , \quad (8)$$

όπου: where:

V_E = wall shear force from elastic analysis for the seismic action that corresponds to the performance level considered

M_{EW} = flexural moment at base of shear wall with vector perpendicular to those of V_E , V_{sd} , as resulting from the analysis for the seismic action that corresponds to the performance level considered

M_{RW} = flexural resistance at base of shear wall with vector perpendicular to those of V_E , V_{sd} , calculated using mean values of material properties and the value of the axial force which corresponds to the performance level considered

γ_{Rd} = overstrength factor as defined in § 9.3.2, cl. (b)i above.

In case of rectangular shear walls, only the shear force parallel to the longer side of the wall. In case of shear walls with complex cross-section that consists of more than one rectangular segment with sides at a ratio at least 4:1, the calculation will be done in two mutually orthogonal directions.

(iv) For foundations

The design value for any force component for the verification of foundation soil and the foundation elements shall be calculated as follows:

$$S_{Fd} = S_{F,G} + \gamma_{Rd} \Omega S_{F,E} , \quad (9)$$

where:

$S_{F,G}$: The design value of the force component from analysis for gravity loads (permanent and variable) which are part of the seismic combination of actions according to § 4.4.1.2

- $S_{F,E}$: The design value of the force component from elastic analysis for the seismic action that corresponds to the performance level considered
- γ_{Rd} : overstrength factor as defined in § 9.3.2, cl. (b)i above, and
- Ω : the minimum value of the ratios M_{Rd}/M_{Ed} along the two horizontal directions of the vertical element the foundation of which is examined, at the lowest cross-section where a plastic hinge may develop during the earthquake
- M_{Ed} =flexural moment at the lowest cross-section of the element the foundation of which is examined, from analysis for the seismic action that corresponds to the performance level considered
 - M_{Rd} =flexural resistance at the lowest cross-section of the element the foundation of which is examined, calculated using mean values of material properties and the value of the axial force that corresponds to the sense of the seismic action considered
- In case of a common foundation element of multiple vertical elements (foundation beam, raft foundation etc.), the value of Ω may be derived from the element with the largest value of seismic shear force from elastic analysis.

9.3.3 Quasi-elastic design method with use of uniform behaviour factor q

The general safety inequality, see Chapter 4, is evaluated in terms of internal forces with:

- R_d = design value of the resistance in terms of forces, calculated using the representative values of material properties and values of material safety factors γ_m according to § 4.5.3 and

Chapters 7 and 8.

- S_d = internal force component, as follows:
 - a) For ductile failure modes and infill walls:
 - S_d : internal force component from (elastic) analysis with γ_{sd} according to § 4.5.1.
 - b) For brittle behaviour and failure modes:
 - S_d : internal force component derived based on capacity design principles and member equilibrium, according to § 9.3.2(b).

If the Standards applied for the design and construction are dated pre-1995, in order for the values of behaviour factor q' that are defined in Table S 4.4 to be valid, the end sections of columns that frame into a joint must satisfy the condition of non-formation of plastic hinges at column ends:

$$\sum M_{Rc} \geq 1.3 \sum M_{Rb} \quad (S1)$$

In Eq. (S1) M_R denotes the design value of the moment of resistance and subscripts c and b denote columns and beams, respectively, which frame into the joint within a vertical plane. The moments are projections perpendicular to this plane.

The cases of §§ 4.4.2.3(6) and 5.2.3.3(2) of EN 1998-1:2004 are exempted from mandatory application of the rule of non-formation of plastic hinges at column ends.

See related § 9.2.3 for performance level A.

9.3.4 Non-structural elements other than infill walls

Non-structural elements other than infill walls must satisfy the safety verifications for appendages of § 4.3.5 of EN 1998-1:2004 for performance levels B or C.

APPENDIX 9A

SUMMARY OF THE RATIONALE OF THE SAFETY VERIFICATIONS

1) Performance level A, “Immediate occupancy after the earthquake, § 9.2

In general, linear elastic analysis is applied (certainly without capacity design), i.e. for $q \approx m \approx 1.0$ ($\div 1.5$), with verifications in terms of internal forces.

- a) Actions, with γ_{sd} according to § 4.5.1.
- b) Resistances, $R_d (= R_y \approx R_u)$, from mean values of material properties, with R_d and γ_{Rd} according to Chapters 7 and 8 (generally $\gamma_{Rd} \approx 1.0$)

If non-linear analysis is applied with verification in terms of deformations for quasi-ductile elements (only), then for values θ_y , γ_y , $(1/r)_y$ etc., a value of the factor $\gamma_{Rd}=1.0$ is applied.

In effect the two (2) methods are equivalent, and should lead to (practically) the same results.

2) Performance level B or C (“Life protection” or “Collapse prevention”), quasi-elastic analysis, use of q (uniform behaviour factor), § 9.3.3

- a) Actions
 - a.1) Brittle elements: From capacity design, see on **m**, except for the simplifications or exemptions of EC8.
 - a.2) Quasi-ductile elements: With γ_{sd} according to § 4.5.1, certainly without capacity design.
- b) Resistances, using representative values and factors γ_m (Chapter. 4), in terms of forces. Generally with $\gamma_{Rd} \approx 1$.

3) Performance level B or C, elastic analysis, use of m (local ductility factor), § 9.3.2

3.1) Verification in terms of forces, with capacity design for brittle modes of behaviour and failure.

3.2) Brittle elements (verification in terms of forces)

- a) Actions, with force components S_d from capacity design in case of shear forces V_{sd} (i.e. for $\gamma_{Rd} \cdot R_d$) – with mean values of resistances and V_{sd} and γ_{Rd} as follows, for beams, columns, shear walls and foundations (with Ω):
 - for primary elements:
 - for “High” DRL: $\gamma_{Rd} = 1.25$,
 - for “Satisfactory” DRL: $\gamma_{Rd} = 1.40$,
 - for “Tolerable” DRL: $\gamma_{Rd} = 1.50$,
 - $\gamma_{Rd} = 1.0$ for secondary elements.

- b) Resistances, with representative values and γ_m according to § 4.5.3 for primary elements according to Chapters 7 and 8, and mean values of resistances without γ_m for secondary elements.

3.3) Quasi-ductile elements (verifications in terms of forces)

- a) Actions, as $S_G + S_d = S_E/m$, with S_E times γ_{sd} – according to § 4.5.1 and $m = d_d/d_y$, with d_d (and γ_{Rd}) as in inelastic analysis – see § 9.3.1
- b) Resistances, according to Chapters 7 and 8, with mean values without γ_m .

4) Performance level B or C, inelastic analysis, § 9.3.1

4.1) Capacity design is not foreseen.

4.2) Brittle elements (verification in terms of forces)

- a) Actions, with γ_{sd} according to § 4.5.1
- b) Resistances, according to Chapters 7 and 8 with representative values and γ_m according to § 4.5.3 for primary elements, and mean values of resistances without γ_m for secondary elements.

4.3) Quasi-ductile elements (verifications in terms of deformations)

- a) Actions, as above (§ 4.2.a)
- b) Resistances, with R_d according to Chapters 7 and 8, with mean (frequent) values and γ_{Rd} :

b.1) Perf. Level B:

- Primary structural elements
- Secondary structural elements
(no verification required for horizontal secondary elements)
- Infill walls

$$R_d = 0.5 (d_y + d_u) : \gamma_{Rd}$$

$$R_d = d_u : \gamma_{Rd}$$

$$R_d = d_u : \gamma_{Rd}$$

γ_{Rd} values are selected so that the values of R_d correspond to mean values minus one standard deviation.

It is recommended:

For primary and secondary elements, in terms of θ_u :	$\gamma_{Rd} = 1.50$
For primary and secondary elements, in terms of θ_u^{pl} :	$\gamma_{Rd} = 1.80$
For infill walls, in terms of γ or ε :	$\gamma_{Rd} = 1.30$ for unreinforced or 1.2 for reinforced.

b.1) Perf. Level C:

• Primary structural elements	$R_d = 0.5 (d_y + d_u) : \gamma_{Rd}$
• Secondary structural elements	$R_d = d_u : \gamma_{Rd}$
• Infill walls	$R_d = d_u : \gamma_{Rd}$

(no verification required for horizontal secondary elements)

It is recommended:

For primary structural elements:	γ_{Rd} as above (§ 4.3.b1)
For secondary structural elements:	$\gamma_{Rd} = 1.00$
For infill walls, in terms of γ :	$\gamma_{Rd} = 1.00$.

5) Increase of values of q or m

For buildings where the influence of higher modes is important, inelastic static analysis may be applied combined with elastic dynamic analysis, see § 5.7.2.b and § 9.1.3.c, so all verifications are performed using both methods and an increase by 25% of the values of the parameters involved in the verification criteria is allowed.

That is, if the method of the uniform behaviour factor is applied, the increase of q by 25% is allowed, while if the method of local factors (for individual structural elements) is applied, the values of m may be increased by 25%.

6) Non-structural elements, other than infill walls, performance level A (§ 9.2.3) or B or C (§ 9.3.4)

They are checked as “appendages” according to 4.3.5 of EN 1998-1:2004.

CHAPTER 10

REQUIRED CONTENTS OF THE DESIGN

10.1 ASSESSMENT PHASE

10.1.1 Data collection and information Report

The Report must include all the available data, general

information and background on the following items:

- On the available structural design
 - Buildings constructed without structural design
 - Buildings constructed according to structural design which is not available
 - Buildings constructed according to structural design which is available
 - Buildings for which the (available) structural design has not been applied
- On the building permit
 - Buildings that have been constructed with a building permit
 - Buildings that have been constructed without a building permit
- On damage (or deterioration)
 - Buildings without damage
 - Buildings with damage
- On any previous interventions, additions etc.
 - Buildings with a history of previous additions, interventions or reports concerning required interventions
 - Buildings without interventions, additions, changes etc.

10.1.2 Survey-documentation Report

The survey-documentation Report should list all actions and their results towards surveying and documenting the structure as set out in Chapter 3 (measurements, photographs, taking of samples, laboratory or in-situ tests and their results, etc.)

For the presentation of damage or wear, a Report should be drafted, containing photographs and description of each case of damage or wear.

10.1.3 General drawings of the survey of the structure and presentation of damage

Drawings of the structure shall be drafted, which must agree as much as possible to what has been applied during its construction. These drawings should present in the best detail possible any damage or wear (see Chapter 3).

If the corresponding drawings of the building permit are not available (or significant deviations have been made), architectural drawings of the building should be drafted which should contain the infill walls with any damage or wear they may have.

10.1.4 Structural capacity assessment report

On the basis of the survey, the results of any in-situ laboratory tests (see Chapter 3) and any required computational checks, a Report shall be drafted, detailing the assumptions for the assessment of structural capacity, the performance level according to Chapter 2, the behaviour of the structure over time and the assessment conclusions.

The Report on the assessment of structural capacity should contain references and take into account the Data Reliability Level, as well as the foundation soil.

It should also contain the information specified in § 10.2.1 a, b, c, d.

10.1.5 Decision making – proposal of interventions report

Based on the above assessment conclusions, decisions are

made and a report with proposals for interventions is drafted. The proposed interventions should take into account the desired performance level, the feasibility of the interventions and their cost-effectiveness in relation to the total cost of demolition and reconstruction of the structure.

10.1.6 Structural calculations, analysis and verification reports

All drawings and technical reports mentioned in the preceding paragraphs must be accompanied and supported by structural calculations, analyses and verifications reports. These reports should contain assessment assumptions, loads, material properties, computational models (with special reference and marking of members which are considered secondary) and a brief description of the software used.

10.2 REDESIGN PHASE

10.2.1 Interventions application report

The report should be linked to the drawings through appropriate references.

This report should contain:

- A list with numbering and descriptions of the drawings and reports that accompany the study
- Description of the existing structure and its infills.
- Description of damage and wear.
- Design assumptions and materials for the interventions, as well as applied Standards.
- Brief description of the interventions
- Description of safety measures to be taken during the

Interventions' drawings shall indicate the structure (without the reinforcements) and infills (if taken into account), and also the intervention elements with dimensions, indication of the type of intervention and references to detail drawings.

In the same drawings, or in another series of drawings to which a reference shall be made, any structural or non-structural elements which may need to be demolished in order to perform the interventions shall be indicated. This series of demolition drawings shall contain either an outline of the safety measures and temporary supports or retaining, or a relevant reference to the interventions application report.

The foundation of new elements, combined with the existing ones shall be clearly indicated in the general drawings, which shall also contain the assumptions of the design and the materials to be applied during the interventions, together with the relevant specifications.

Indicatively, the reinforcement of the interventions must be clearly

works.

- Description of preliminary work to be done.
- Detailed description of the components of the interventions and their connection to the existing structure
- Any other information which is necessary for the implementation of interventions.

10.2.2 General interventions description drawings

All proposed interventions should be described in drawings compatible with the technical reports.

10.2.3 Detail drawings

All proposed interventions shall be covered by drawings in a

shown, and especially the anchoring of new reinforcements in existing structural elements, the means of connection of the interfaces of old and new concrete (dowels, anchors, epoxy adhesives etc.).

The report may make reference to existing Standards, instructions from suppliers or manufacturers, competent authorities' approval certificates etc., as well as quality control requirements contained in regulatory specifications.

To this end, the Recommendations for Technical Specifications for Interventions (OASP, 2006) are applied.

This report shall contain, among other things, details relevant to:

- Periodic inspection
- Periodic durability checks of the intervention construction.

Periodic checks especially for the case of buildings of high importance (e.g. schools, hospitals etc.).

proper scale that shall describe in detail all elements of the proposed construction.

All detail drawings must contain a correlation reference to the corresponding general drawings.

If added structural elements are required, their connection with the existing structure must be shown in detail drawings.

10.2.4 Standards for materials, workmanship and quality control requirements

A special section of the interventions application report (or a separate report) shall contain the standards of proposed materials as well as the technical specifications of the project. The same report shall contain, in detail, the quality control requirements during the works, either in-situ or at a certified laboratory.

10.2.5 Maintenance measures report

A special section of the interventions application report (or a separate report) shall contain provisions concerning the required maintenance measures after the completion of the intervention works, and for all the duration of the foreseen technical lifetime of the structure.

This Report shall be delivered to the owner of the structure during the delivery of the project.

10.2.6 Structural calculations, analysis and verifications reports

All drawings and technical reports mentioned in the previous

paragraphs must be accompanied and documented by calculations reports. These reports shall include the redesign assumptions, loads, material characteristics, computational models for the analysis (with special reference / indication of secondary members), as well as a brief description of the software used.

CHAPTER 11

CONSTRUCTION – QUALITY ASSURANCE - MAINTENANCE

11.1 CONSTRUCTION

11.1.1 Technical knowledge and experience of construction personnel

11.1.1.1 Required qualifications of Contractor

The Contractor must also possess the qualifications required by the statutory procedures of issuing experience certificates for similar projects.

Due to the special nature of the construction, the Contractor must hold both a Civil Engineer Diploma and a Contractor License.

Required qualifications of technicians

Operators of special machinery (i.e. for shotcrete, epoxy adhesives etc.) and special craftsmen employed by the Contractor must possess qualifications proven by experience certificates.

11.1.1.2 Obligations and responsibilities of Contractor

The general obligations and responsibilities of the

See related PD 305, 29.8.96, “Minimum safety and health requirements at temporary or mobile construction sites in compliance with Directive 92/57/EEC”.

The additional safety measures foreseen in the Recommendations for Technical Specifications for Interventions, OASP, 2006, also apply.

A competent Public Authority issues the provisions concerning the approval of commercial distribution of these materials.

Contractor arise from existing legislation for public and private projects.

In particular, the obligations and responsibilities of the Contractor include:

a) Physical presence during the works

During the construction, either the Contractor himself or his authorised representative of equal qualifications must be always present in order to be able, in the case of unforeseen circumstances, to alter the schedule of works or take additional safety measures.

b) Safety measures

From the beginning of and throughout the construction period of the project, the Contractor shall, at his own expense, take and maintain all the necessary safety and protection measures for works and personnel in accordance with applicable provisions.

c) Application of specifications

The contractor is generally responsible for the proper execution of the works and the use of materials, as well as monitoring of materials, as foreseen specifically by the technical specifications of the design.

The supplier-manufacturer of these materials shall not be exempted of the responsibility for the quality of these materials.

d) Log keeping

Care of the Contractor the following logs shall be kept:

- Project log
 - Safety measures log
- e) *As-built drawings of the interventions*
After completion of the works, the Contractor must necessarily submit to the Owner of the project (and also to the Public Authority) exact as-built construction drawings for the repairs – strengthening.

11.2 QUALITY ASSURANCE

11.2.1 General

The quality of materials and works of the intervention must be assured. To this end, a set of activities and procedures must be followed, including:

- The Schedule of Procedures and Checks
- Supervision, and
- Quality Control

11.2.2 Schedule of Procedures and Checks

a) *General*

A full schedule of procedures and controls must be drawn up and followed, in order to ensure that the quality of materials and workmanship shall meet all the design

requirements at all stages of the project, from tendering until completion and acceptance, so that the following are guaranteed:

- the technical knowledge and experience of involved personnel
- the safety measures
- the quality of materials
- the protection of personnel health
- compliance with all the standards and specifications set by the design.

b) Contents of the Schedule

i) During tender phase

Each bidder along with the tender must submit a complete schedule of procedures and controls in order to ensure the quality of materials and operations, as required by the tender call and relevant specifications. This schedule shall cover the following topics:

- Examination of prerequisites on the technical knowledge and experience of staff.
- Review of safety conditions during the execution.
- Review of material certificates and possibly acceptance tests.
- Health protection from potentially harmful materials or equipment on site.
- Ensuring the presence of qualified Engineers throughout the course of

construction.

ii) Before commencement of works

- The Contractor shall submit for approval any required additional technical specifications and certificates of all materials to be used.
- The Contractor shall also submit a list of staff he will be employing to execute the special operations involved in the interventions, where the experience of each individual involved should be clearly indicated.

iii) During the construction phase

- The Contractor shall submit for approval to the supervision a detailed description of the tests to be performed in accordance with quality control requirements specified in the relevant document of the intervention design.
- Throughout the course of construction, the supervising Engineer as well as the Contractor must control the works diligently. More specifically, for the control procedures the provisions of § 11.2.4 apply.

11.2.3 Supervision

11.2.3.1 Scope

The key tasks of the supervision include:

- Monitoring the implementation of security measures.
- Control of the consistency of construction drawings with the actual situation.
- Audit of experience and specialization of crews in similar constructions.
- Compliance with the technical specifications.

Supervision aims at controlling the accurate execution of the terms of the contract by the Contractor, the adherence to the design and quality assurance standards of materials and operations of the intervention.

11.2.3.2 Technical knowledge and experience of supervising personnel

The supervisor should hold a Civil Engineering diploma and have at least five years experience in similar projects.

The participation of the designer Engineer to the supervision of the project is recommended.

11.2.3.3 Actions required of the Supervisor

a) Before commencement of construction

The supervising Engineer in cooperation with the Contractor must:

- To scrutinize the contents of the design that concern the works he shall supervise. To study in detail the proposed phases of work, the construction details to be implemented, the assumptions, reports, drawings and technical specifications of

the design.

- To inspect the location where the works will be performed, to check the existing safety measures and to suggest improvements or changes if needed.
- To check the safety measures proposed by the Contractor.
- To check the certificates of the materials to be used.
- To check the lists of specialised personnel.
- To check the recommendations of the Contractor on the work phases and the project schedule.
- Finally, to organize the works so that they can be performed safely and workmanlike, according to the design and within a reasonable time period.

b) During the construction

The supervisor Engineer in cooperation with the Contractor must monitor the faithful implementation of the design and the rules of quality assurance.

11.2.4 Quality Control

11.2.4.1 General-Definitions

This paragraph does not relate to a contractual or legal perspective of acceptance of a project, nor the consequences of unacceptable

Quality Control includes a combination of actions and decisions to ensure that the requirements of

performance of part of the project (penalty clause, rejection) or the apportionment of responsibilities.

technical standards are met, as well as checks that ensure the satisfaction of the above requirements. Specifically quality control involves:

- Production Checks, and
- Checks on the Delivery of the Project

11.2.4.2 *Production Checks*

a) *Preliminary Checks*

i) *Γενικά General*

The aim of the preliminary checks done before the start of production procedures is to check the ability to construct the project according to the design using the available materials, equipment and the foreseen / available construction methods. The preliminary checks concern the reliability of the design, the reliability of materials and their ingredients and the reliability of the methods and means of construction.

ii) *Reliability of the design*

The design should be checked before implementation as to its reliability and the compatibility of drawings with the design documents.

The set of drawings and documents must be complete.

The design should cover all phases of construction and use of the project.

The person in charge of construction may

The Public Authority sets the terms for checking the design.

The reliability of the design concerns mainly:

- The loads, calculation methods and analytical models,
- The construction tolerances to be respected,
- The calculations, which must be accurate, and the results of which must be properly conveyed to the drawings and technical documents.

The requirements relate to the strength, composition, consistency, water tightness, resistance to frost, corrosion etc.

The materials and ingredients are required to follow on Standards or Technical Approvals.

Visual inspection is always necessary.

The documents that certify the compliance of the material with specifications can be either a letter, voucher or marking on the packaging or the product itself.

not, in any way, modify the design on his own initiative.

iii) Reliability of choice of materials and ingredients

The quality and compatibility of materials and ingredients of concrete, mortar and other materials should be checked by preliminary tests, as foreseen by the Technical Specifications.

iv) Reliability of the methods and means of construction

The equipment to be used and the proposed construction methods should be precisely defined and checked, and possibly be tested before construction begins, in the opinion of the supervising engineer.

b) Checks of materials and works during construction

i) Material tests

- Tests during delivery on the site
It is assumed that the checks of the materials and ingredients are done by the manufacturer at the factory.
At the site it should be checked upon arrival that all the materials and ingredients delivered match the order. The inspection will involve their identification and compliance with the specifications of the tender approval.

For example, storage conditions should not cause unacceptable pollution of aggregates, corrosion of steel, expiration of materials etc.

All materials used must be accompanied by certificates of compliance, which show explicitly that the quality and method of production of the material is in accordance with the Standard or Technical Approval.

- Checks before use
Before any use of materials and ingredients in the project, it should be checked that they have not been subjected to damage or wear since their reception at the construction site or at the factory that make them unfit for use.
Potentially, their mutual compatibility shall be checked.

ii) *Checks during the execution of works*

Checks during the execution of the works mainly concern:

- Before the execution of a given task, the prerequisites for commencement of the task are checked (e.g. surface preparation, preparation of materials, etc.).
- During the execution of the work, the application of the rules of good workmanship for the task are checked, as described in the specifications of works, aimed among other things to the early identification of defects,

allowing immediate corrective action in order to restore the defects before the completion of the work.

The check after the work includes testing for acceptance of the work according to the relevant provisions of the technical specification for works.

11.2.4.3 Checks for the Acceptance of the Project

a) General

The checks for the acceptance of the Project aim at deciding on acceptance or rejection of the construction.

These checks concern the materials and their ingredients, as well as the construction as a whole.

i) Materials and ingredients

The check concerns the validity of checks made before and during production, in accordance with the previous paragraph.

ii) Check of the finished construction

The check consists of a visual inspection of the construction. It is checked that all works foreseen by the design have been executed in the intended positions and dimensions.

b) Project data

After the delivery – acceptance of the project, all documents, drawings and other data relating to the construction of the project as actually

Depending on the type and intended use of the structure, additional checks may be required.

Also, experimental testing of the structure may be required.

executed are delivered to the Owner of the project.

11.3 MAINTENANCE

11.3.1 General

For the information of the end-users of a project it may be appropriate to place, at appropriate locations of buildings or other structures, signs which indicate the maximum allowable loads (or other actions).

The attention of end-users of a project must be drawn to situations that may lead to unacceptable risks during the use (i.e. change of use of a residential space).

Structures must be maintained at the responsibility of their owners to ensure the preservation, over time, of the strength and functionality for which they were designed.

11.3.2 Periodic inspections

In common cases (moderately corrosive environment and average use), appropriate intervals between inspections are:

- For residential buildings 10 years
- For small or large industrial buildings 5 to 10 years.

The high sensitivity of interfaces created during the repairs or strengthening as well as the use of unconventional materials require special attention as to the conditions of the intervention works during their life cycle. So periodic inspections at regular intervals are imperative.

The inspections aim at detecting the possible appearance of wear and damage during the life span of the project, especially in positions of repair – strengthening.

Projects of great importance in special environments should be inspected more regularly, and if necessary, using special instruments that have been embedded during the repair – strengthening works.

11.3.3 Evidence of damage

Changes in colour, splitting – spalling of concrete, leaks, rust, cracks or excessive deformations may be signs of serious damage.

If serious damage is suspected, the assistance of an expert is necessary in order to analyze the cause, assess the damage and provide guidance for interventions, if needed.